

125SVX02N150PT04QBE | Configuration Summary

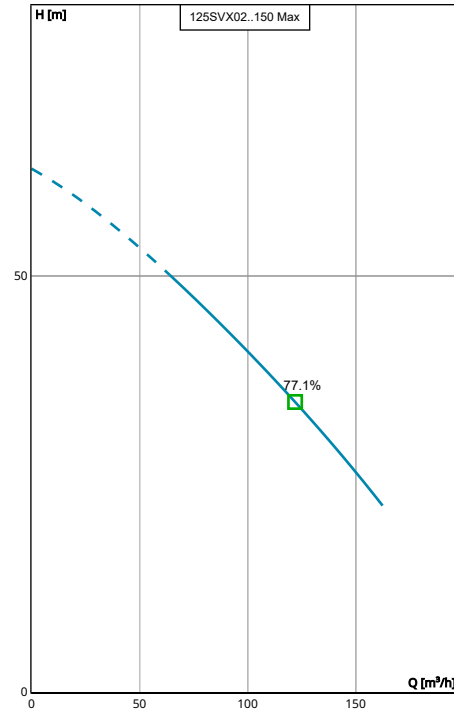

Take the efficiency and low lifetime costs of e-SV multistage pumps to new levels with hydrovar® X – first-class pump management that optimises connectivity, sustainability and performance. Hydrovar® X brings the best energy efficiency performances with its frequency converter coupled with the ultimate synchronous motor, manufactured by Xylem integrating decades of expertise and know-how in pumping solutions.



Performance according to ISO 9906:2012

PUMP

Installation	Pump Size
Complete Pump	125SV
Hydrovar Name	
hydrovar X+	

MATERIALS

Pump Body Material	Impeller Material
Stainless Steel (AISI 316)	Stainless Steel (AISI 316)

SEAL

Type of Seal	Rotating Face
Mechanical Seals	Silicon Carbide
Name	Stationary Face
Q1BEGG	Resin Impregnated Carbon
	Elastomers
	EPDM
	Springs
	AISI 316
	Metal Components
	AISI 316
	Min Temperature
	-30.0 °C
	Max Temperature
	120.0 °C

STANDARD OPTIONS

Special Configuration
Please Select

MOTOR

Poles	Power
2	15 kW
	Phase (~)
	3
	Voltage
	380-480 V

FLANGE

Flange
[N] = Round Flanges (AISI 316)

VFD

Phase	Supply Voltage
3	380-480 V

125SVX02N150PT04QBE | Product Details



05104_A_DS

Construction Materials

Pump body (1) Stainless Steel / ASTM CF8M	Shaft (5) Duplex stainless steel	Upper head, Seal housing (9-9A) Stainless Steel / ASTM CF8M	Shaft sleeve and bushing (13) Tungsten carbide
Lower support (1A) Stainless Steel / ASTM CF8M	Adapter (6) Cast Iron / ASTM Class 25	Mechanical seal (10) See Seal section	Bushing for diffuser (14) Carbon
Impeller, Diffuser (2-3) Stainless Steel / ASTM CF8M	Wear ring (7) Technopolymer PPS	Elastomers (11) See Seal section	Fill / Drain / Air plugs (15) Stainless steel / AISI 316
Outer sleeve (4) Stainless steel / AISI 316L	Coupling (8) Cast Iron / ASTM Class 25	Coupling protection (12) Stainless steel / AISI 304	Tie rods (16) Stainless steel / AISI 431
Adapter ring (17) Stainless Steel / ASTM CF8M			

Motor

Motor Name EXM160B5SV/4.150D	Rated power 15 kW	Enclosure IP 55	ICL F
Phase 3	IE Class IE5	Frame Size 160	Standard IEC
Voltage 380-480 V	Motor Vendor Xylem		
Speed 3600.0 rpm			
Rated Current 27.5 A			

125SVX02N150PT04QBE | Hydraulic Data & Performance Curve

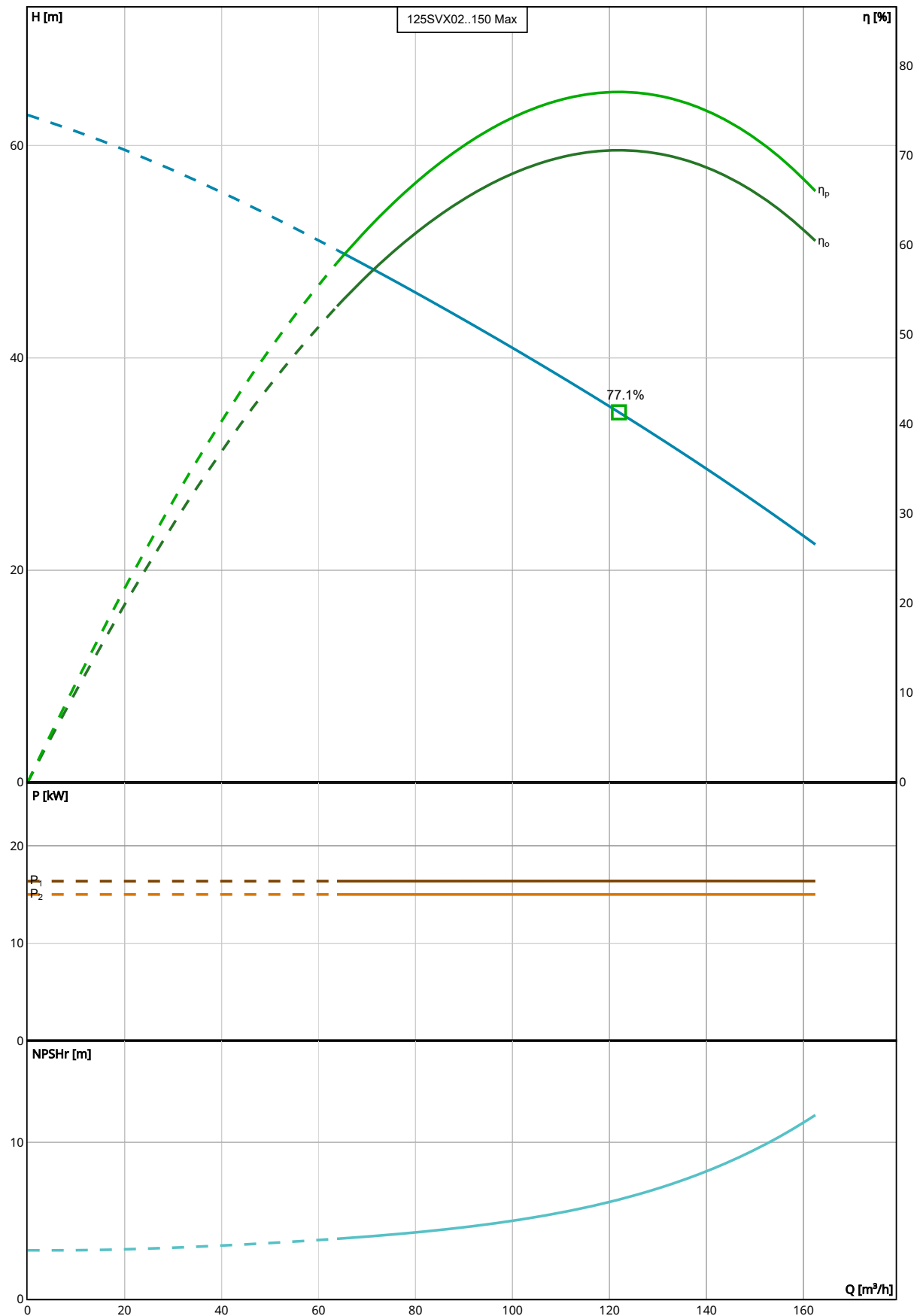

Performance according to ISO 9906:2012

Selection

Series	Standby Pumps
e-SV hydrovar X	No Standby Pump
Name	
125SVX02..150	
Stages	
2	
Frequency	
50 Hz	
Acceptance Grade	
Manufacturer's Standard	
System Type	
Single Pump	
Operating Pumps	
1	

Fluid and Operating Conditions

Fluid Type	Density
Water	1,000 kg/m ³
Fluid Temperature	Dynamic Viscosity
4 °C	0.002 Pa·s
Specific Gravity	Fluid Vapor Pressure
1	8.14 mbar
	Atmospheric Pressure
	1,013.53 mbar
	Elevation
	0 m
	Ambient Temperature
	20 °C
	NPSH Available
	10.27 m
	Submergence
	0 m

Design Curve

Rated Speed	BEP
3,600 RPM	77.07 %
Min Flow	BEP Flow
63.8 m ³ /h	121.94 m ³ /h
Max Flow	BEP Head
162.44 m ³ /h	34.86 m
H@QMin	Max Operating Pressure
50.15 m	6,157.8 mbar
H@QMax	Max P2
22.42 m	15 kW

125SVX02N150PT04QBE | Dimensional Data & Drawing

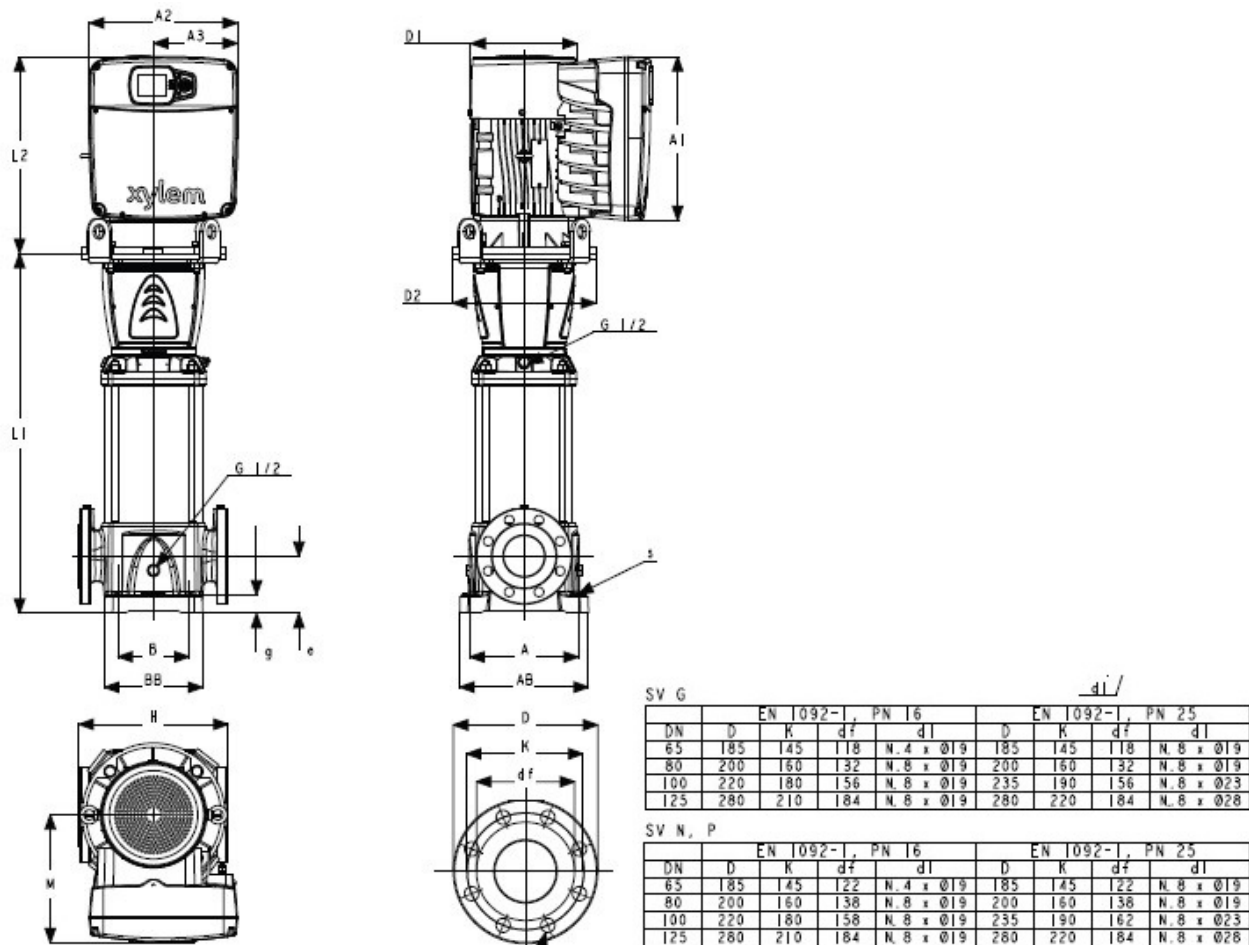

Drawing is preliminary and is subject to change.

Dimensions

A	D2	L1	Total Weight
380 mm	350 mm	878 mm	203 kg
AB	e	DN	L2
450 mm	160 mm	125 mm	480 mm
B	g	S.	D1
275 mm	45 mm	4xØ19	260 mm
BB	H	Weight (Pump)	A1
330 mm	480 mm	131 kg	400 mm
A2			
362 mm			
A3			
205 mm			
M			
312 mm			