

## 92SVX02N150PT04QBE | Configuration Summary

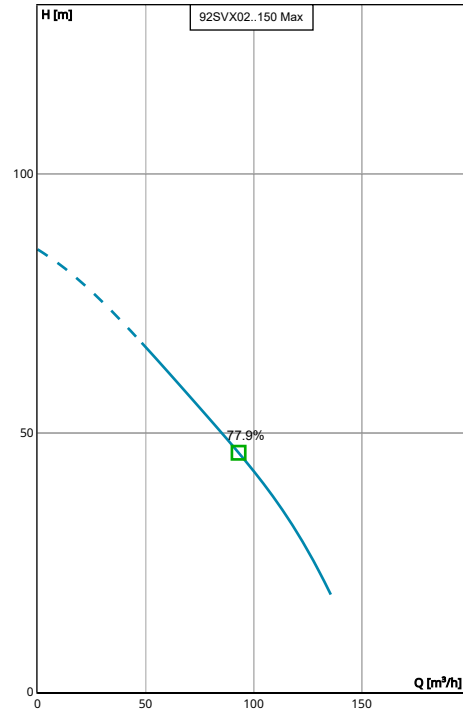

Take the efficiency and low lifetime costs of e-SV multistage pumps to new levels with hydrovar® X – first-class pump management that optimises connectivity, sustainability and performance. Hydrovar® X brings the best energy efficiency performances with its frequency converter coupled with the ultimate synchronous motor, manufactured by Xylem integrating decades of expertise and know-how in pumping solutions.



Performance according to ISO 9906:2012

### PUMP

<b>Installation</b>	<b>Pump Size</b>
Complete Pump	92SV
<b>Hydrovar Name</b>	
hydrovar X+	

### MATERIALS

<b>Pump Body Material</b>	<b>Impeller Material</b>
Stainless Steel	Stainless Steel (AISI 316L)

### SEAL

<b>Type of Seal</b>	<b>Rotating Face</b>
Mechanical Seals	Silicon Carbide
<b>Name</b>	<b>Stationary Face</b>
Q1BEGG	Resin Impregnated Carbon
	<b>Elastomers</b>
	EPDM
	<b>Springs</b>
	AISI 316
	<b>Metal Components</b>
	AISI 316
	<b>Min Temperature</b>
	-30.0 °C
	<b>Max Temperature</b>
	120.0 °C

### STANDARD OPTIONS

<b>Special Configuration</b>
Please Select

### MOTOR

<b>Poles</b>	<b>Power</b>
2	15 kW
	<b>Phase (~)</b>
	3
	<b>Voltage</b>
	380-480 V

### FLANGE

<b>Flange</b>
[N] = Round Flanges (AISI 316)

### VFD

<b>Phase</b>	<b>Supply Voltage</b>
3	380-480 V

**92SVX02N150PT04QBE** | Product Details



05104\_A\_DS

**Construction Materials**

<b>Pump body (1)</b> Stainless Steel / ASTM CF8M	<b>Outer sleeve (4)</b> Stainless steel / AISI 316L	<b>Coupling (8)</b> Cast Iron / ASTM Class 25	<b>Elastomers (11)</b> See Seal section
<b>Lower support (1A)</b> Stainless Steel / ASTM CF8M	<b>Shaft (5)</b> Duplex stainless steel	<b>Upper head (9)</b> Stainless Steel / ASTM CF8M	<b>Coupling protection (12)</b> Stainless steel / AISI 304
<b>Impeller (2)</b> Stainless steel / AISI 316L	<b>Adapter (6)</b> Cast Iron / ASTM Class 25	<b>Seal housing (9A)</b> Stainless Steel / ASTM CF8M	<b>Shaft sleeve and bushing (13)</b> Tungsten carbide
<b>Diffuser (3)</b> Stainless steel / AISI 316L	<b>Wear ring (7)</b> Technopolymer PPS	<b>Mechanical seal (10)</b> See Seal section	<b>Bushing for diffuser (14)</b> Carbon
<b>Fill / Drain plugs (15)</b> Stainless steel / AISI 316			
<b>Tie rods (16)</b> Stainless steel / AISI 431			

**Motor**

<b>Motor Name</b> EXM160B5SV/4.150D	<b>Rated power</b> 15 kW	<b>Enclosure</b> IP 55	<b>ICL</b> F
<b>Phase</b> 3	<b>IE Class</b> IE5	<b>Frame Size</b> 160	<b>Standard</b> IEC
<b>Voltage</b> 380-480 V	<b>Motor Vendor</b> Xylem		
<b>Speed</b> 3600.0 rpm			
<b>Rated Current</b> 27.5 A			

### 92SVX02N150PT04QBE | Hydraulic Data & Performance Curve

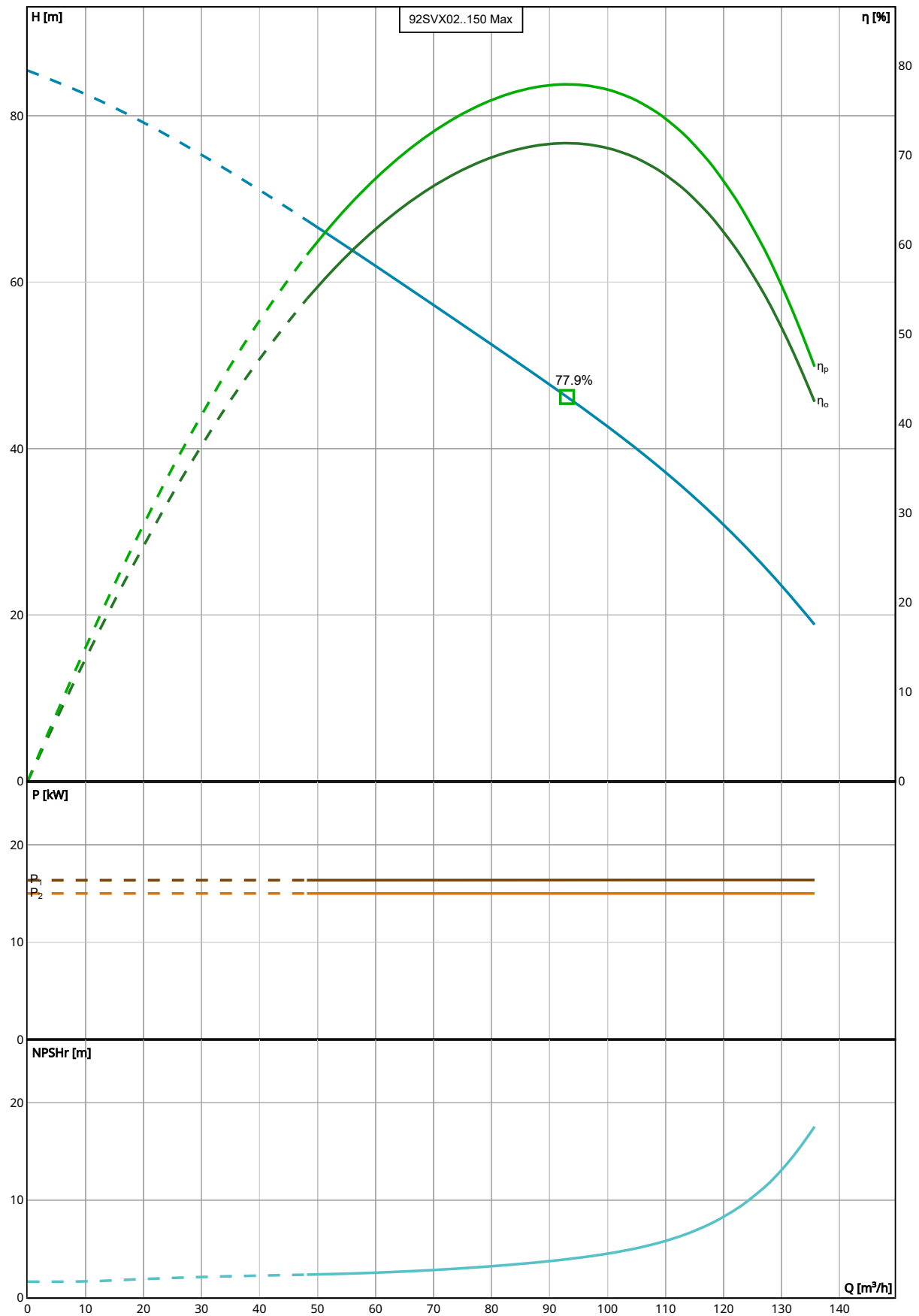

Performance according to ISO 9906:2012

**Selection**

Series	Standby Pumps
e-SV hydrovar X	No Standby Pump
Name	
92SVX02..150	
Stages	
2	
Frequency	
50 Hz	
Acceptance Grade	
Manufacturer's Standard	
System Type	
Single Pump	
Operating Pumps	
1	

**Fluid and Operating Conditions**

Fluid Type	Density
Water	1,000 kg/m <sup>3</sup>
Fluid Temperature	Dynamic Viscosity
4 °C	0.002 Pa·s
Specific Gravity	Fluid Vapor Pressure
1	8.14 mbar
	Atmospheric Pressure
	1,013.53 mbar
	Elevation
	0 m
	Ambient Temperature
	20 °C
	NPSH Available
	10.27 m
	Submergence
	0 m

**Design Curve**

Rated Speed	BEP
3,600 RPM	77.91 %
Min Flow	BEP Flow
48.16 m <sup>3</sup> /h	93.02 m <sup>3</sup> /h
Max Flow	BEP Head
135.68 m <sup>3</sup> /h	46.21 m
H@QMin	Max Operating Pressure
67.42 m	8,366.16 mbar
H@QMax	Max P2
18.85 m	15 kW

**92SVX02N150PT04QBE** | Dimensional Data & Drawing

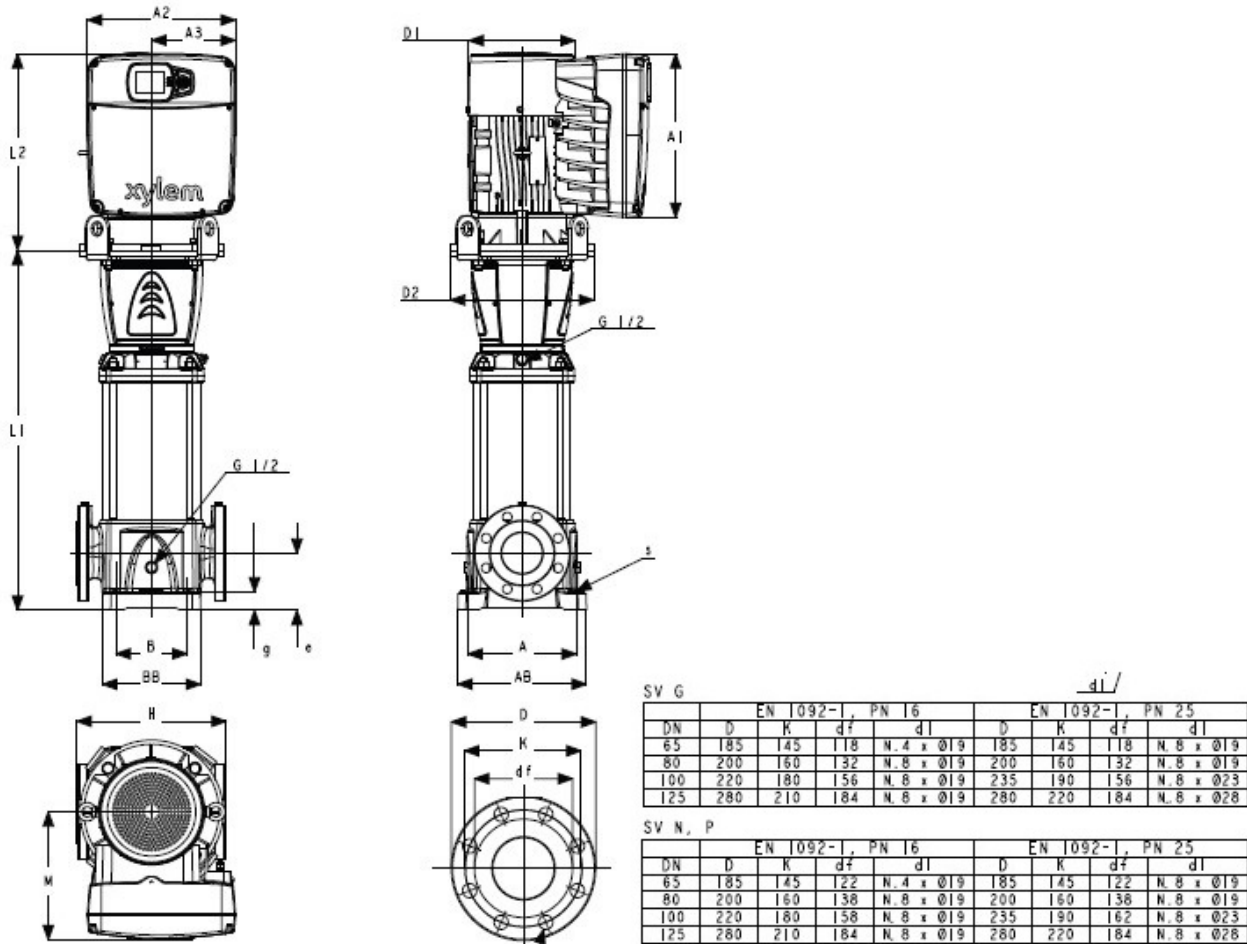

Drawing is preliminary and is subject to change.

**Dimensions**

<b>A</b> 265 mm	<b>D2</b> 350 mm	<b>L1</b> 699 mm	<b>Total Weight</b> 152 kg
<b>AB</b> 315 mm	<b>e</b> 140 mm	<b>DN</b> 100 mm	<b>L2</b> 480 mm
<b>B</b> 190 mm	<b>g</b> 45 mm	<b>S.</b> 4xØ15	<b>D1</b> 260 mm
<b>BB</b> 240 mm	<b>H</b> 365 mm	<b>Weight (Pump)</b> 80 kg	<b>A1</b> 400 mm
<b>A2</b> 362 mm			
<b>A3</b> 205 mm			
<b>M</b> 312 mm			