

33SVX03N110PT04QBE | Configuration Summary

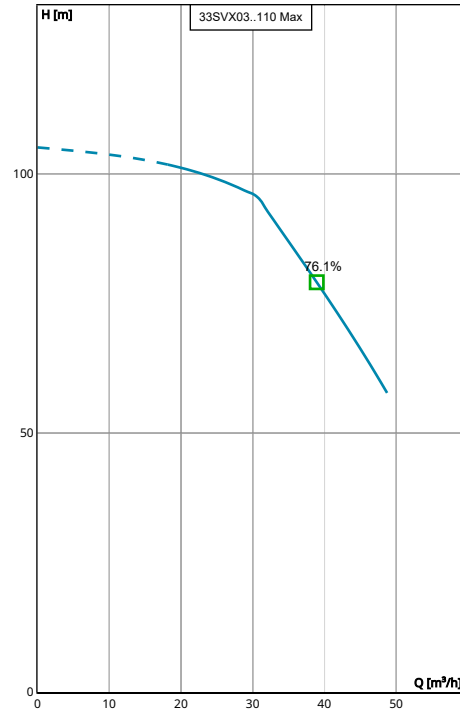

Take the efficiency and low lifetime costs of e-SV multistage pumps to new levels with hydrovar® X – first-class pump management that optimises connectivity, sustainability and performance. Hydrovar® X brings the best energy efficiency performances with its frequency converter coupled with the ultimate synchronous motor, manufactured by Xylem integrating decades of expertise and know-how in pumping solutions.



Performance according to ISO 9906:2012

PUMP

Installation	Pump Size
Complete Pump	33SV
Hydrovar Name	
hydrovar X+	

MATERIALS

Pump Body Material	Impeller Material
Stainless Steel	Stainless Steel (AISI 316L)

SEAL

Type of Seal	Rotating Face
Mechanical Seals	Silicon Carbide
Name	Stationary Face
Q1BEGG	Resin Impregnated Carbon
	Elastomers
	EPDM
	Springs
	AISI 316
	Metal Components
	AISI 316
	Min Temperature
	-30.0 °C
	Max Temperature
	120.0 °C

STANDARD OPTIONS

Special Configuration
Please Select

MOTOR

Poles	Power
2	11 kW
	Phase (~)
	3
	Voltage
	380-480 V

FLANGE

Flange
[N] = Round Flanges (AISI 316)

VFD

Phase	Supply Voltage
3	380-480 V

33SVX03N110PT04QBE | Product Details



05104_A_DS

Construction Materials

Pump body (1) Stainless Steel / ASTM CF8M	Outer sleeve (4) Stainless steel / AISI 316L	Coupling (8) Cast Iron / ASTM Class 25	Elastomers (11) See Seal section
Lower support (1A) Stainless Steel / ASTM CF8M	Shaft (5) Duplex stainless steel	Upper head (9) Stainless Steel / ASTM CF8M	Coupling protection (12) Stainless steel / AISI 304
Impeller (2) Stainless steel / AISI 316L	Adapter (6) Cast Iron / ASTM Class 25	Seal housing (9A) Stainless Steel / ASTM CF8M	Shaft sleeve and bushing (13) Tungsten carbide
Diffuser (3) Stainless steel / AISI 316L	Wear ring (7) Technopolymer PPS	Mechanical seal (10) See Seal section	Bushing for diffuser (14) Carbon
Fill / Drain plugs (15) Stainless steel / AISI 316			
Tie rods (16) Stainless steel / AISI 431			

Motor

Motor Name EXM160B5SV/4.110C	Rated power 11 kW	Enclosure IP 55	ICL F
Phase 3	IE Class IE5	Frame Size 160	Standard IEC
Voltage 380-480 V	Motor Vendor Xylem		
Speed 3600.0 rpm			
Rated Current 19.8 A			

33SVX03N110PT04QBE | Hydraulic Data & Performance Curve

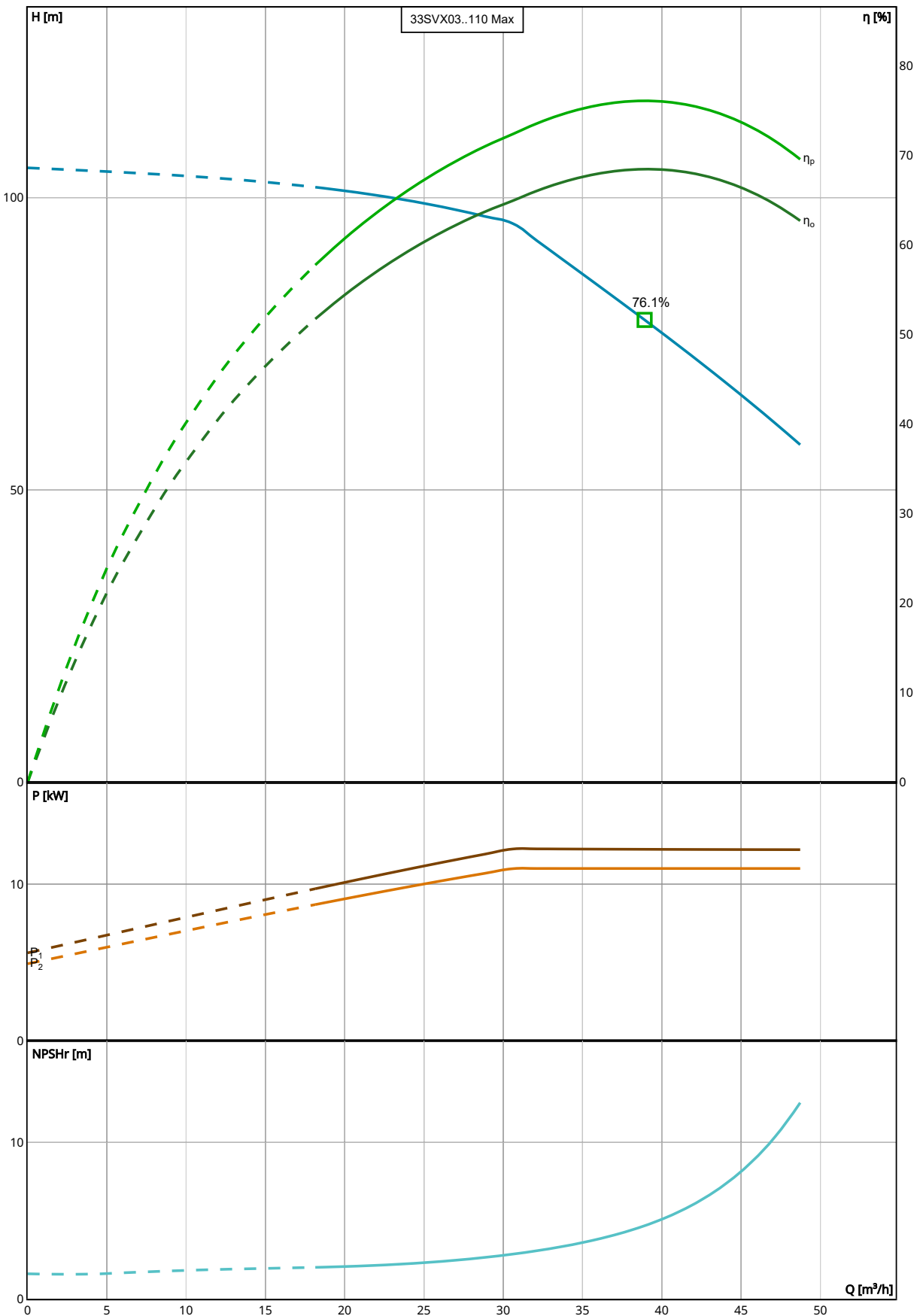

Performance according to ISO 9906:2012

Selection

Series	Standby Pumps
e-SV hydrovar X	No Standby Pump
Name	
33SVX03..110	
Stages	
3	
Frequency	
50 Hz	
Acceptance Grade	
Manufacturer's Standard	
System Type	
Single Pump	
Operating Pumps	
1	

Fluid and Operating Conditions

Fluid Type	Density
Water	1,000 kg/m ³
Fluid Temperature	Dynamic Viscosity
4 °C	0.002 Pa·s
Specific Gravity	Fluid Vapor Pressure
1	8.14 mbar
	Atmospheric Pressure
	1,013.53 mbar
	Elevation
	0 m
	Ambient Temperature
	20 °C
	NPSH Available
	10.27 m
	Submergence
	0 m

Design Curve

Rated Speed	BEP
3,600 RPM	76.08 %
Min Flow	BEP Flow
18.14 m ³ /h	38.92 m ³ /h
Max Flow	BEP Head
48.73 m ³ /h	79.09 m
H@QMin	Max Operating Pressure
101.78 m	10,291.3 mbar
H@QMax	Max P2
57.75 m	11.01 kW

33SVX03N110PT04QBE | Dimensional Data & Drawing

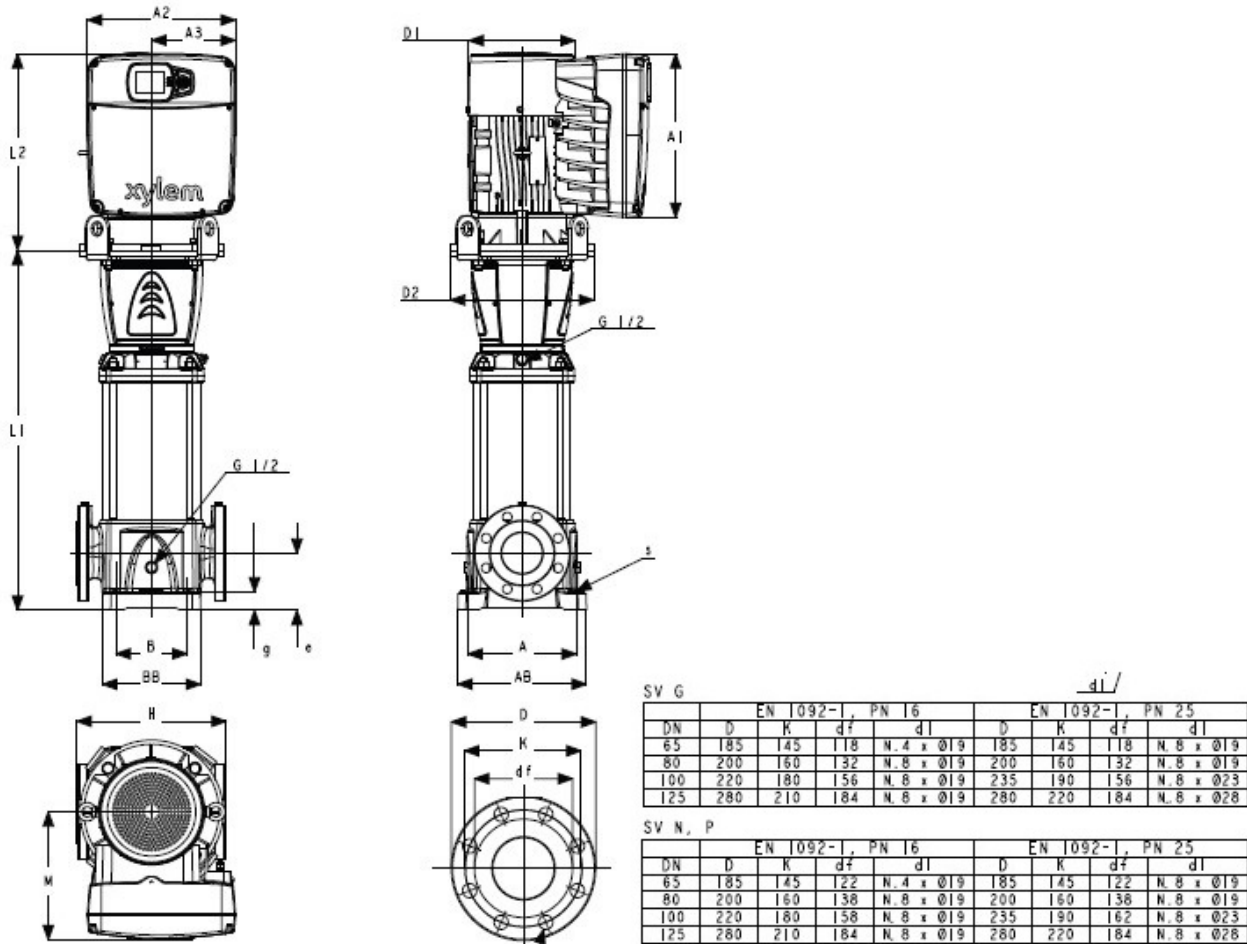

Drawing is preliminary and is subject to change.

Dimensions

A 240 mm	D2 350 mm	L1 694 mm	Total Weight 121 kg
AB 290 mm	e 105 mm	DN 65 mm	L2 404 mm
B 170 mm	g 30 mm	S. 4xØ15	D1 220 mm
BB 220 mm	H 320 mm	Weight (Pump) 69 kg	A1 329 mm
A2 302 mm			
A3 175 mm			
M 241 mm			