

22SVX05T075PT04QBE | Configuration Summary

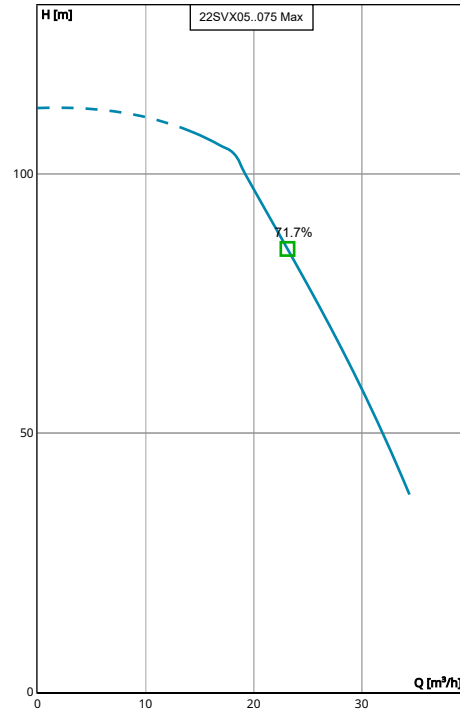

Take the efficiency and low lifetime costs of e-SV multistage pumps to new levels with hydrovar® X – first-class pump management that optimises connectivity, sustainability and performance. Hydrovar® X brings the best energy efficiency performances with its frequency converter coupled with the ultimate synchronous motor, manufactured by Xylem integrating decades of expertise and know-how in pumping solutions.



Performance according to ISO 9906:2012

PUMP

Installation	Pump Size
Complete Pump	22SV
Hydrovar Name	
hydrovar X+	

MATERIALS

Pump Body Material	Impeller Material
Stainless Steel (AISI 304)	Stainless Steel (AISI 304)

SEAL

Type of Seal	Rotating Face
Mechanical Seals	Silicon Carbide
Name	Stationary Face
Q1BEGG	Resin Impregnated Carbon
	Elastomers
	EPDM
	Springs
	AISI 316
	Metal Components
	AISI 316
	Min Temperature
	-30.0 °C
	Max Temperature
	120.0 °C

STANDARD OPTIONS

Special Configuration
Please Select

MOTOR

Poles	Power
2	7.5 kW
	Phase (~)
	3
	Voltage
	380-480 V

FLANGE

Flange
[T] = Oval Flanges (AISI 304)

VFD

Phase	Supply Voltage
3	380-480 V

22SVX05T075PT04QBE | Product Details

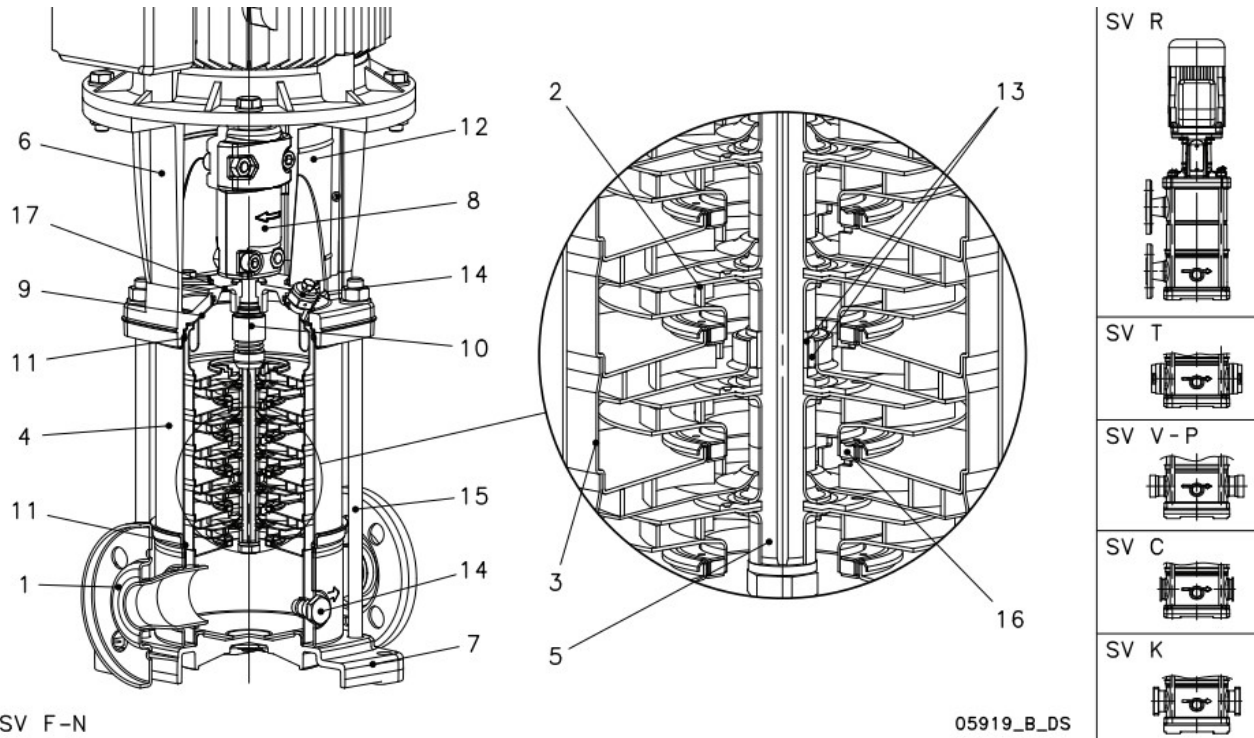

Construction Materials

Pump body (1) Stainless steel / AISI 304	Shaft (5) Stainless steel / AISI 304	Seal plate (9) Stainless steel / AISI 304	Shaft sleeve and bushing (13) Tungsten carbide
Impeller (2) Stainless steel / AISI 304	Adapter (6) Cast Iron / ASTM Class 35	Mechanical seal (10) See Seal section	Fill / Drain plugs (14) Stainless steel / AISI 304
Diffuser (3) Stainless steel / AISI 304	Base (7) Aluminium	Elastomers (11) See Seal section	Tie rods (15) Galvanized steel
Outer sleeve (4) Stainless steel / AISI 304	Coupling (8) Aluminium	Coupling protection (12) Stainless steel / AISI 304	Wear ring (16) Technopolymer PPS
Seal gland (17) Stainless steel / AISI 304			

Motor

Motor Name EXM132B5SV/4.075C	Rated power 7.5 kW	Enclosure IP 55	ICL F
Phase 3	IE Class IE5	Frame Size 132	Standard IEC
Voltage 380-480 V	Motor Vendor Xylem		
Speed 3600.0 rpm			
Rated Current 13.7 A			

22SVX05T075PT04QBE | Hydraulic Data & Performance Curve

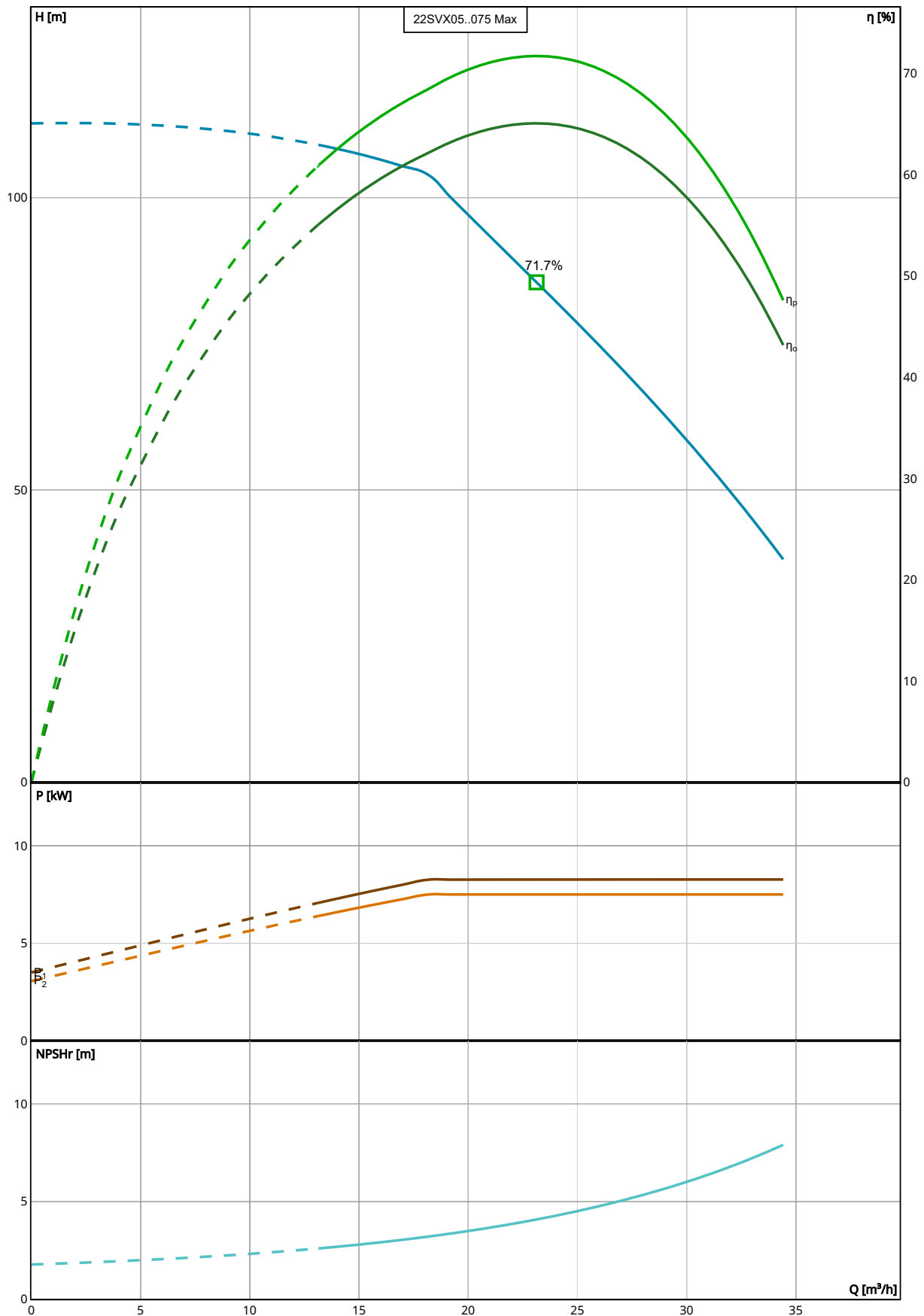

Performance according to ISO 9906:2012

Selection

Series	Standby Pumps
e-SV hydrovar X	No Standby Pump
Name	
22SVX05..075	
Stages	
5	
Frequency	
50 Hz	
Acceptance Grade	
Manufacturer's Standard	
System Type	
Single Pump	
Operating Pumps	
1	

Fluid and Operating Conditions

Fluid Type	Density
Water	1,000 kg/m ³
Fluid Temperature	Dynamic Viscosity
4 °C	0.002 Pa·s
Specific Gravity	Fluid Vapor Pressure
1	8.14 mbar
	Atmospheric Pressure
	1,013.53 mbar
	Elevation
	0 m
	Ambient Temperature
	20 °C
	NPSH Available
	10.27 m
	Submergence
	0 m

Design Curve

Rated Speed	BEP
3,600 RPM	71.71 %
Min Flow	BEP Flow
13.14 m ³ /h	23.13 m ³ /h
Max Flow	BEP Head
34.42 m ³ /h	85.52 m
H@QMin	Max Operating Pressure
109.02 m	11,040.81 mbar
H@QMax	Max P2
38.15 m	7.51 kW

22SVX05T075PT04QBE | Dimensional Data & Drawing

Dimensions

There is no information available for the given configuration.