

15SVX09N110PT04QBE | Configuration Summary

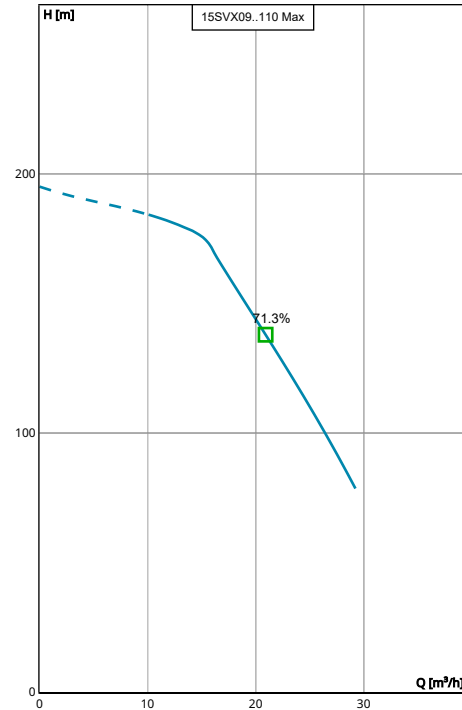

Take the efficiency and low lifetime costs of e-SV multistage pumps to new levels with hydrovar® X – first-class pump management that optimises connectivity, sustainability and performance. Hydrovar® X brings the best energy efficiency performances with its frequency converter coupled with the ultimate synchronous motor, manufactured by Xylem integrating decades of expertise and know-how in pumping solutions.



Performance according to ISO 9906:2012

PUMP

Installation	Pump Size
Complete Pump	15SV
Hydrovar Name	
hydrovar X+	

MATERIALS

Pump Body Material	Impeller Material
Stainless Steel (AISI 316L)	Stainless Steel (AISI 316L)

SEAL

Type of Seal	Rotating Face
Mechanical Seals	Silicon Carbide
Name	Stationary Face
Q1BEGG	Resin Impregnated Carbon
	Elastomers
	EPDM
	Springs
	AISI 316
	Metal Components
	AISI 316
	Min Temperature
	-30.0 °C
	Max Temperature
	120.0 °C

STANDARD OPTIONS

Special Configuration
Please Select

MOTOR

Poles	Power
2	11 kW
	Phase (~)
	3
	Voltage
	380-480 V

FLANGE

Flange
[N] = Round Flanges (AISI 316)

VFD

Phase	Supply Voltage
3	380-480 V

15SVX09N110PT04QBE | Product Details

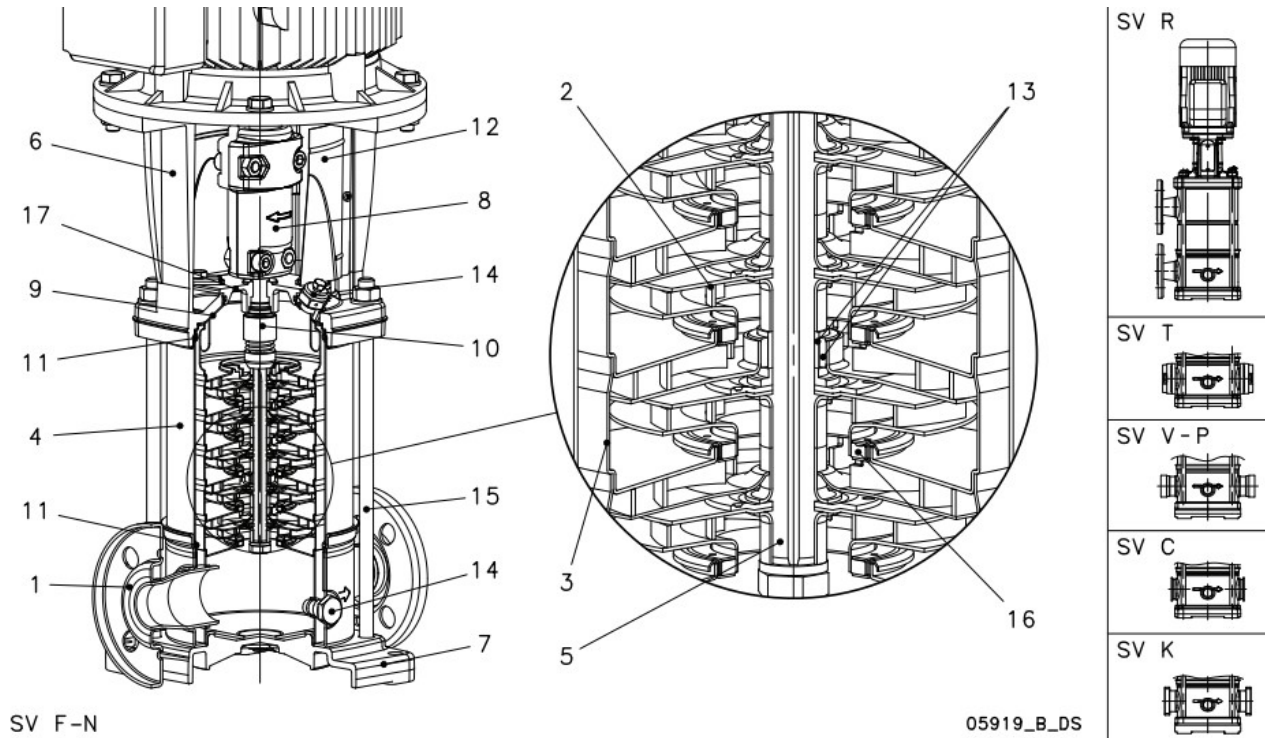

05919_B_DS

Construction Materials

Pump body (1) Stainless steel / AISI 316L	Shaft (5) Stainless steel / AISI 316	Seal plate (9) Stainless steel / AISI 316L	Shaft sleeve and bushing (13) Tungsten carbide
Impeller (2) Stainless steel / AISI 316L	Adapter (6) Cast Iron / ASTM Class 35	Mechanical seal (10) See Seal section	Fill / Drain plugs (14) Stainless steel / AISI 316
Diffuser (3) Stainless steel / AISI 316L	Base (7) Aluminium	Elastomers (11) See Seal section	Tie rods (15) Stainless steel / AISI 431
Outer sleeve (4) Stainless steel / AISI 316L	Coupling (8) Aluminium	Coupling protection (12) Stainless steel / AISI 304	Wear ring (16) Technopolymer PPS
Seal gland (17) Stainless steel / AISI 316			

Motor

Motor Name EXM160B5SV/4.110C	Rated power 11 kW	Enclosure IP 55	ICL F
Phase 3	IE Class IE5	Frame Size 160	Standard IEC
Voltage 380-480 V	Motor Vendor Xylem		
Speed 3600.0 rpm			
Rated Current 19.8 A			

15SVX09N110PT04QBE | Hydraulic Data & Performance Curve

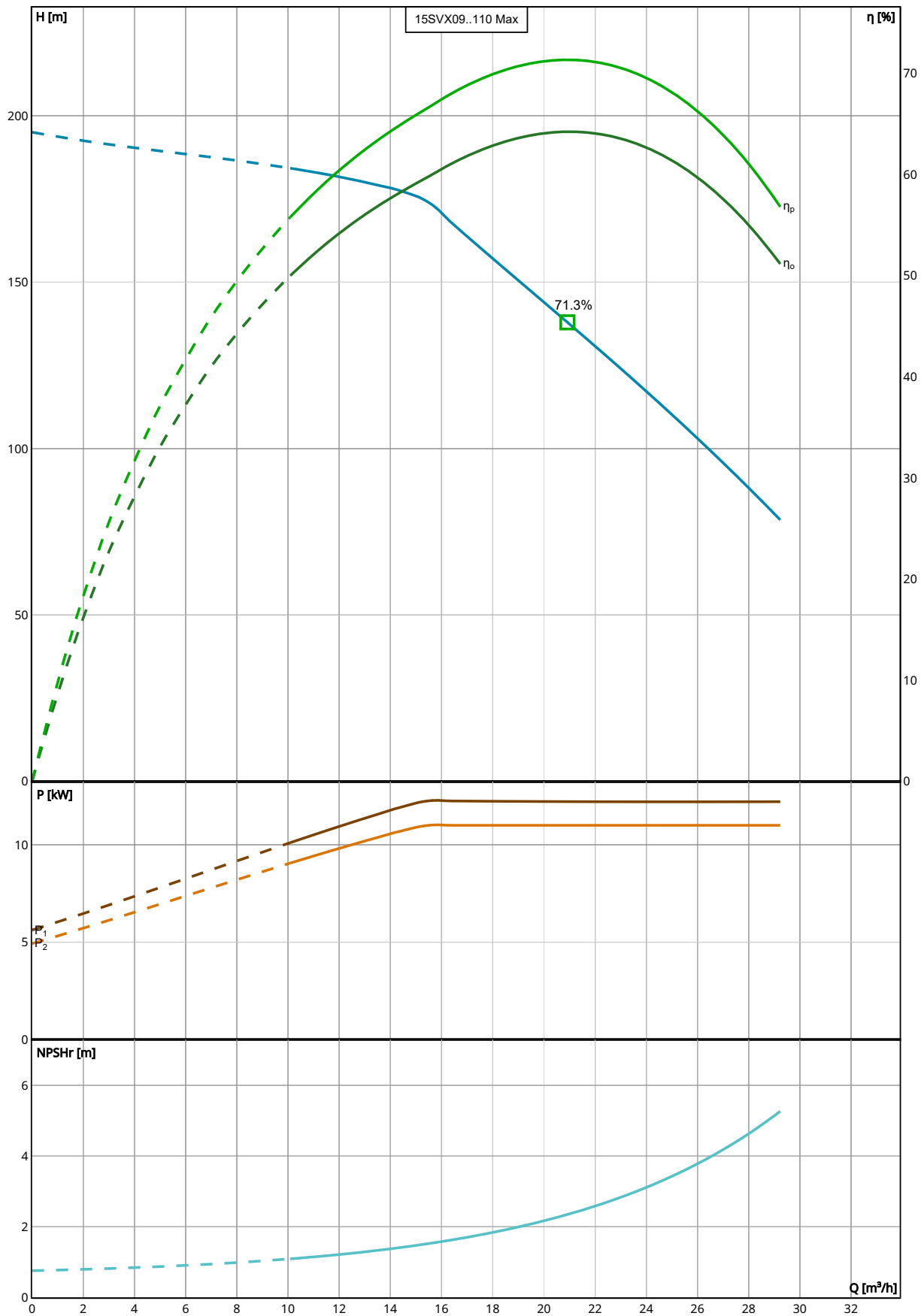

Performance according to ISO 9906:2012

Selection

Series	Standby Pumps
e-SV hydrovar X	No Standby Pump
Name	
15SVX09..110	
Stages	
9	
Frequency	
50 Hz	
Acceptance Grade	
Manufacturer's Standard	
System Type	
Single Pump	
Operating Pumps	
1	

Fluid and Operating Conditions

Fluid Type	Density
Water	1,000 kg/m ³
Fluid Temperature	Dynamic Viscosity
4 °C	0.002 Pa·s
Specific Gravity	Fluid Vapor Pressure
1	8.14 mbar
	Atmospheric Pressure
	1,013.53 mbar
	Elevation
	0 m
	Ambient Temperature
	20 °C
	NPSH Available
	10.27 m
	Submergence
	0 m

Design Curve

Rated Speed	BEP
3,600 RPM	71.33 %
Min Flow	BEP Flow
10.09 m ³ /h	20.92 m ³ /h
Max Flow	BEP Head
29.23 m ³ /h	137.94 m
H@QMin	Max Operating Pressure
184.25 m	19,100.68 mbar
H@QMax	Max P2
78.61 m	11.02 kW

15SVX09N110PT04QBE | Dimensional Data & Drawing

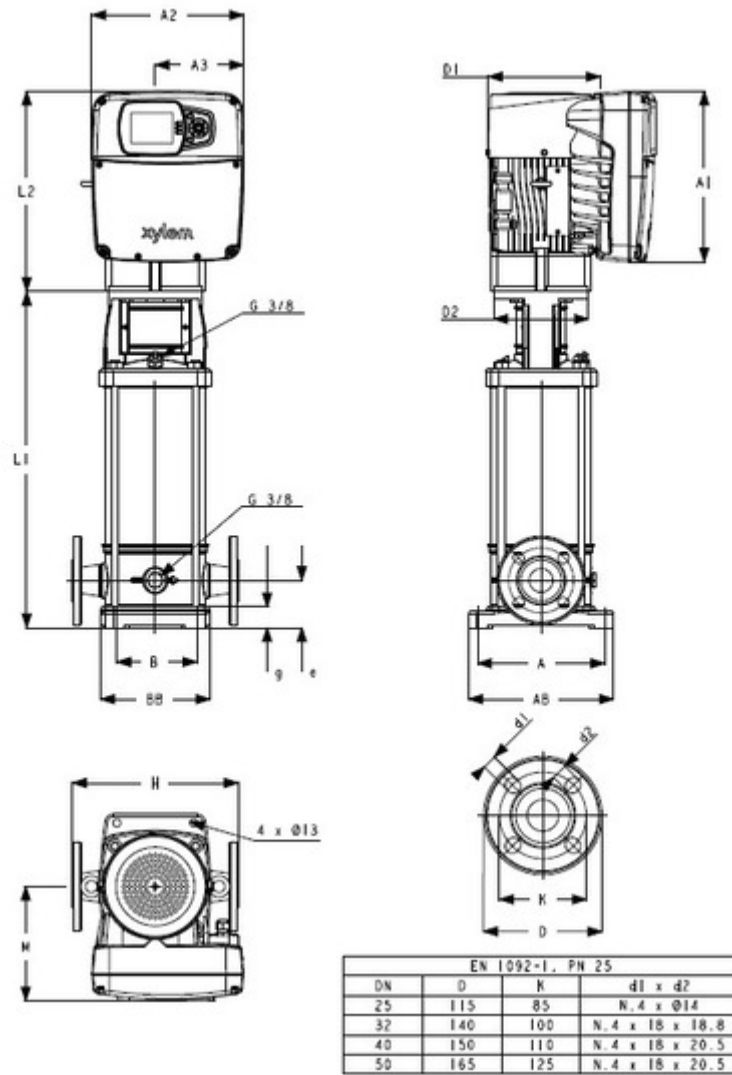

Drawing is preliminary and is subject to change.

Dimensions

A 215 mm	D2 350 mm	L1 852 mm	L2 404 mm
AB 245 mm	e 90 mm	DN 50 mm	D1 220 mm
B 130 mm	g 30 mm	Weight (Pump) 34.6 kg	A1 329 mm
BB 185 mm	H 300 mm	Total Weight 86.6 kg	A2 302 mm
A3 175 mm			
M 241 mm			