

5SVX23F055PT04QBE | Configuration Summary

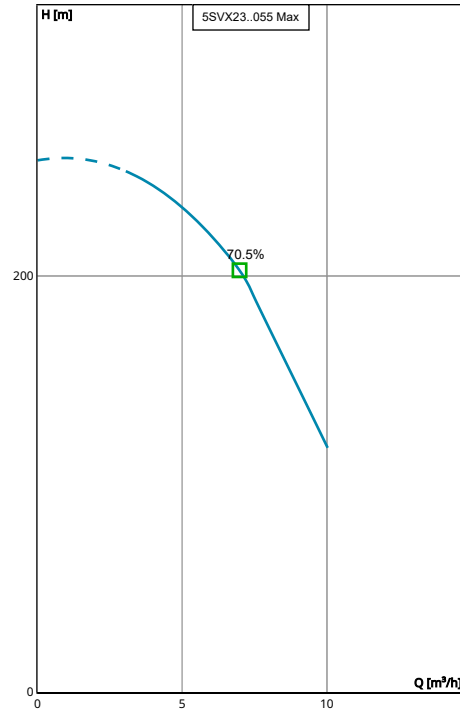

Take the efficiency and low lifetime costs of e-SV multistage pumps to new levels with hydrovar® X – first-class pump management that optimises connectivity, sustainability and performance. Hydrovar® X brings the best energy efficiency performances with its frequency converter coupled with the ultimate synchronous motor, manufactured by Xylem integrating decades of expertise and know-how in pumping solutions.



Performance according to ISO 9906:2012

PUMP

Installation Complete Pump	Pump Size 5SV
Hydrovar Name hydrovar X+	

MATERIALS

Pump Body Material Stainless Steel (AISI 304)	Impeller Material Stainless Steel (AISI 304)
---	--

SEAL

Type of Seal Mechanical Seals	Rotating Face Silicon Carbide
Name Q1BEGG	Stationary Face Resin Impregnated Carbon
	Elastomers EPDM
	Springs AISI 316
	Metal Components AISI 316
	Min Temperature -30.0 °C
	Max Temperature 120.0 °C

STANDARD OPTIONS

Special Configuration
Please Select

MOTOR

Poles 2	Power 5.5 kW
	Phase (~) 3
	Voltage 380-480 V

FLANGE

Flange
[F] = Round Flanges (AISI 304)

VFD

Phase 3	Supply Voltage 380-480 V
-------------------	------------------------------------

5SVX23F055PT04QBE | Product Details

SV F-N



05920_B_DS

Construction Materials

Pump body (1) Stainless steel / AISI 304	Shaft (5) Stainless steel / AISI 304	Seal housing (9) Stainless steel / AISI 304	Shaft sleeve and bushing (13) Tungsten carbide
Impeller (2) Stainless steel / AISI 304	Adapter (6) Cast Iron / ASTM Class 35	Mechanical seal (10) See Seal section	Fill / Drain plugs (14) Stainless steel / AISI 304
Diffuser (3) Stainless steel / AISI 304	Base (7) Aluminium	Elastomers (11) See Seal section	Tie rods (15) Galvanized steel
Outer sleeve (4) Stainless steel / AISI 304	Coupling (8) Aluminium	Coupling protection (12) Stainless steel / AISI 304	Wear ring (16) Technopolymer PPS

Motor

Motor Name EXM132B5SV/4.055B	Rated power 5.5 kW	Enclosure IP 55	ICL F
Phase 3	IE Class IE5	Frame Size 132	Standard IEC
Voltage 380-480 V	Motor Vendor Xylem		
Speed 3600.0 rpm			
Rated Current 10.1 A			

5SVX23F055PT04QBE | Hydraulic Data & Performance Curve

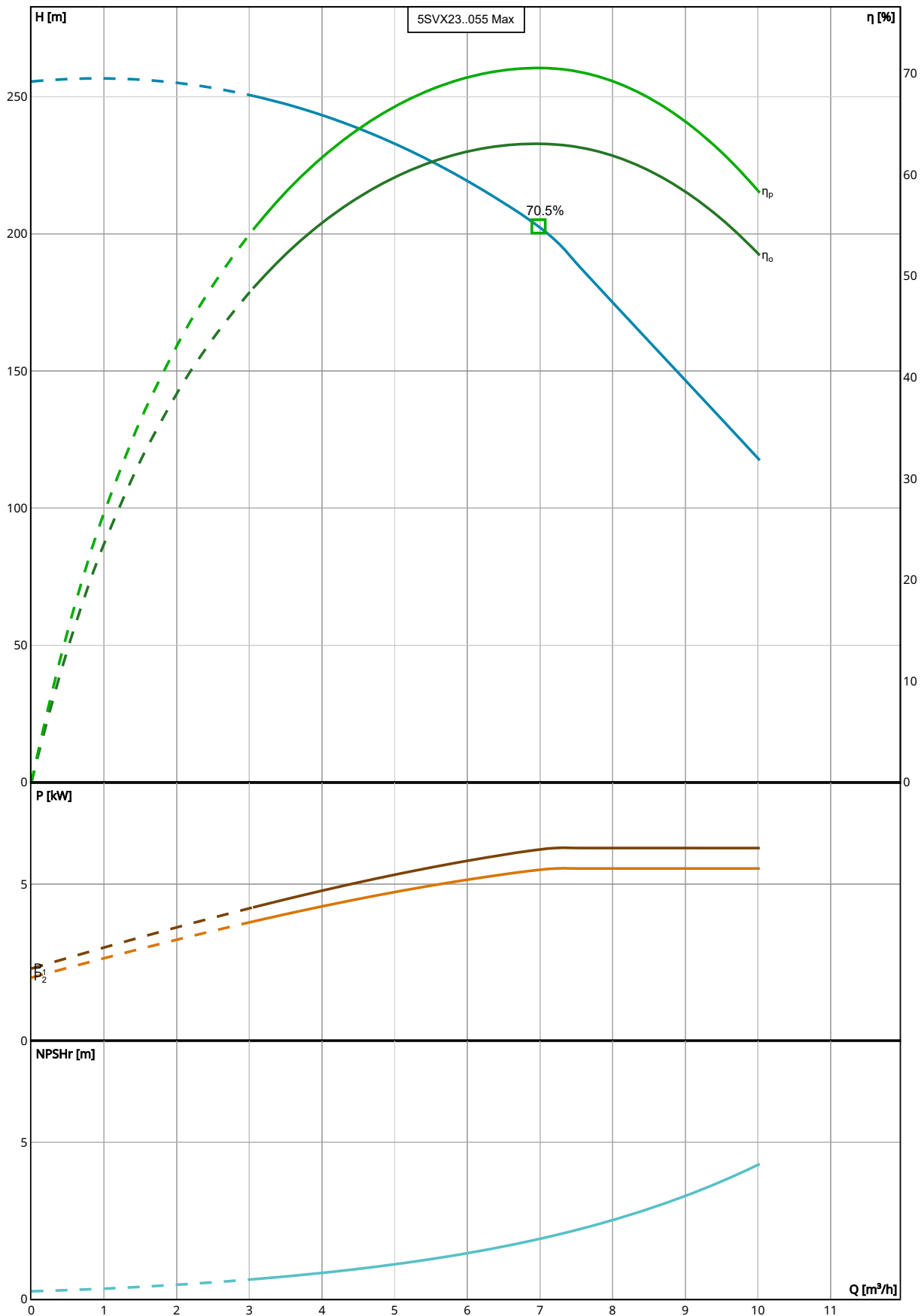

Performance according to ISO 9906:2012

Selection

Series	Standby Pumps
e-SV hydrovar X	No Standby Pump
Name	
5SVX23..055	
Stages	
23	
Frequency	
50 Hz	
Acceptance Grade	
Manufacturer's Standard	
System Type	
Single Pump	
Operating Pumps	
1	

Fluid and Operating Conditions

Fluid Type	Density
Water	1,000 kg/m ³
Fluid Temperature	Dynamic Viscosity
4 °C	0.002 Pa·s
Specific Gravity	Fluid Vapor Pressure
1	8.14 mbar
	Atmospheric Pressure
	1,013.53 mbar
	Elevation
	0 m
	Ambient Temperature
	20 °C
	NPSH Available
	10.27 m
	Submergence
	0 m

Design Curve

Rated Speed	BEP
3,600 RPM	70.53 %
Min Flow	BEP Flow
3.05 m ³ /h	6.98 m ³ /h
Max Flow	BEP Head
10.02 m ³ /h	202.72 m
H@QMin	Max Operating Pressure
250.33 m	25,134.05 mbar
H@QMax	Max P2
117.46 m	5.5 kW

5SVX23F055PT04QBE | Dimensional Data & Drawing

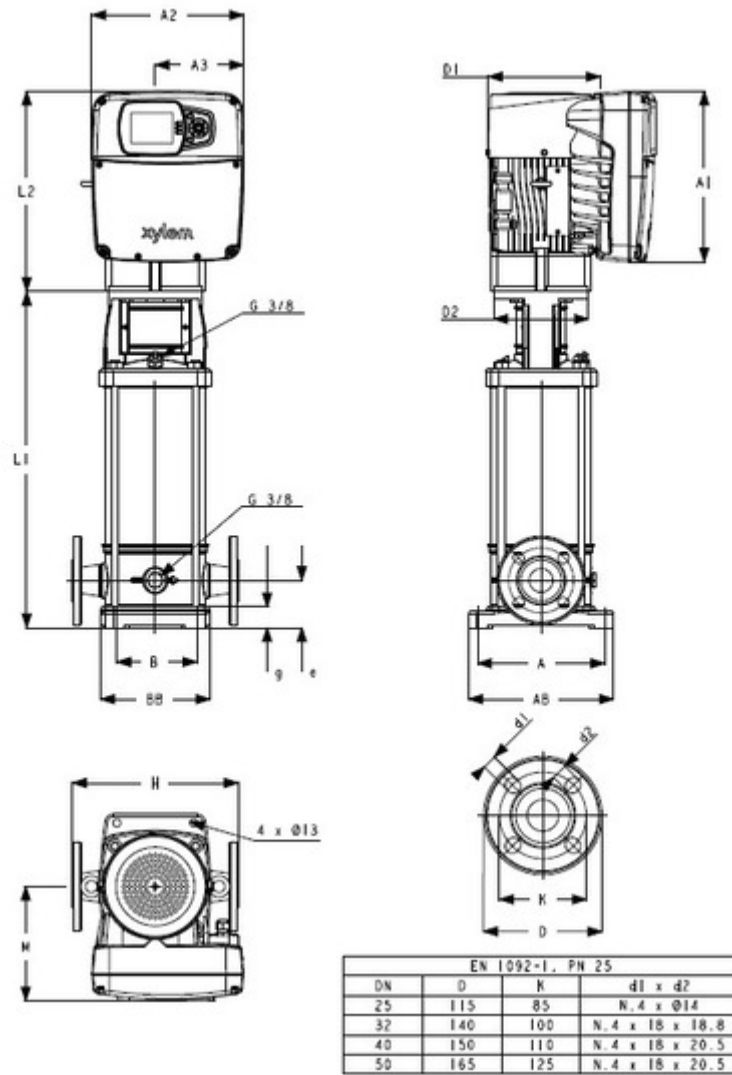

Drawing is preliminary and is subject to change.

Dimensions

A 180 mm	D2 300 mm	L1 843 mm	L2 349 mm
AB 210 mm	e 75 mm	DN 32 mm	D1 179 mm
B 100 mm	g 25 mm	Weight (Pump) 23.5 kg	A1 289 mm
BB 150 mm	H 250 mm	Total Weight 51.5 kg	A2 256 mm
A3 149 mm			
M 194 mm			