

## 5SVX19F040PT04QBE | Configuration Summary

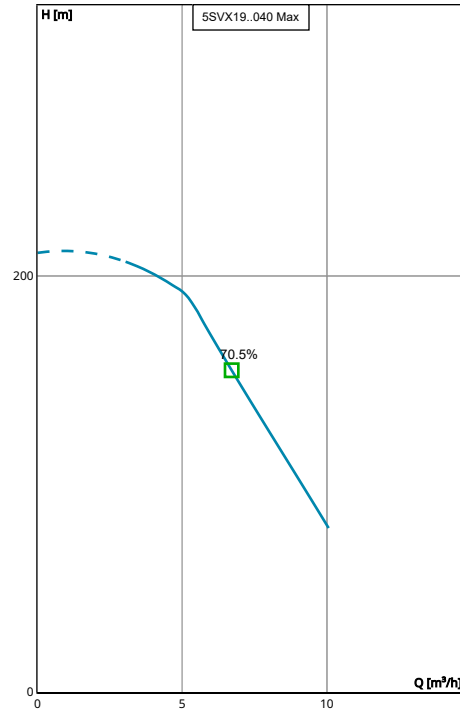

Take the efficiency and low lifetime costs of e-SV multistage pumps to new levels with hydrovar® X – first-class pump management that optimises connectivity, sustainability and performance. Hydrovar® X brings the best energy efficiency performances with its frequency converter coupled with the ultimate synchronous motor, manufactured by Xylem integrating decades of expertise and know-how in pumping solutions.



Performance according to ISO 9906:2012

### PUMP

<b>Installation</b>	<b>Pump Size</b>
Complete Pump	5SV
<b>Hydrovar Name</b>	
hydrovar X+	

### MATERIALS

<b>Pump Body Material</b>	<b>Impeller Material</b>
Stainless Steel (AISI 304)	Stainless Steel (AISI 304)

### SEAL

<b>Type of Seal</b>	<b>Rotating Face</b>
Mechanical Seals	Silicon Carbide
<b>Name</b>	<b>Stationary Face</b>
Q1BEGG	Resin Impregnated Carbon
	<b>Elastomers</b>
	EPDM
	<b>Springs</b>
	AISI 316
	<b>Metal Components</b>
	AISI 316
	<b>Min Temperature</b>
	-30.0 °C
	<b>Max Temperature</b>
	120.0 °C

### STANDARD OPTIONS

Special Configuration  
Please Select

### MOTOR

<b>Poles</b>	<b>Power</b>
2	4 kW
	<b>Phase (~)</b>
	3
	<b>Voltage</b>
	380-480 V

### FLANGE

Flange  
[F] = Round Flanges (AISI 304)

### VFD

<b>Phase</b>	<b>Supply Voltage</b>
3	380-480 V

**5SVX19F040PT04QBE** | Product Details

SV F-N

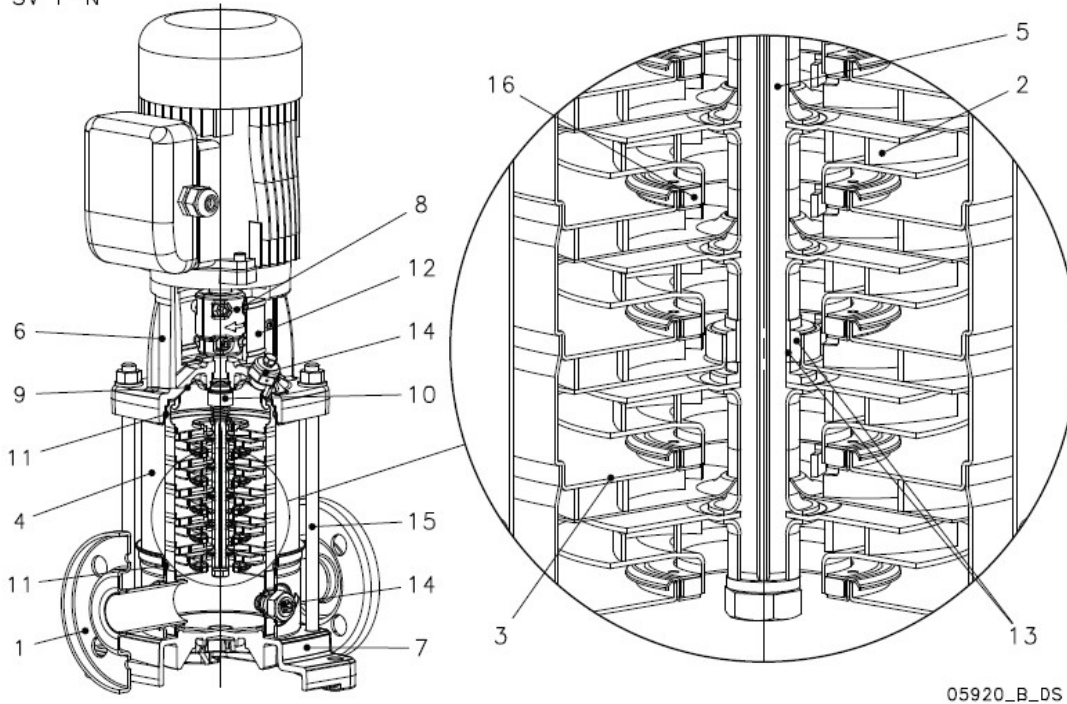

05920\_B\_DS

**Construction Materials**

<b>Pump body (1)</b> Stainless steel / AISI 304	<b>Shaft (5)</b> Stainless steel / AISI 304	<b>Seal housing (9)</b> Stainless steel / AISI 304	<b>Shaft sleeve and bushing (13)</b> Tungsten carbide
<b>Impeller (2)</b> Stainless steel / AISI 304	<b>Adapter (6)</b> Cast Iron / ASTM Class 35	<b>Mechanical seal (10)</b> See Seal section	<b>Fill / Drain plugs (14)</b> Stainless steel / AISI 304
<b>Diffuser (3)</b> Stainless steel / AISI 304	<b>Base (7)</b> Aluminium	<b>Elastomers (11)</b> See Seal section	<b>Tie rods (15)</b> Galvanized steel
<b>Outer sleeve (4)</b> Stainless steel / AISI 304	<b>Coupling (8)</b> Aluminium	<b>Coupling protection (12)</b> Stainless steel / AISI 304	<b>Wear ring (16)</b> Technopolymer PPS

**Motor**

<b>Motor Name</b> EXM112B14SV/4.040B	<b>Rated power</b> 4 kW	<b>Enclosure</b> IP 55	<b>ICL</b> F
<b>Phase</b> 3	<b>IE Class</b> IE5	<b>Frame Size</b> 112	<b>Standard</b> IEC
<b>Voltage</b> 380-480 V	<b>Motor Vendor</b> Xylem		
<b>Speed</b> 3600.0 rpm			
<b>Rated Current</b> 7.73 A			

### 5SVX19F040PT04QBE | Hydraulic Data & Performance Curve

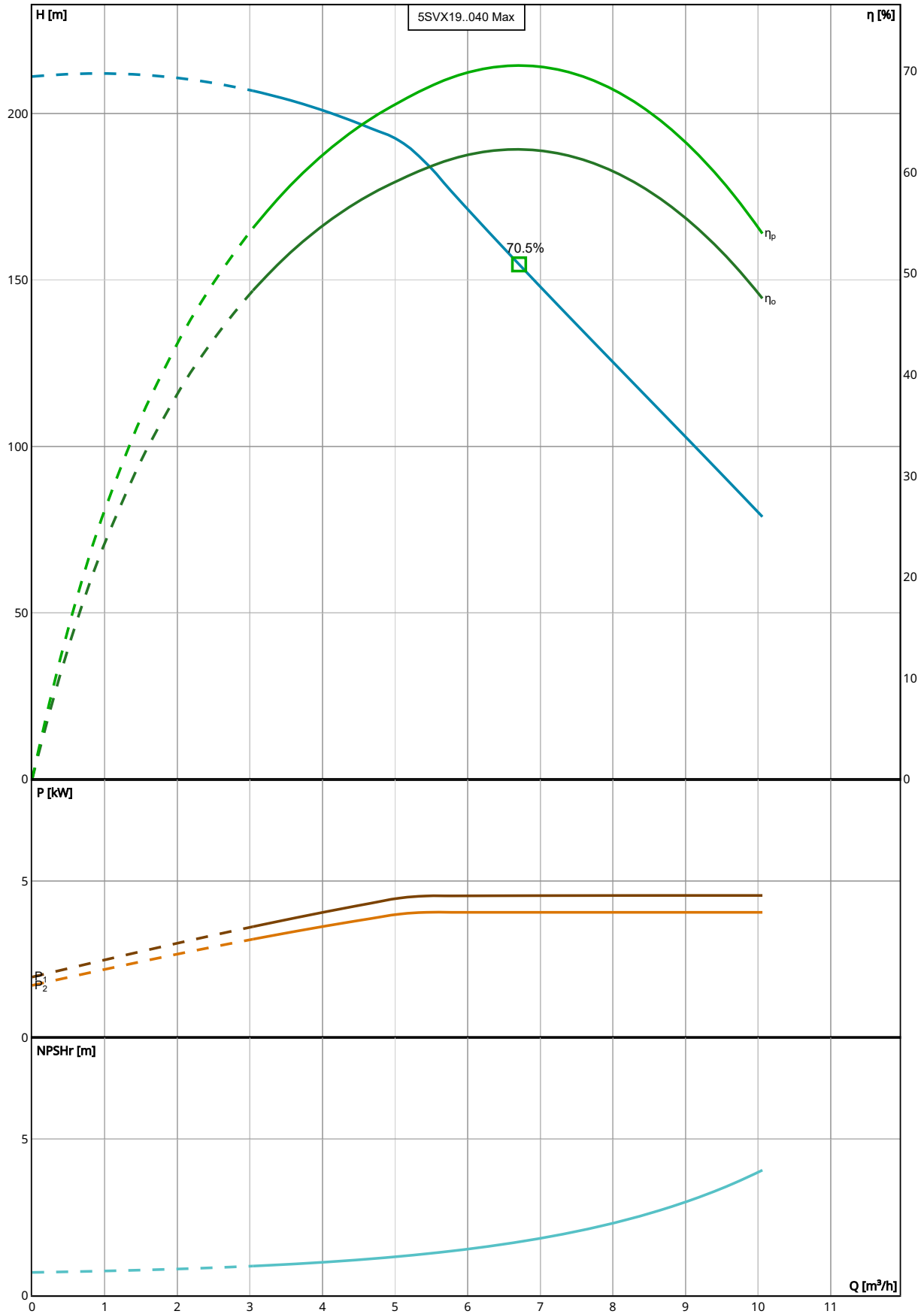

Performance according to ISO 9906:2012

**Selection**

Series	Standby Pumps
e-SV hydrovar X	No Standby Pump
<b>Name</b>	
5SVX19..040	
<b>Stages</b>	
19	
<b>Frequency</b>	
50 Hz	
<b>Acceptance Grade</b>	
Manufacturer's Standard	
<b>System Type</b>	
Single Pump	
<b>Operating Pumps</b>	
1	

**Fluid and Operating Conditions**

<b>Fluid Type</b>	Density
Water	1,000 kg/m <sup>3</sup>
<b>Fluid Temperature</b>	Dynamic Viscosity
4 °C	0.002 Pa·s
<b>Specific Gravity</b>	Fluid Vapor Pressure
1	8.14 mbar
	Atmospheric Pressure
	1,013.53 mbar
	Elevation
	0 m
	Ambient Temperature
	20 °C
	NPSH Available
	10.27 m
	Submergence
	0 m

**Design Curve**

<b>Rated Speed</b>	BEP
3,600 RPM	70.54 %
<b>Min Flow</b>	BEP Flow
3.04 m <sup>3</sup> /h	6.71 m <sup>3</sup> /h
<b>Max Flow</b>	BEP Head
10.06 m <sup>3</sup> /h	154.69 m
<b>H@QMin</b>	Max Operating Pressure
206.83 m	20,761.75 mbar
<b>H@QMax</b>	Max P2
78.89 m	4 kW

**5SVX19F040PT04QBE** | Dimensional Data & Drawing

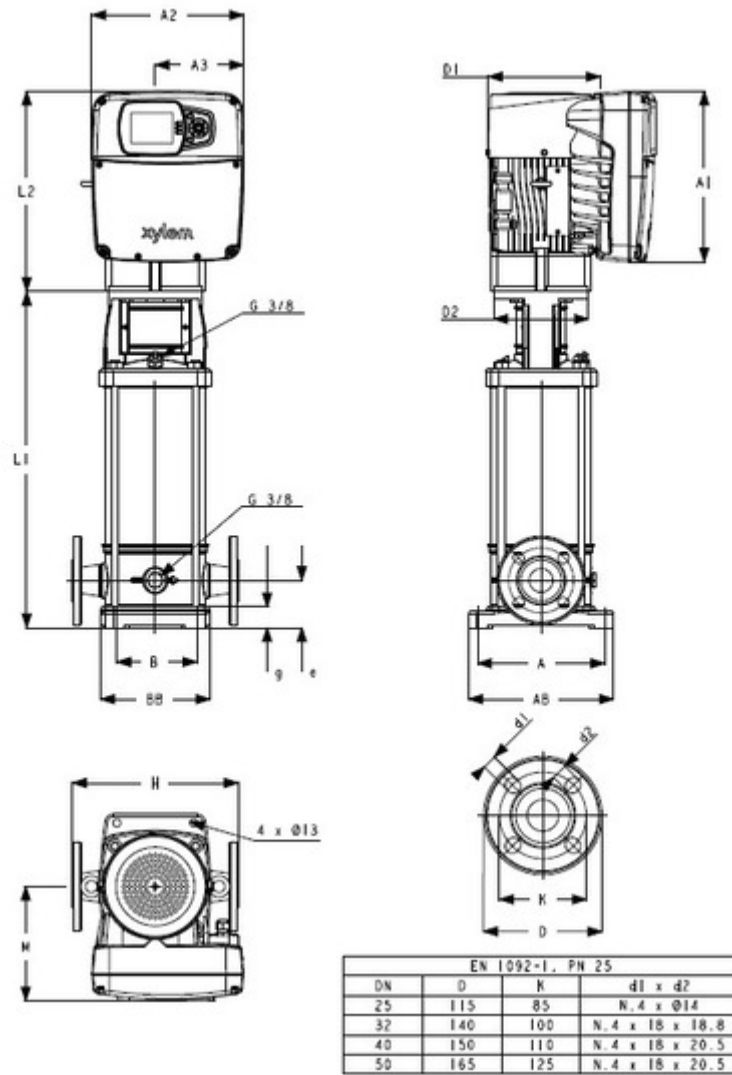

Drawing is preliminary and is subject to change.

**Dimensions**

<b>A</b> 180 mm	<b>D2</b> 160 mm	<b>L1</b> 723 mm	<b>L2</b> 339 mm
<b>AB</b> 210 mm	<b>e</b> 75 mm	<b>DN</b> 32 mm	<b>D1</b> 179 mm
<b>B</b> 100 mm	<b>g</b> 25 mm	<b>Weight (Pump)</b> 18.5 kg	<b>A1</b> 289 mm
<b>BB</b> 150 mm	<b>H</b> 250 mm	<b>Total Weight</b> 42.98 kg	<b>A2</b> 256 mm
<b>A3</b> 149 mm			
<b>M</b> 194 mm			