

## 5SVE06F011P0M/2 | Configuration Summary

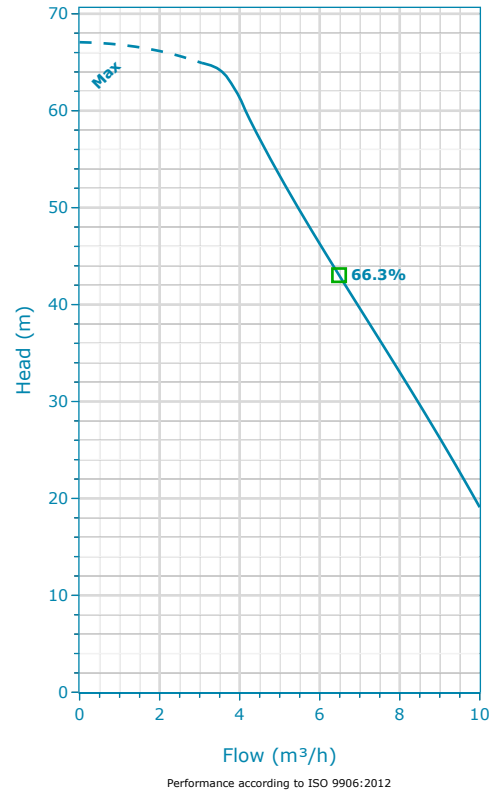

The SVE pump is a non-self priming vertical multistage pump coupled with eSM drive. The pump casing is available with different configurations and connection types.



### PUMP

**Installation**  
Complete Pump

### MATERIALS

<b>Pump Body Material</b> Stainless Steel (AISI 304)	<b>Impeller Material</b> Stainless Steel (AISI 304)
---	--

### SEAL

<b>Type of Seal</b> Mechanical Seals	<b>Rotating Face</b> Silicon Carbide
<b>Name</b> Q1BEGG	<b>Stationary Face</b> Resin Impregnated Carbon
	<b>Elastomers</b> EPDM
	<b>Springs</b> AISI 316
	<b>Metal Components</b> AISI 316
	<b>Min Temperature</b> -30.0 °C
	<b>Max Temperature</b> 120.0 °C

### MOTOR

<b>Poles</b> 2	<b>Power</b> 1.1 kW
	<b>Phase (~)</b> 1
	<b>Voltage</b> 208-240 V

### FLANGE

**Flange**  
[F] = Round Flanges (AISI 304)

**5SVE06F011P0M/2** | Product Details

SV F-N

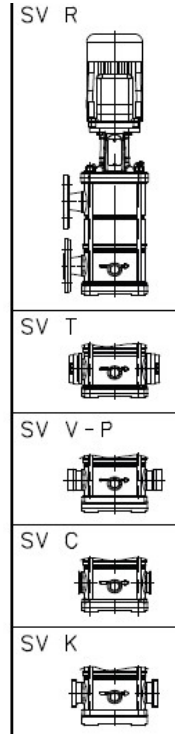
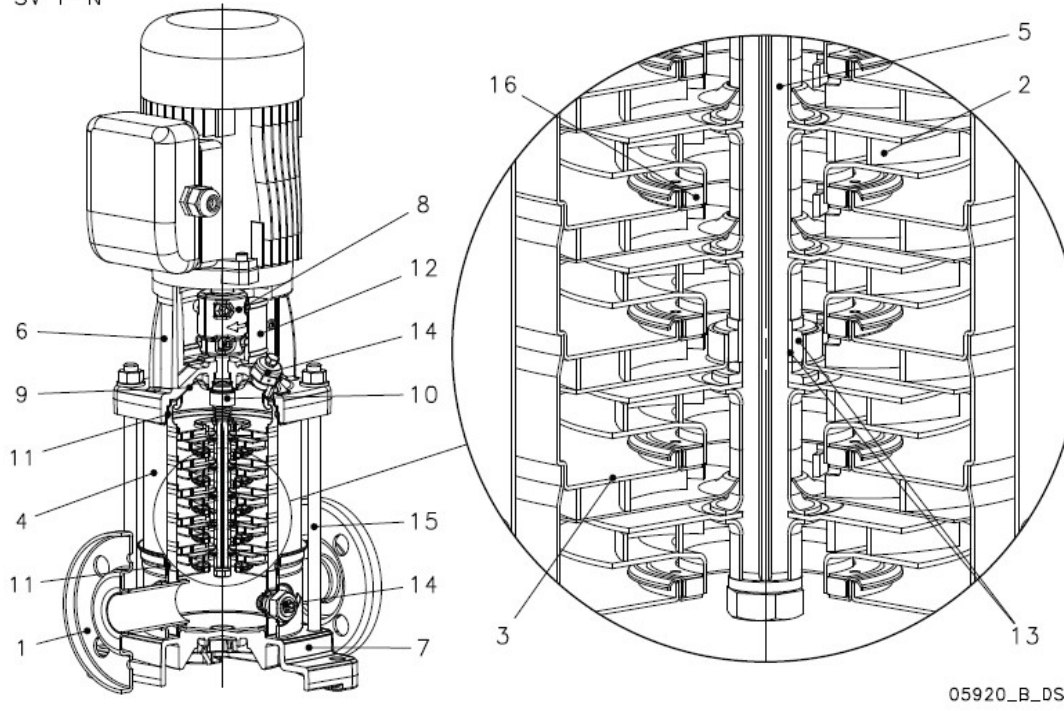

**Construction Materials**

<b>Pump body (1)</b> Stainless steel / AISI 304	<b>Shaft (5)</b> Stainless steel / AISI 304	<b>Seal housing (9)</b> Stainless steel / AISI 304	<b>Shaft sleeve and bushing (13)</b> Tungsten carbide
<b>Impeller (2)</b> Stainless steel / AISI 304	<b>Adapter (6)</b> Cast Iron / ASTM Class 35	<b>Mechanical seal (10)</b> See Seal section	<b>Fill / Drain plugs (14)</b> Stainless steel / AISI 304
<b>Diffuser (3)</b> Stainless steel / AISI 304	<b>Base (7)</b> Aluminium	<b>Elastomers (11)</b> See Seal section	<b>Tie rods (15)</b> Galvanized steel
<b>Outer sleeve (4)</b> Stainless steel / AISI 304	<b>Coupling (8)</b> Aluminium	<b>Coupling protection (12)</b> Stainless steel / AISI 304	<b>Wear ring (16)</b> Technopolymer PPS

**Motor**

<b>Motor Name</b> ESM90R/111 SVE	<b>Phase</b> 1	<b>Enclosure</b> IP 55	<b>ICL</b> F
<b>Design</b> e-SM Motor	<b>Rated power</b> 1.1 kW	<b>Frame Size</b> 90R	<b>Standard</b> IEC
<b>Service Factor</b> 1	<b>Rated Current</b> 6.20-5.32 A		
<b>Voltage</b> 208-240 V	<b>Motor Vendor</b> Lowara		
<b>Speed</b> 3600.0 rpm			

**5SVE06F011P0M/2 | Hydraulic Data & Performance Curve**

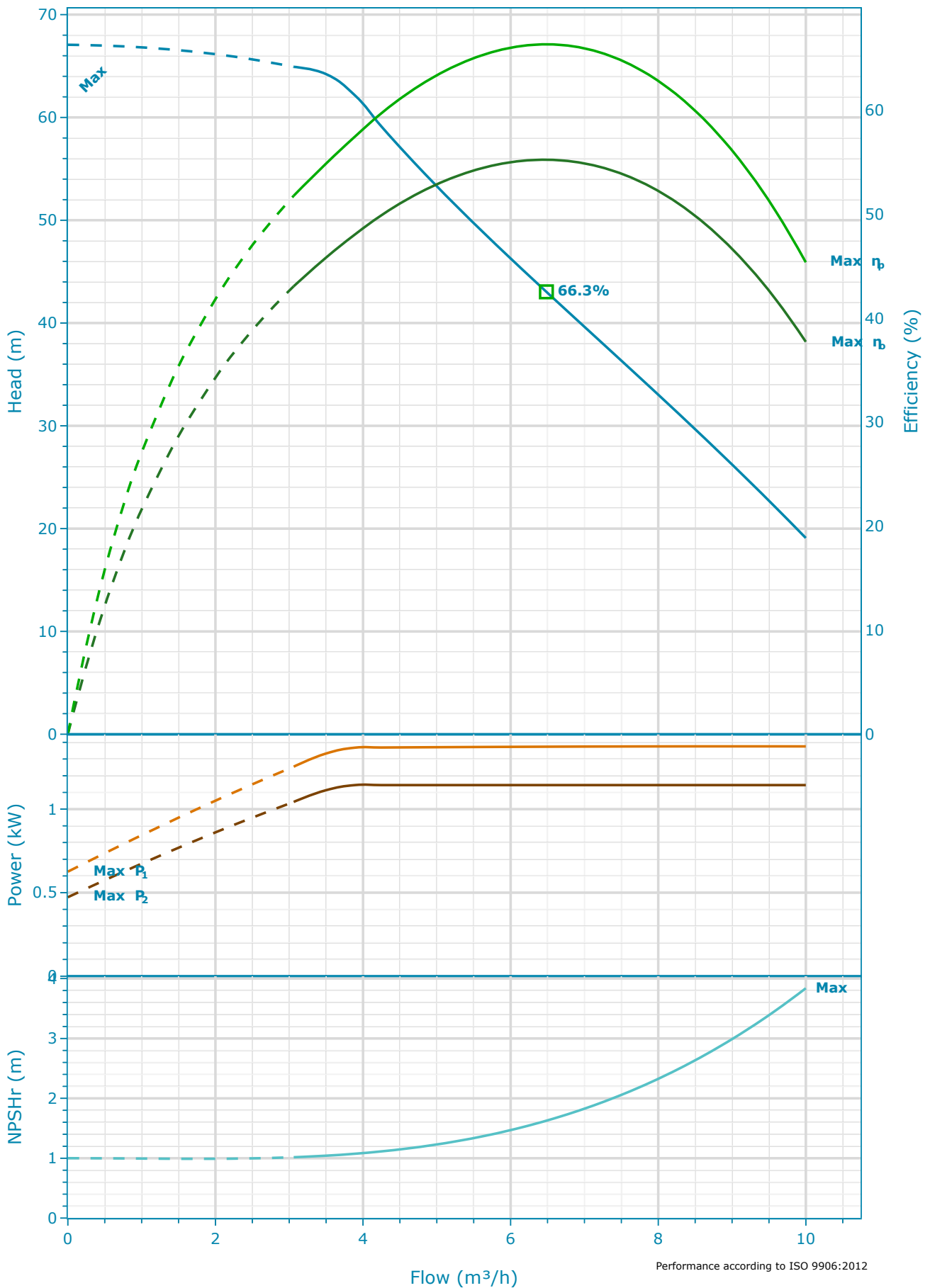

**Selection**

Series Standby Pumps  
e-SVE No Standby Pump

Name  
5SVE06..011

Stages  
6

Frequency  
50 Hz

Acceptance Grade  
Manufacturer's Standard

System Type  
Single Pump

Operating Pumps  
1

**Fluid and Operating Conditions**

Fluid Type Density  
Water 1,000 kg/m<sup>3</sup>

Fluid Temperature Dynamic Viscosity  
4 °C 0.002 Pa·s

Specific Gravity Fluid Vapor Pressure  
1 8.14 mbar

Atmospheric Pressure  
1,013.53 mbar

Elevation  
0 m

Ambient Temperature  
20 °C

NPSH Available  
10.27 m

Submergence  
0 m

**Design Curve**

Rated Speed BEP  
3,600 RPM 66.33 %

Min Flow BEP Flow  
3.06 m<sup>3</sup>/h 6.48 m<sup>3</sup>/h

Max Flow BEP Head  
10 m<sup>3</sup>/h 43.03 m

H@QMin Max Operating Pressure  
64.91 m 6,567.4 mbar

H@QMax Max P2  
19.09 m 1.15 kW

## 5SVE06F011P0M/2 | Dimensional Data & Drawing

1-3-5SVE (F-N)

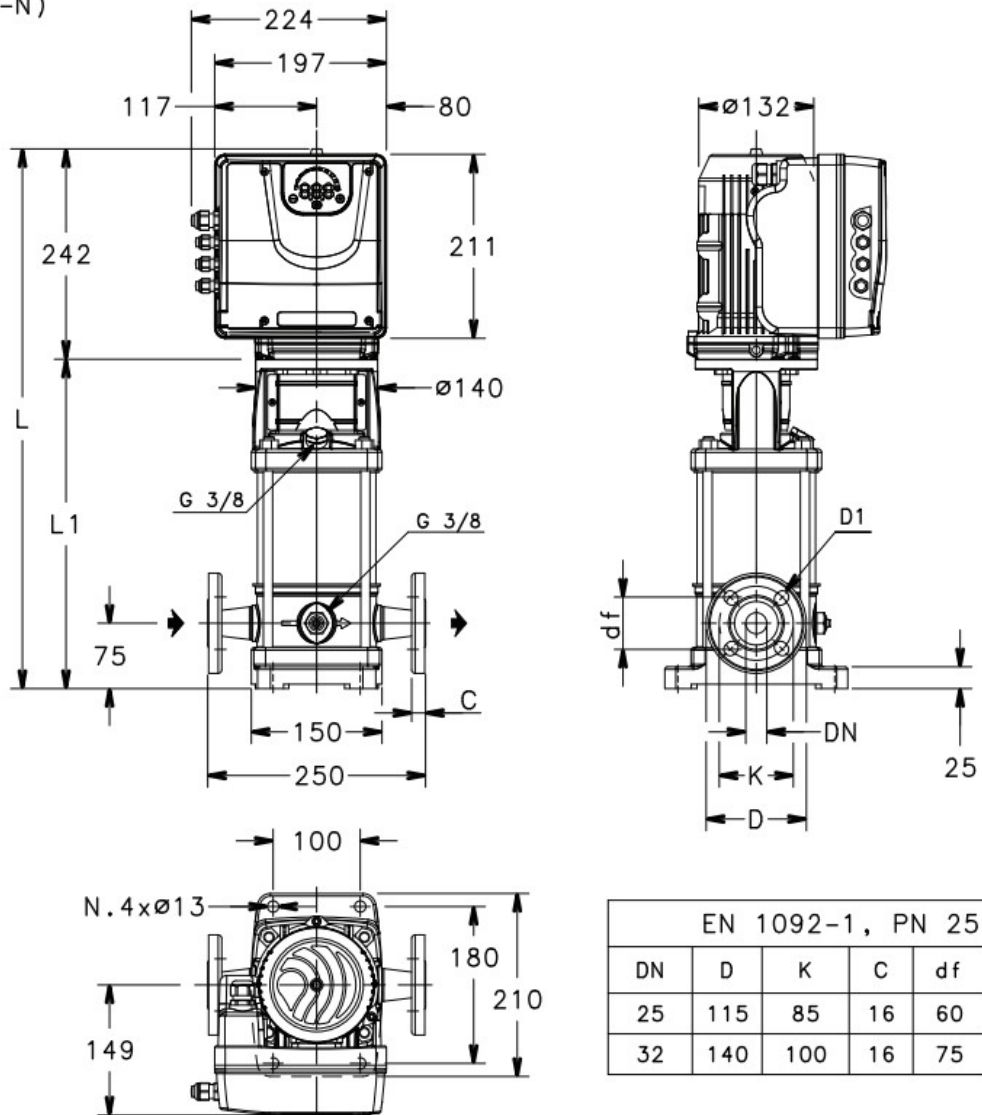

Drawing is preliminary and is subject to change.

### Dimensions

D1	Weight (Pump)
4 x 18	11.3 kg
L	Total Weight
630 mm	20.3 kg
L1	
388 mm	
DN	
32 mm	