

1SVE11F007POT/5 | Configuration Summary

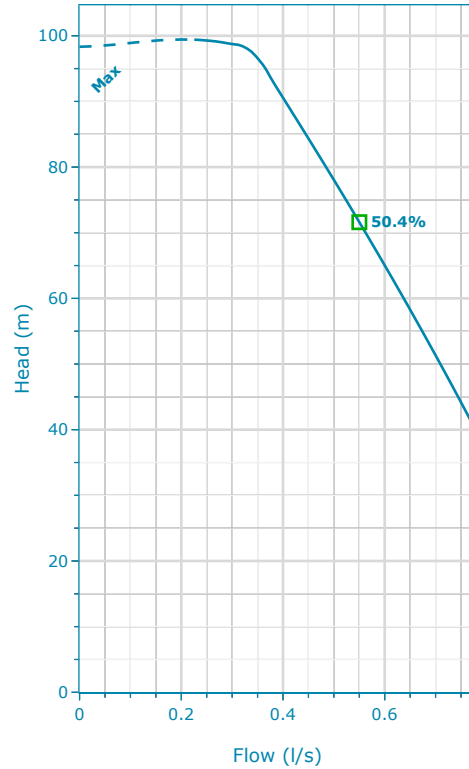

The SVE pump is a non-self priming vertical multistage pump coupled with eSM drive. The pump casing is available with different configurations and connection types.



Performance according to ISO 9906:2012

PUMP

Installation
Complete Pump

MATERIALS

Pump Body Material Stainless Steel (AISI 304)	Impeller Material Stainless Steel (AISI 304)
---	--

SEAL

Type of Seal Mechanical Seals	Rotating Face Silicon Carbide
Name Q1BEGG	Stationary Face Resin Impregnated Carbon
	Elastomers EPDM
	Springs AISI 316
	Metal Components AISI 316
	Min Temperature -30.0 °C
	Max Temperature 120.0 °C

MOTOR

Poles 2	Power 0.75 kW
	Phase (~) 3
	Voltage 208-240/380-460 V

FLANGE

Flange
[F] = Round Flanges (AISI 304)

1SVE11F007POT/5 | Product Details

SV F-N

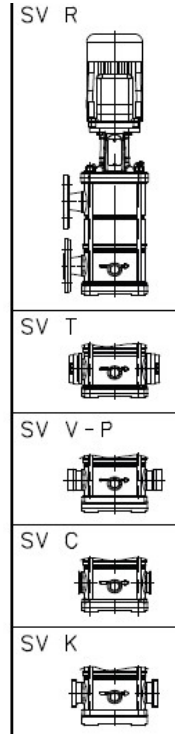
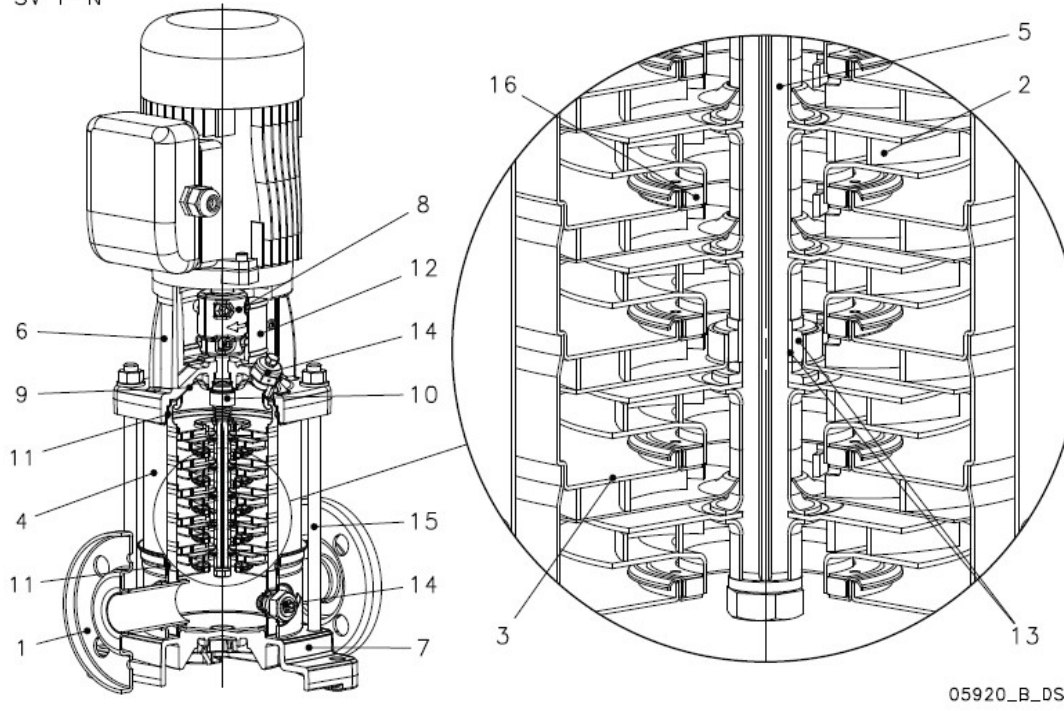

Construction Materials

Pump body (1) Stainless steel / AISI 304	Shaft (5) Stainless steel / AISI 304	Seal housing (9) Stainless steel / AISI 304	Shaft sleeve and bushing (13) Tungsten carbide
Impeller (2) Stainless steel / AISI 304	Adapter (6) Cast Iron / ASTM Class 35	Mechanical seal (10) See Seal section	Fill / Drain plugs (14) Stainless steel / AISI 304
Diffuser (3) Stainless steel / AISI 304	Base (7) Aluminium	Elastomers (11) See Seal section	Tie rods (15) Galvanized steel
Outer sleeve (4) Stainless steel / AISI 304	Coupling (8) Aluminium	Coupling protection (12) Stainless steel / AISI 304	Wear ring (16) Technopolymer PPS

Motor

Motor Name ESM90R/307 SVE	Phase 3	Enclosure IP 55	ICL F
Design e-SM Motor	Rated power 0.75 kW	Frame Size 90R	Standard IEC
Service Factor 1	Rated Current 3.74-3.28/2.43-2.20 A		
Voltage 208-240/380-460 V	Motor Vendor Lowara		
Speed 3600.0 rpm			

1SVE11F007POT/5 | Hydraulic Data & Performance Curve

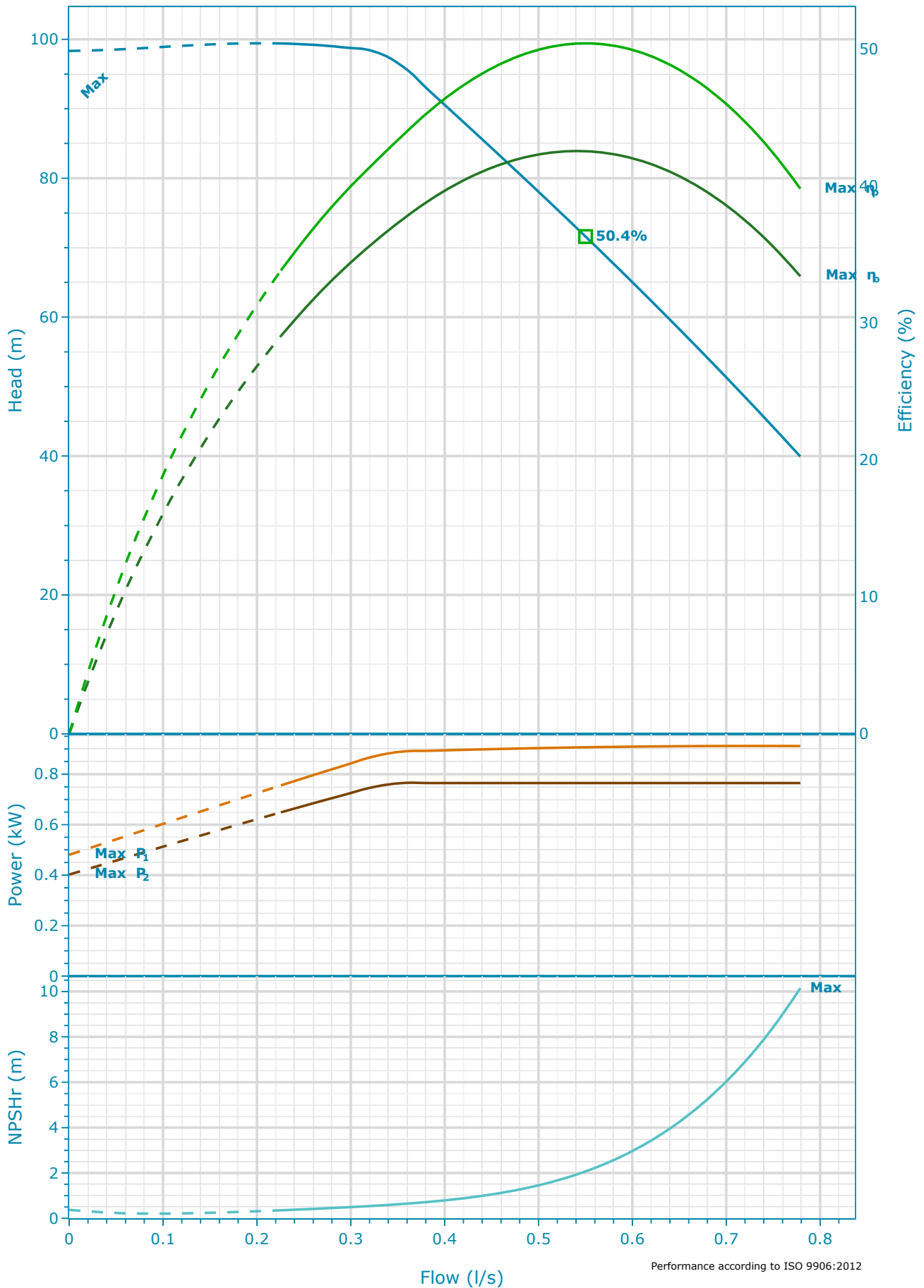

Selection

Series Standby Pumps
e-SVE No Standby Pump

Name
1SVE11...007

Stages
11

Frequency
50 Hz

Acceptance Grade
Manufacturer's Standard

System Type
Single Pump

Operating Pumps
1

Fluid and Operating Conditions

Fluid Type Density
Water 1,000 kg/m³

Fluid Temperature Dynamic Viscosity
4 °C 0.002 Pa·s

Specific Gravity Fluid Vapor Pressure
1 8.14 mbar

Atmospheric Pressure
1,013.53 mbar

Elevation
0 m

Ambient Temperature
20 °C

NPSH Available
10.27 m

Submergence
0 m

Design Curve

Rated Speed BEP
3,600 RPM 50.41 %

Min Flow BEP Flow
0.23 l/s 0.55 l/s

Max Flow BEP Head
0.78 l/s 71.6 m

H@QMin Max Operating Pressure
99.4 m 9,736.67 mbar

H@QMax Max P2
39.93 m 0.77 kW

1SVE11F007POT/5 | Dimensional Data & Drawing

1-3-5SVE (F-N)

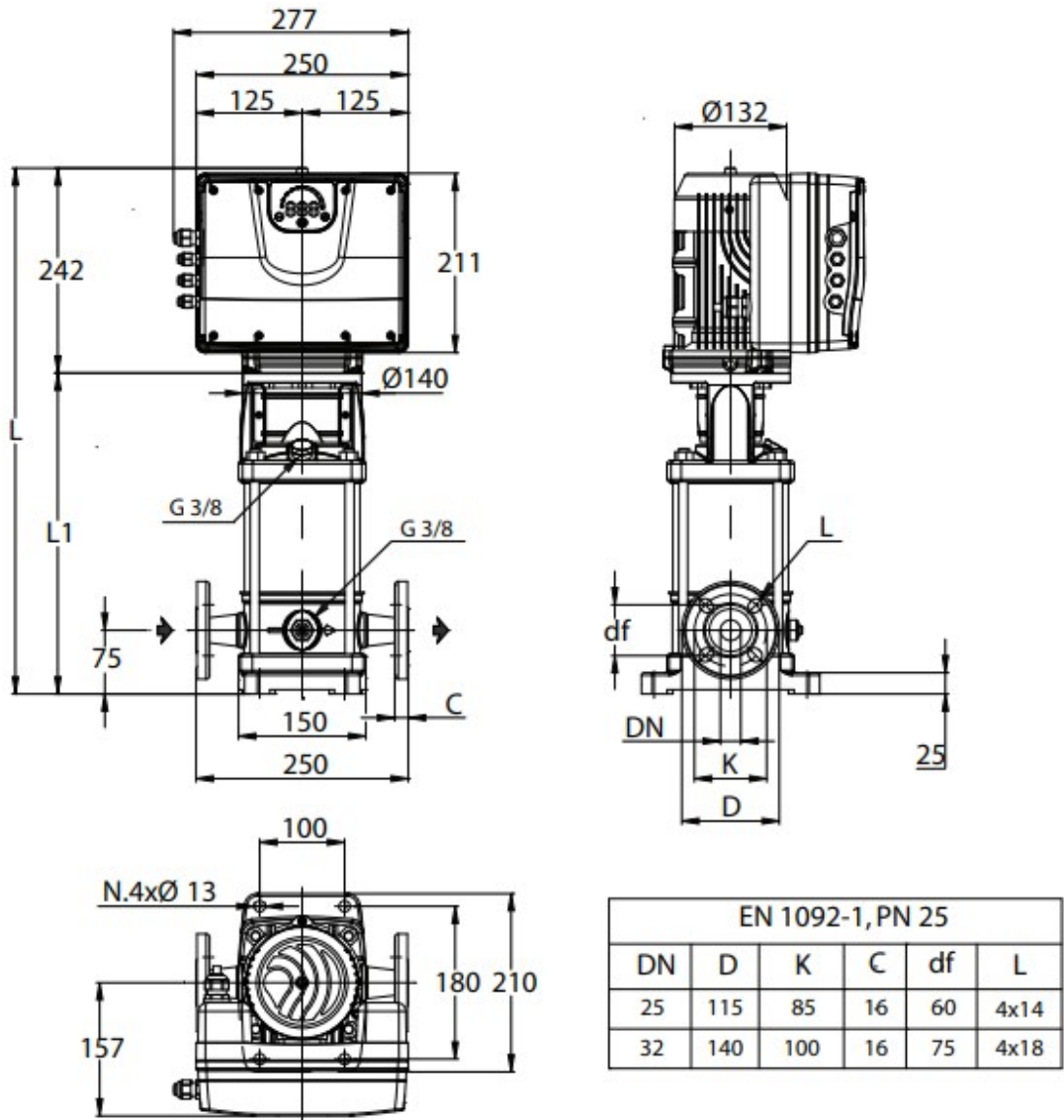

Drawing is preliminary and is subject to change.

Dimensions

D1 4 x 14	Weight (Pump) 12.4 kg
L 700 mm	Total Weight 25.5 kg
L1 458 mm	
DN 25 mm	