

MONSOON PROFESSIONAL

Installation, Operation & Maintenance Instructions

This instruction booklet is for use by the homeowner, containing installation, warranty, maintenance and safety information.



Read this manual carefully before commencing installation.

This manual covers the following products:

MONSOON PROFESSIONAL

Pt. No. 47729

**Please note images are representative only and may not portray
your model**



CONTENTS

1 PRODUCT OVERVIEW 1

2 WARNINGS 2

3 CHECKLIST 3

4 IMPORTANT FACTS - READ BEFORE COMMENCING PUMP INSTALLATION 4

5 LOCATION - GENERAL 5

6 PUMP CONNECTIONS 8

7 ELECTRICAL INSTALLATION 9

8 COMMISSIONING 12

9 MAINTENANCE 16

10 TECHNICAL SPECIFICATION 18

11 PUMP TROUBLE SHOOTING GUIDE 20

12 PRODUCT WARRANTY TERMS & CONDITIONS 25

1 PRODUCT OVERVIEW

Please read installation details carefully as they are intended to ensure this product provides long, trouble free service. Failure to install the unit in accordance with the installation instructions will lead to invalidation of the warranty.

1.1 Product Description

Electric motor-driven centrifugal pump with an automatic control system consisting of a pressure transducer, pressure vessel, temperature sensor, flow sensor and electronic control.

1.2 Application

The MONSOON PROFESSIONAL is a whole home variable speed pump, for use in interior applications with combi-boilers & pressurised hot water cylinders, supplied by a cold water storage tank. This pump can be used in systems where a neutral or positive head exists, or suction lift up to 6m. Inlet pressures to the pump must not exceed the values given in the technical specifications.

1.3 Storage

If this product is not to be installed immediately on receipt, ensure that it is stored in a dry, frost and vibration free location in its original packaging.

1.4 Environment Protection

Your appliance contains valuable materials which can be recovered or recycled.

At the end of the products' useful life, please leave it at an appropriate local civic waste collection point.

2 WARNINGS



- This pump set must not be used for any other application without the written consent of Stuart Turner Limited and in particular, must not be connected directly to the mains water supply.
- Children shall not play with the appliance.
- The motor casing can become very hot under normal operating conditions. Care must be taken to ensure it cannot be touched during operation.



- The electrical installation must be carried out in accordance with the current national electrical regulations.
- The electrical installation must be installed by a qualified person.
- RCD's/ELCB's are not recommended for use with variable speed drives/motors. If an RCD is mandatory use type B RCD's.
- For single phase sets with inverter motors the earth leakage circuit breaker must trip out when an earth fault currents with DC content (pulsating DC) occur.
- RCD's suitable for use with variable speed drives/motors are not suitable for personnel protection.
- Do not touch any electrical components for at least 5 minutes after the unit has stopped to allow any discharge to occur safely.
- Before starting work on the electrical supply ensure power supply is isolated.



- DO NOT allow the supply cord to contact hot surfaces, including the motor shell, pump body or pipework. The cord should be safely routed and secured by cable clips.
- This product does not contain any user servicable parts. Contact Stuart Turner Ltd for support.
- Any modification to this product is prohibited and additionally voids any warranty or legal rights.
- This product must be installed in accordance with the current Water Supply (Water Fittings) Regulations by a qualified person.

3 CHECKLIST

IMPORTANT: With the pump removed from its packaging check for any damage prior to installation. If any damage is found contact Stuart Turner Ltd within 24 hours of receipt.



A

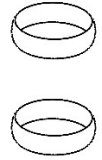

B

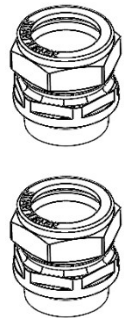

C

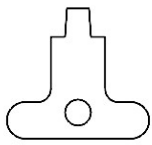

D

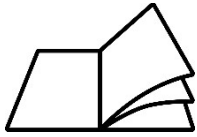

E

Note: Images for reference only and may differ from what is shown.

ITEM	DESCRIPTION	QTY	NOTES
A	Pump	1	
B	UK 28mm compression olives	2	In envelope
C	G1" inlet / outlet compression fitting and O-ring	2	1" Irish/Eire olive included per fitting
D	Vent plug tool	1	
E	Safety Data Sheet	1	See for serial no.

Your product may vary slightly from the illustration above.

4 IMPORTANT FACTS - READ BEFORE COMMENCING PUMP INSTALLATION

4.1 Water Storage Capacity

The cold-water storage capacity must be sufficient to meet the flow rates required by the pump equipment and any other water-using fittings and appliances, which may be operated simultaneously.

4.2 Water Temperature

- Maximum water temperature is 23°C.
- Minimum water temperature is 4 °C.

4.3 Pipework – General

Secure pipework: Ensure pipework to and from pump is independently supported & clipped to prevent forces being transferred to inlet and outlet branches of pump.

Flux: Solder joints must be completed and flux residues removed prior to pump installation (**flux damage will void any warranty**).



- **DO NOT** introduce solder flux to the pump or pump parts manufactured from plastic.
- **DO NOT** allow contact with oil or cellulose based paints, paint thinners or strippers, acid based descalents or aggressive cleaning agents.



- **DO NOT (except in suction lift application)** install a non-return valve, or devices which contain non-return valves, in the suction (inlet) pipework to the pump. The pump must be free to vent to the supply tank at all times.
- **DO NOT** connect this pump to the mains water supply.
- **DO NOT** use a sealant where solid matter can be released into the pump or system, such as a hemp-based sealant. Use of such a material can damage the pump and will void warranty.

4.4 Plumbing Installation Regulations

The plumbing installation must comply with the current water and building regulations.

The plumbing installation must be installed by a qualified person.

5 LOCATION - GENERAL



- **Access:** For emergencies and maintenance the pump must be easily accessible.
- **Protection:** The pump must be in a dry, frost-free area, protected from freezing, excessively high temperatures (above 40°C) and the elements.
- **Ambient temperature:** The ambient temperature must not exceed 40°C on a continuous basis.
- **Ventilation:** A 250 mm (10") air gap must be maintained around the pump, to ensure adequate air flow for pump cooling. Separate the pump from any heat source including other appliances.
- **Safety:** The motor casing can become very hot under normal operating conditions. Care must be taken to ensure it cannot be touched during operation.
- **Water retention:** Site the pump in a location where in the unlikely event of a water leak, any spillage is contained or routed to avoid electrics or areas sensitive to water damage.
- **Static inlet pressure:** Before deciding where to locate the unit, check to ensure the static inlet head between pump and the bottom of the cold-water tank (Ref Fig. 2) does not exceed the max. inlet head of 30 metres/3 bar.
- **Pipework:** For optimum performance, use 1" internal diameter pipe or 28mm external diameter tube (DN25).
- **Note:** Inlet pipework must always be greater than or equal to the outlet pipework diameter.

When the length of the inlet pipe is more than 10 meters or the suction lift at the inlet pipe is greater than 4 meters, the diameter of the inlet pipe must be larger than the diameter of the outlet.

- **Fixing:** Ensure the pump is adequately secure when installed.
- **Noise:** Care must be taken when mounting the pump so that noise is not amplified through loose panels or pipework.
- **Direction of flow:** Ensure water enters the pump via the inlet on the front of the pump and exits out of the top.
- **Isolating valves:** Separate system isolating valves (**1" or 28mm full bore; non-restrictive – not included**) must be fitted on inlet and outlet to allow ease of system service or fault diagnosis.



5.1 Cold Water Tank Installation

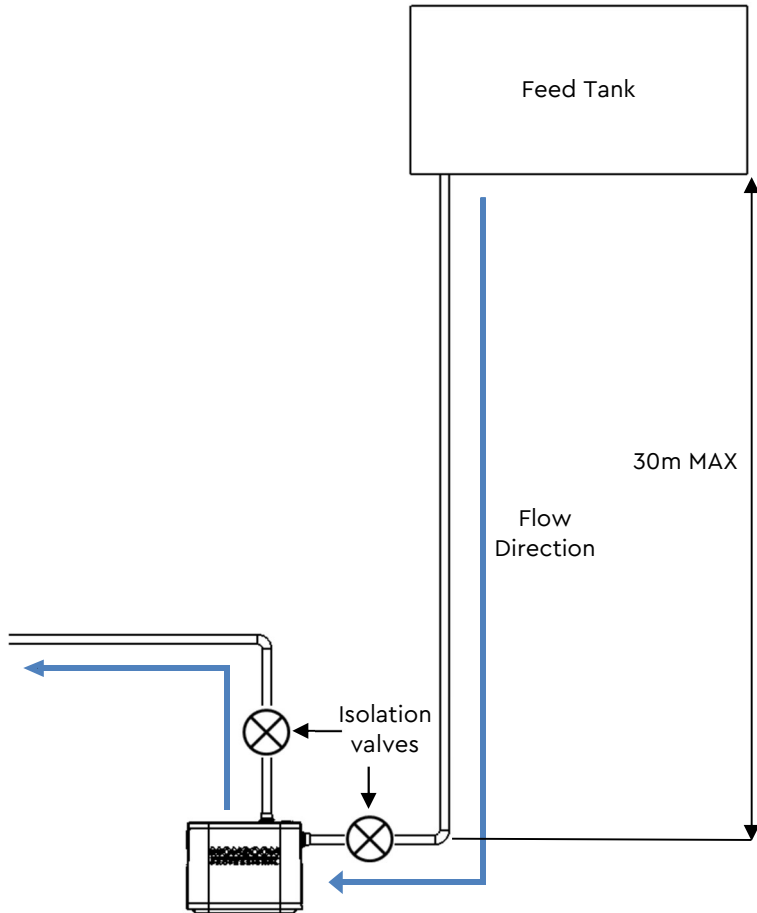

Figure 1 - Cold Water Tank Installation

- **Cold-water supply:** Must be a dedicated air-free supply via a tank. **DO NOT** connect to the directly to the mains water supply.
- **Max static inlet head:** 30m (3 bar).
- **Isolating valves:** Separate system isolating valves (**1" or 28mm full bore; non-restrictive – not included**) must be fitted on inlet and outlet to allow ease of system service or fault diagnosis.

5.2 Pump Above Water Source (Suction Lift)

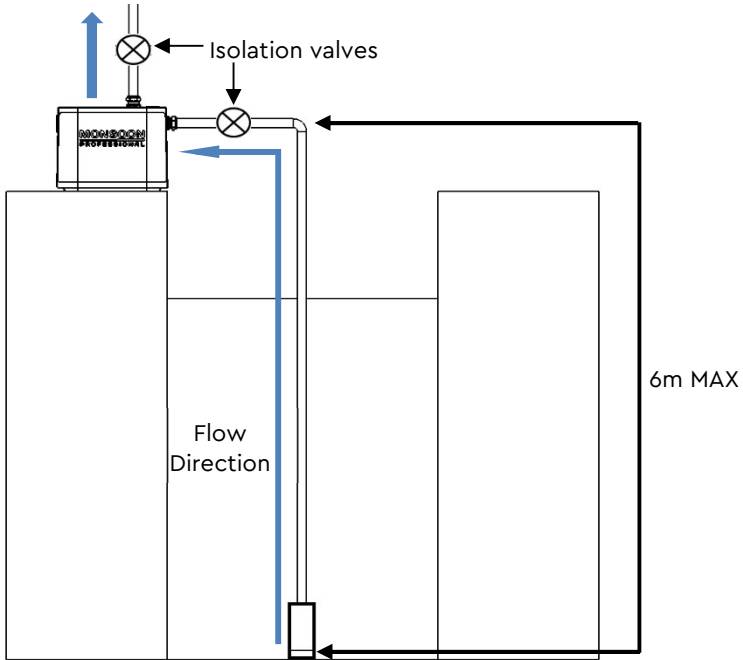

Figure 2 – Suction Lift Install

- The pump can be used for a suction lift down to a max lift height of 6 metres.
- A suction foot-valve and strainer should be used (**not included**).
- Suction pipework **must** match the pump inlet size (DN25).
- Lay suction piping over the shortest distance and ensure there is a constant rise from the water source to the pump. Any high spots will cause air pockets, reducing system efficiency.
- Ensure all joints in suction/outlet pipework are airtight. Failure to comply will result in loss of prime and pump damage.
- The intake of the foot-valve/strainer should be positioned so it cannot be blocked with debris or silt, frequently at the bottom of sumps/wells.
- **Isolating valves:** Separate system isolating valves (**1" or 28mm full bore; non-restrictive – not included**) must be fitted on inlet and outlet to allow ease of system service or fault diagnosis.
- **Entire suction pipe requires priming before use** – see section 8.1.

6 PUMP CONNECTIONS



- **Step 1 - Inlet/outlet brass compression adaptor:** Adapters must be fitted with the provided O-rings, and then installed to the inlet and outlet of the pump. The adapters must be screwed in until they bottom out at approximately 30N/m; there must be no gap between the sealing face of the pump and the external lip of the adaptor – see figure 3.

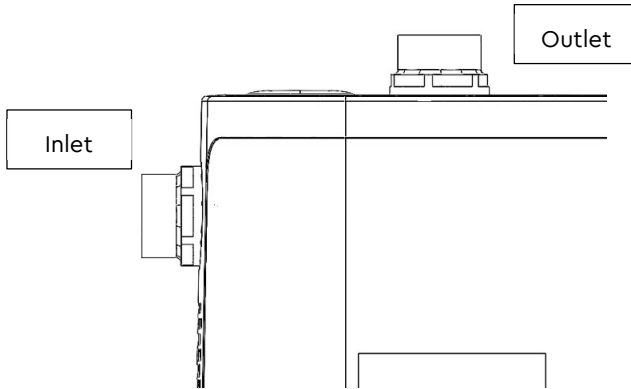

Figure 3 – Adaptor Install Step 1

- **Step 2 : Inlet/outlet compression adaptor:** Tighten the compression nut to 40N/m for installation of either UK 28mm olive (packed separately) or 1" Irish compression olives supplied in situ in the adaptor – see figure 4. **Ensure that a second wrench is used to counter torque the adaptor already installed per step 1.**

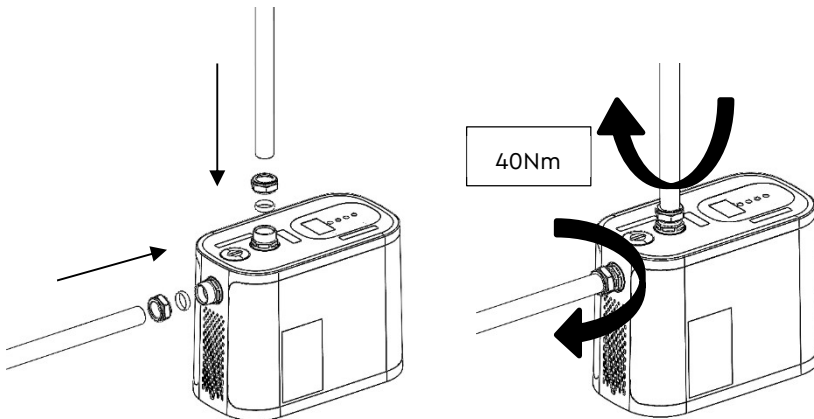

Figure 5 – Adaptor Install Step 2

7 ELECTRICAL INSTALLATION



- Before starting work on the electrical supply ensure the power supply is isolated.
- **Regulations:** The electrical installation must be carried out in accordance with the current national electrical regulations and installed by a qualified person.
- **Connections:** The pump must be permanently connected to the fixed wiring of the mains supply, using the factory fitted supply cord. This **MUST** be via a double pole switched fused spur off the ring main and **NOT** connected to the boiler or the immersion heater circuits. **Do NOT use a generator as a power source.**
- **DO NOT** touch the electrical wire conductors from the power cable for at least 5 minutes after the unit has stopped, to allow any discharge to occur safely.
- **DO NOT** allow the supply cord to contact hot surfaces, including the motor shell, pump body or pipework. The cord should be safely routed and secured by cable clips.
- **RCD's/ELCB's** are not recommended for use with variable speed drives/motors. If an RCD is mandatory use type B RCD's.
- **RCD's** suitable for use with variable speed drives/motors are not suitable for personnel protection.
- **Earthing:** This appliance must be earthed via the supply cord.
- **Pipework:** Copper or metallic pipework must have supplementary earth bonding where the earth continuity has been broken i.e. by plastic components (ref Fig 5),
- **Additional earthing:** Certain installations may require additional earthing arrangements such as equipotential bonding. Reference should be made to the relevant regulations concerning this subject to ensure compliance (ref Fig 5).
- **Adjacent pipes:** Adjacent suction and delivery pipes should be fitted with earthing clamps in accordance with current regulations.
- **For single phase sets** with inverter motors the earth leakage circuit breaker must trip out when an earth fault currents with DC content (pulsating DC) occur.

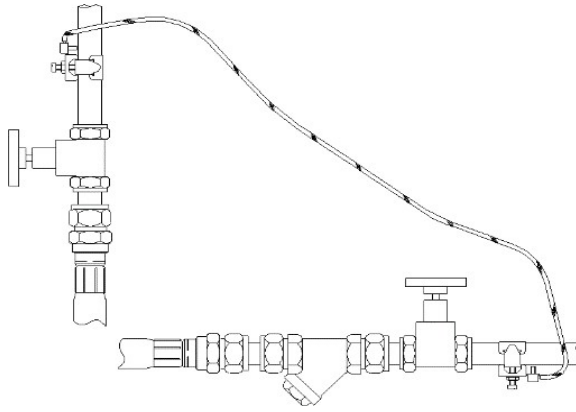

Figure 5 - Earth Continuity

7.1 Wiring of Connection Unit



WARNING: This appliance must be earthed.

The wires in the mains lead (supply cord) are coloured in accordance with the following code:

- Green and Yellow: Earth
- Blue: Neutral
- Brown: Live

As the colours of the wires in the mains lead of this appliance may not correspond with the coloured markings identifying the terminals in your connection unit proceed as follows:



- The wire which is coloured green and yellow must be connected to the terminal in the connection unit which is marked with the letter E or by the earth symbol:  or coloured green or green and yellow.
- The wire which is coloured blue must be connected to the terminal which is marked with the letter N or coloured black.
- The wire which is coloured brown must be connected to the terminal which is marked with the letter L or coloured red.

7.2 Fuses

The following fuse size should be used with the appropriate pump.

Model	Fuse Rating
MONSOON PROFESSIONAL - 47729	10A

8 COMMISSIONING



System Flushing

The pipework system should be flushed prior to the pump being connected to ensure any contaminants/chemical residues and foreign bodies are removed from the system.

Water Supply: Always ensure that water storage capacity is adequate to meet the demand. Ensure the pump chamber is full of water before starting the pump. Failure to do this could result in damage. The pump must be primed as described in priming section below to prevent dry running. **DO NOT** dry run the pump. The volume ratio of solid impurities in the medium should not exceed 0.1%, and the particle size should not exceed 0.2mm diameter.

8.1 Priming



Once connected to water supply, the pump must be primed (filled with water), and air vented before from the pump before operation.

- Unscrew the vent plug using the tool provided or flathead screwdriver and fill with water, air will automatically vent out of the pump.
- Re-seal vent plug, ensuring o-ring is seated correctly on plug underside, nipping tight using the tool or flat head screwdriver. The pump is now ready to start.
- **See section 9.2** for maintenance information for the integrated strainer/vent plug.
- **For suction lift application, ensure entire suction pipe is vented of air by priming with water per above.**

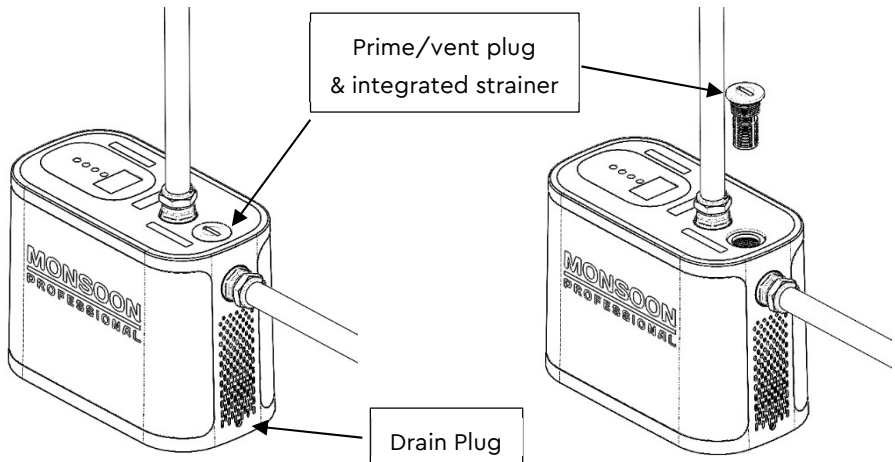

Figure 6 – Prime/vent/strainer and drain plug

8.2 Starting

Never operate pump with inlet and/or outlet isolating valves in the closed position. Damage will occur!

- a. Ensure all outlets are closed, turn power supply 'on' - pump will start and pressurise the system then stop. The software version will be displayed on initial power up in the format UX.X.
- b. Open and close all outlets in turn associated with the pump (including WC systems) allowing water to flow from each outlet until all air is purged. As each outlet is opened and closed, the pump will start and stop respectively.
- c. Note: After closing the outlet there will be a small time-delay before the pump stops, which is normal.
- d. Any tap or control valve within the system when opened and closed will now turn the pump on/off. Providing this is the case the system is now operating correctly.
- e. Carefully check pump and pipework for leaks whilst pump running and stationary before leaving the installation unattended.

8.3 Display panel diagram

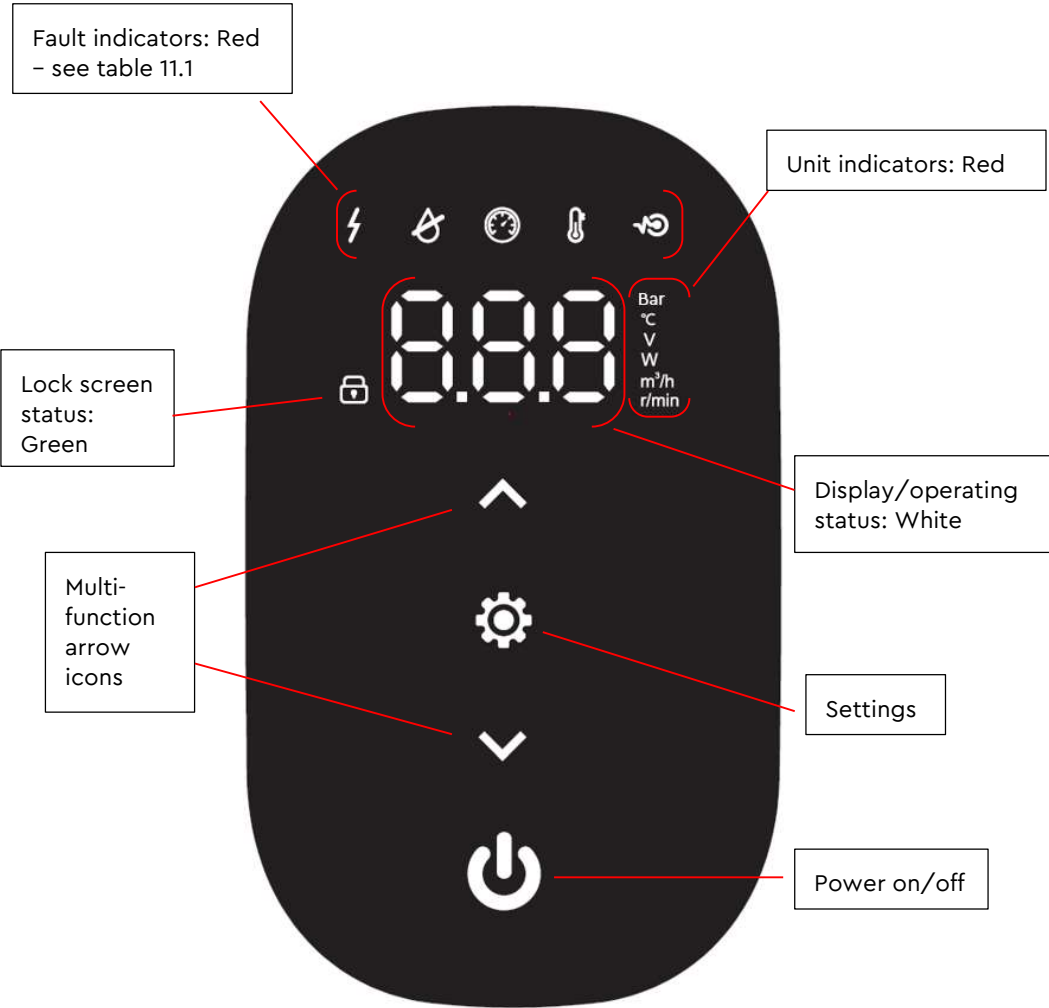

8.4 How to use the control panel

Startup

- a. Ensure the pump has mains power. The pump will power up and show all indicator lights for 2 seconds.

Current Software Version

- b. Software version will then show for 2 seconds, in format UX.X.

Setting outlet pressure

- c. Increase/decrease set pressure to required setting for installation outlet head, in 0.1 bar increments using the up/down arrows. **Default is 3 bar. Maximum is 4.2 bar, minimum is 1 bar.**

Pump operating status indicators

- d. Pressing the settings button, will cycle through the display of different pump parameters:
 - Current outlet pressure, prefix "H" (bar)
 - Set outlet pressure, prefix "D" (bar)
 - Water temperature (°C)
 - Power consumption (W)
 - Voltage (V)
 - Flow (m³/h)
 - Motor RPM (r/min)
 - Software version, format UX.X

Stopping/starting the pump

- e. Press the power icon to start and stop pump operation.

Automatic screen lock

- f. After 60 seconds of inactivity, all indicator lights will turn off, and the lock screen indicator will flash green.

Unlocking the screen

- g. Hold down up & down arrows simultaneously for 3 seconds.
- h. The display will illuminate, and lock screen icon will disappear.

Default Reset

- i. With the pump off, press and hold the settings icon & down icon simultaneously for 3 seconds to reset pump to default settings 888 will appear, the pump is now reset.

Technical Support: Phone the Stuart Turner TechAssist team on +44 (0) 800 31 969 80.

9 MAINTENANCE



No user serviceable parts inside.

There are no user serviceable parts available for the pump.

Disconnect electrical supply before working on the pump.



Turn off water supplies to the pump and release pressure by opening water outlets before attempting maintenance/disconnection from water inlet/outlet.

9.1 Pressure Vessel Pre-Charge

The vessel pre-charge for the pump is set to 1.6 bar. This can be re-charged using the vessel access cap at the front of the product.

Opening the cap will allow provide access to the vessel Shraeder valve and any compatible pump can be used to re-charge the vessel pressure – see figure 8 below.

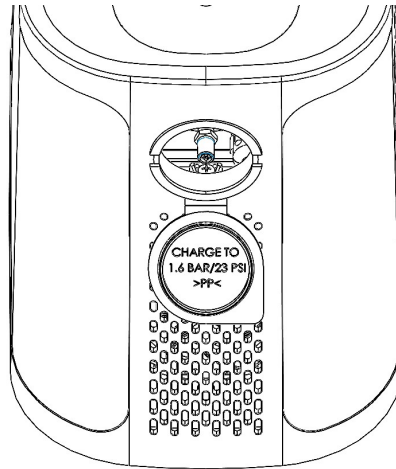
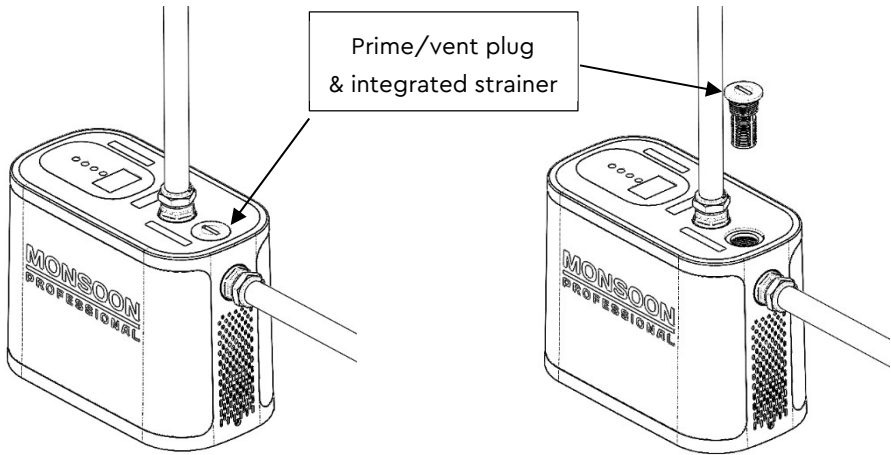

Figure 7 – Vessel Re-charging

9.2 Vent Plug Integrated Inlet Strainer

If there is a loss in flow or pressure performance, one potential cause is blockage of the inlet strainer.

1. Isolate the inlet/outlet water connections & pump power supply.
2. Remove the plug using the tool provided or a flat head screwdriver and remove/wash any debris using cold water.
3. Refit the plug ensuring the O-ring is seated correctly on the plug underside, nipping tight using the tool or flat head screwdriver.
4. Resume water and power supply to the pump, and check for any leak from the plug when running.



9.3 Cleaners, Disinfectants and Descalents



Acid-based descalers and aggressive cleaning agents must not come into contact with the pump. The pump must be removed from the system prior to the use of these products. The system should be flushed to remove all chemicals before the pump is reconnected.

If in any doubt as to the suitability of the chemical solutions, please contact our TechAssist helpline on +44 (0) 800 31 969 80.

When the ambient temperature is lower than 4°C and the pump is not in use, the pump chamber should be drained of water to protect internal components.

10 TECHNICAL SPECIFICATION

General	Warranty	5 years (subject to conditions)
	Conformity certification	UKCA CE WRAS
Features	Pump type	Variable Speed Centrifugal Multistage
	Pump control	Pressure Transducer/ Flow sensor/Pressure Vessel
	Electrical failure detection	●
	Motor failure detection	●
	Dry run protection	●
	Sensor failure detection	●
	Low/high fluid temperature detection	●
	Water anti-freezing protection	●
	Ambient over temperature detection	●
	Fluid leakage detection	●
	Prime/vent/drain plug	●
	Integrated inlet strainer	●
	Typical noise*	55 dB(A)
Performance	Maximum head - closed valve	4.2 bar/ 43 metres
	Dynamic Performance @ 40 l/min**	2.8 bar/ 28 metres
	Dynamic Performance @ 60 l/min**	1.6 bar /16 metres
	Maximum flow**	78 l/min
	Maximum static inlet pressure	3 bar/31 metres
	Maximum working pressure	800 kPa (8 bar)
	Max set pressure	4.2 bar
	Min set pressure	1 bar
	Maximum ambient air temperature	40°C (Continuous)
	Min / Max water temperature	Min 4°C / Max 23°C
	Max suction lift***	6 metres
Materials	Pump body	PA66 GF30 (Glass Re-enforced Polymer)
	Pump impeller	PPO GF30 (Glass Re-enforced Polymer)
	Mechanical pump seal	NBR / Silicon carbide/ Alumina ceramic/SS304
Connections	Pump connections	1" F (DN25)
Motor	Type	Permanent magnet variable frequency
	Duty rating	Continuous (S1)
Electrical	Power supply (Vac/Ph/Hz)	220-240V a.c. / 1 / 50Hz
	Power consumption - P1	600 Watts
	Current - full load	2.8 Amps
	Fuse rating	10 Amps
	Power cable length	1.5 metres
Physical	Enclosure protection	IP55
	Length	345 mm
	Width	188 mm
	Height - excluding fittings	273 mm
	Weight - excluding fittings	8.04 kg

NOTES

*Noise: The equivalent continuous A-weighted sound pressure level, 1 metre from the pump should not exceed 55dB(A).

** Performance: Tested in conditions with minimal losses. Installed performance may vary depending on install conditions.





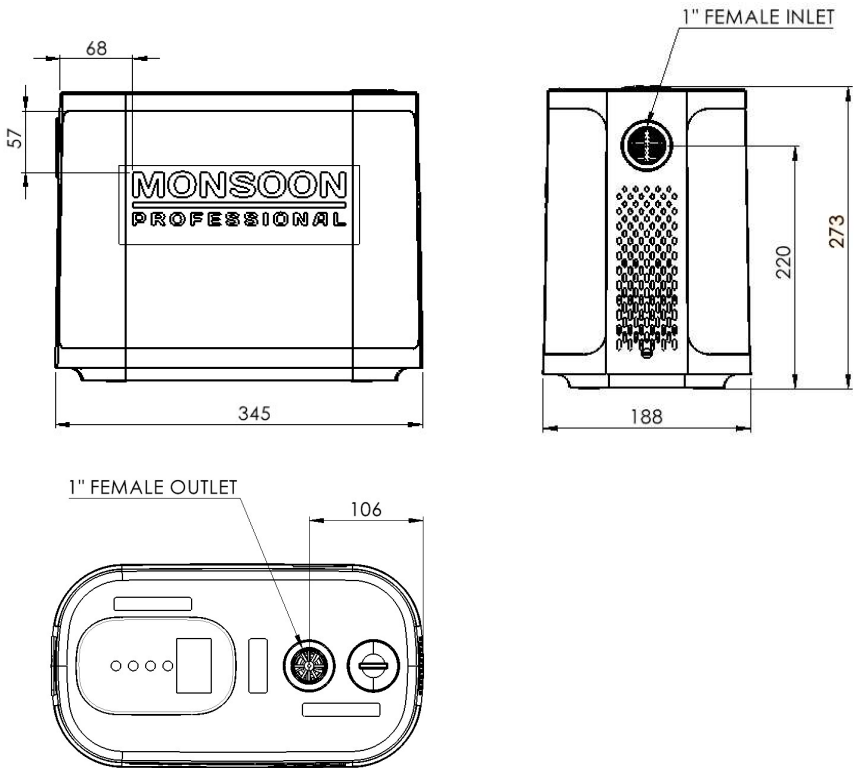



*** Suction lift of up to 6 metres can be achieved if a foot valve and strainer is used.

DIMENSIONS



11 PUMP TROUBLE SHOOTING GUIDE

11.1 Fault Codes

Displayed Error	Error Symbol	Error Type	Solution
E01		Hardware overcurrent	Turn pump off/on. If error remains contact Stuart Turner
E02		Software overcurrent	
E03		Current calibration error	Turn pump off/on. If error remains contact Stuart Turner
E04		Supply voltage too low	Turn pump off/on. If error remains contact power provider
E05		Supply voltage too high	
E06		Missing motor phase	Turn pump off/on. If error remains contact Stuart Turner
E07		Pump blocked	Turn pump off/on. If error remains contact Stuart Turner
E08	E08 display	Communication error	Turn pump off/on. If error remains contact Stuart Turner
E10		Water shortage	Check inlet isolation valve is open.
E11		Dry run protection	Check inlet strainer for blockage – see 9.2 Check feed tank is not empty. Vent pump of air via vent plug.
E12		Overload	Turn pump off/on. If error remains contact Stuart Turner
E13		Pressure sensor fault	Turn pump off/on. If error remains contact Stuart Turner
E14		Temperature sensor fault	Turn pump off/on. If error remains contact Stuart Turner
E15	E15 display	Flow sensor fault	Turn pump off/on. If error remains contact Stuart Turner
E18	E18 display	High ambient overheat	Ensure ambient air temperature is not above 40°C.
E24		High water temperature warning	Ensure inlet water temperature is not above 65°C.
E25		Low water temperature warning	Ensure inlet water temperature is not below 5°C.
E26	E26 display	Leakage warning	Check all accessible joints, seals and fittings in the system rectify as necessary if leaking.

11.2 General Guide

Symptoms	Probable Cause	Recommended Action
Pump will not start	Electrical supply – see errors E01, E02, E03, E04, E05	Check power supply
		Check power supply cable
		Check fuse
		Check circuit breaker is set
		Check wiring connections
	Pump seized – see error E07	Contact Stuart Turner
	Motor is faulty – see error E06, E12	Contact Stuart Turner
Control panel damaged – see error E08	Contact Stuart Turner	
Pump water pressure Insufficient	Pressure setting incorrect	Ensure set pressure is correct
	Strainer blockage	Ensure strainer is clear – see 9.2
	Inlet pipe diameter too small	Check diameter of pipe
	Blockage in inlet/outlet pipe	Check pipework for blockage/restriction.
Pump flow Insufficient	Strainer blockage	Ensure strainer is clear – see 9.2
	Installation max lift head not exceeded	Ensure max lift head is not exceeded**
	Impeller damaged	Contact Stuart Turner
No water being discharged when pump is running	Pump needs priming	Prime & vent pump
	Water supply failed – see errors E10/E11	Check water supply
	Pump outlet check valve stuck closed	Contact Stuart Turner
	Inlet pipework not air tight	Check for leaks on inlet pipes
	Impeller damaged	Contact Stuart Turner

Symptoms	Probable Cause	Recommended Action
Pump runs on with outlets closed	Leak in system – see error E26	Check accessible system pipe joints and rectify as necessary
Pump cycles (hunts) on/off frequently	Check valve faulty	Run at full flow to try and flush away debris. Remove, clean or replace non-return valve
	Pressure vessel charge low	Recharge vessel to specification
	Pressure vessel damaged	Contact Stuart Turner
	Leak in system – see error E26	Check all accessible joints, seals and fittings in the system rectify as necessary.
Excessive vibration from pump	Pump not on a stable & flat platform	Ensure pump is sited on a flat stable surface
	Bearing damaged	Contact Stuart Turner
	Impeller damaged	Contact Stuart Turner
Pump is noisy	Water inlet pipe is too small	Check inlet pipe size
	Bearing damaged	Contact Stuart Turner
	Impeller damaged	Contact Stuart Turner
Pump leaks see error E26	Pipe work not fitted correctly	Ensure all pipework to the pump is secured sufficiently
	Damaged mechanical seal in pump	Contact Stuart Turner

11.3 Protection Functionalities

11.3.1 Dry Run Protection

The pump software will detect dry running caused by water starvation. Should the pump run out of water it will stop as part of a 'protective logic sequence'.

The fault should be rectified before re-starting the pump. Check that there is sufficient water supply to the pump and ensure that all outlets are closed

– **see error codes E10 & E11.**

11.3.2 Protective Logic Sequence

If water starvation occurs and the power supply to the pump remains uninterrupted, the pump controller will perform the following protective sequence.

1. If the pump detects water starvation, it will stop operation.
2. The pump will remain in the off condition for a period of 30 minutes.
3. The pump will then re-start and if the water starvation condition remains present, the pump will stop operation.
4. The pump will remain in the off condition for a period of 60 minutes.
5. The pump will then re-start and if the water starvation condition remains present, the pump will stop operation.
6. The pump will remain in the off condition for a period of 120 minutes.
7. The pump will then re-start and if the water starvation condition remains present, the pump will stop operation, with the off-operation time doubling from previous.

If the pump fails to operate normally after three attempts, then please consult the TechAssist team on +44 (0) 800 31 969 80.

11.3.3 Water Overheating Function

If the water temperature detected is above 65°C, the pump will shut down and the temperature warning indicator will illuminate. When the pump detects the water temperature has cooled to 60°C the temperature warning indicator will turn off and the pump can resume operation - **see error E24.**

11.3.4 Water Anti Freezing Function

If the water temperature detected is below 5°C, the pump will run for 5 minutes, and the temperature warning indicator will turn on. After 10 minutes of running the temperature warning indicator will turn off – **see error E25.**

11.3.5 Water Leakage Warning

If a very low flow or pressure drop is detected **error code E26 will appear** – see trouble shooting guide for fault rectification.

11.3.6 Anti Seize Function

To help prevent seizure of the internal mechanical seal, when the pump has not been run for 72 hours it will run for 10s – **for this protection functionality the pump requires a constant power supply.**

11.3.7 Power Loss Memory Function

In the event of power loss to the pump, after power is restored the pump will return to its previous operating settings automatically. If the pump was running prior to the power loss, it will continue operation with power resumption.

12 PRODUCT WARRANTY TERMS & CONDITIONS

Congratulations on purchasing a Stuart Turner product

We are confident this product will provide many years of trouble free service as all our products are manufactured to the very highest standard.

All Stuart Turner MONSOON PROFESSIONAL pumps are warranted to be free from defects in materials or workmanship for up to 12 months from date of purchase within the UK, and 24 months for pumps purchased within the Republic of Ireland.

The pump must be registered within 12 months of purchase to qualify for the extended warranty.

If registered without uploading a valid proof of purchase, the warranty is extended to 5 years from the date of manufacture. If registered with a valid proof of purchase, the warranty is extended to 5 years from the date of purchase.

Within the warranty period we will repair, free of charge, any defects in the product resulting from faults in material or workmanship, repairing or exchanging the whole unit as we may reasonably decide.

Please register your product warranty here:

<https://www.stuart-turner.co.uk/warranty>

Warranty Exclusions

Not covered by this warranty: Damage arising from incorrect installation, improper use, unauthorised repair, normal wear and tear and defects which have a negligible effect on the value or operation of the pump.

This warranty is in addition to your statutory rights as a consumer. If you are in any doubt as to these rights, please contact your local Trading Standards Department.

Warranty Claim Procedure

In the event of a claim please telephone 'TechAssist' on **+44 (0) 800 31 969 80** or email us at **techassist@stuart-turner.co.uk**

In the event of a claim within the terms of this warranty policy, your receipt or 'proof of purchase' provided during registration will be reviewed.

You should obtain appropriate insurance cover for any loss or damage which is not covered by Stuart Turner Ltd in this provision.

Please make a note for your own reference:

PRODUCT MODEL	SERIAL NO.	DATE PURCHASED
---------------	------------	----------------



UK DECLARATION OF CONFORMITY
47729 MONSOON PROFESSIONAL

Supply of Machinery Regulation - 2008

EN ISO 12100:2010, EN 809:1998+A1:2009/ AC:2010

Electrical Equipment Regulation - 2006

EN 60335-1: 2012 +A11: 2014 +A13: 2017 + A1: 2019 + A14:
2019 +A2: 2019 + A15: 2021
EN 60335-2-41: 2021 + A11: 2021

RoHS Regulation - 2012

RoHS in EEE Regulation 2012
RoHS in EEE Regulation (Amendment) 2021

WEEE Directive-2013

EMC Regulation - 2016

EN IEC 55014-1: 2021
EN IEC 55014-2: 2021
EN IEC 61000-3-2: 2019/A1:2021
EN 61000-3-3: 2013/A2:2021

EMF Regulations - 2012

EN 62233: 2008 + AC: 2008

IT IS HEREBY CERTIFIED THAT THE STUART TURNER PUMP: 47729 COMPLIES WITH THE ESSENTIAL REQUIREMENTS OF THE ABOVE STATUTORY REGULATIONS AND EU DIRECTIVES

STUART TURNER LTD
HENLEY-ON-THAMES, OXFORDSHIRE
RG9 2AD, ENGLAND
WEBSITE: www.stuart-turner.co.uk
RESPONSIBLE PERSON AND MANUFACTURER

Signed *Stuart Savill*

Stuart Savill, Head of Engineering
Stuart Turner Ltd

Stuart Turner is an approved company to BS EN 9001:2015



EU DECLARATION OF CONFORMITY
47729 MONSOON PROFESSIONAL

Machinery Directive - 2006/42/EC

EN ISO 12100:2010, EN 809:1998+a1:2009/AC:2010

Low Voltage Directive - 2014/35/EC

EN 60335-1: 2012 +A11: 2014 +A13: 2017 + A1: 2019 + A14:
2019 +A2: 2019 + A15: 2021
EN 60335-2-41: 2021 + A11: 2021

RoHS Directive - 2011

RoHS Directive 2011/65/EU
And Amendment 2015/863

WEEE Directive - 2012/19/EU

EMC Directive - 2014/30/EU

EN IEC 55014-1: 2021
EN IEC 55014-2: 2021
EN IEC 61000-3-2: 2019/A1:2021
EN 61000-3-3: 2013/A2:2021

EMF Directive - 1999/519/EC

EN 62233: 2008 + AC: 2008

IT IS HEREBY CERTIFIED THAT THE STUART TURNER PUMP: 47729 COMPLIES WITH THE ESSENTIAL REQUIREMENTS OF THE ABOVE STATUTORY REGULATIONS AND EU DIRECTIVES

STUART TURNER LTD
HENLEY-ON-THAMES, OXFORDSHIRE
RG9 2AD, ENGLAND
WEBSITE: www.stuart-turner.co.uk
RESPONSIBLE PERSON AND MANUFACTURER

EU AUTHORISED REPRESENTATIVE
ARC (AUTHORISED REP COMPLIANCE)
GROUND FLOOR, 71 LOWER BAGGOT
STREET, DUBLIN DO2 P593, IRELAND
www.authorisedrepcompliance.co.uk

Signed *Stuart Savill*

Stuart Savill, Head of Engineering
Stuart Turner Ltd

Stuart Turner is an approved company to BS EN 9001:2015



Stuart Turner Ltd, Henley-on-Thames, Oxfordshire RG9 2AD ENGLAND Tel: +44 (0) 1491 572655
info@stuart-turner.co.uk | www.stuart-turner.co.uk