

# Operating instructions

## Diaphragm Motor-Driven Metering Pump Sigma/ 1 Control Type S1Cb

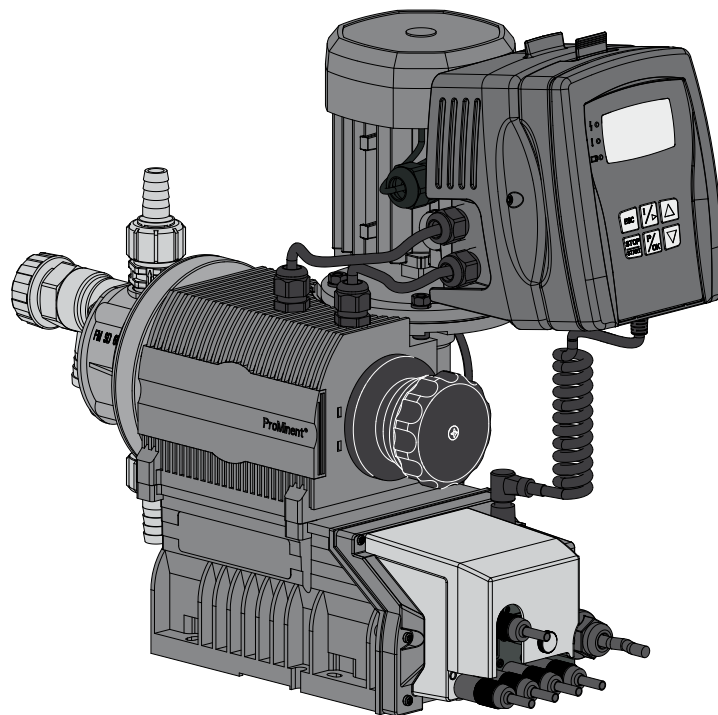

Please carefully read these operating instructions before use! · Do not discard!  
The operator shall be liable for any damage caused by installation or operating errors!  
Technical changes reserved.

ProMinent Dosiertechnik GmbH  
Im Schuhmachergewann 5-11  
69123 Heidelberg  
Germany  
Telephone: +49 6221 842-0  
Fax: +49 6221 842-617  
email: [info@prominent.com](mailto:info@prominent.com)  
Internet: [www.prominent.com](http://www.prominent.com)

985451, 1, en\_GB

## Supplementary information



Fig. 1: Please read!

Read the following supplementary information in its entirety! Should you already know this information, you have an even greater need of the Operating Instructions.

The following are highlighted separately in the document:

■ Enumerated lists

➔ Operation guidelines

⇒ Outcome of the operation guidelines

- see (reference)

**Information**

*This provides important information relating to the correct operation of the device or is intended to make your work easier.*

**Safety notes**

Safety notes are identified by pictograms - see Safety Chapter.

**State the identity code and serial number**

Please state identity code and serial number, which you can find on the nameplate when you contact us or order spare parts. This enables the device type and material versions to be clearly identified.

**General non-discriminatory approach**

In order to make it easier to read, this document uses the male form in grammatical structures but with an implied neutral sense. It is aimed equally at both men and women. We kindly ask female readers for their understanding in this simplification of the text.

# Table of contents

<b>1</b>	<b>Identity code</b> .....	<b>6</b>
<b>2</b>	<b>Safety chapter</b> .....	<b>9</b>
<b>3</b>	<b>Storage, transport and unpacking</b> .....	<b>13</b>
<b>4</b>	<b>Overview of equipment and control elements</b> .....	<b>15</b>
	4.1 Key functions.....	17
	4.2 LCD screen identifiers.....	17
<b>5</b>	<b>Functional description</b> .....	<b>20</b>
	5.1 Drive unit.....	20
	5.2 Liquid end.....	21
	5.3 Integral bleed valve.....	22
	5.4 Multi-layer safety diaphragm.....	23
	5.5 Operating modes.....	24
	5.6 Functions.....	24
	5.7 Options.....	25
	5.8 Function and fault indicator.....	26
	5.9 LCD screen.....	26
	5.10 LED displays.....	26
	5.11 Hierarchy of operating modes, functions and fault statuses.....	26
<b>6</b>	<b>Assembly</b> .....	<b>28</b>
<b>7</b>	<b>Installation</b> .....	<b>31</b>
	7.1 Installation, hydraulic.....	31
	7.2 Installation, electrical.....	34
	7.2.1 Control connectors.....	35
	7.2.2 HMI operating unit.....	41
	7.2.3 Pump, power supply.....	42
	7.2.4 Other units.....	43
<b>8</b>	<b>Set-up</b> .....	<b>44</b>
	8.1 Basic principles of control adjustment.....	44
	8.2 Checking adjustable values / error messages.....	44
	8.3 Changing to adjustment mode.....	45
	8.4 Selecting the operating mode (Menu "Mode").....	46
	8.5 Operating mode settings (menu "Settings").....	46
	8.5.1 "Manual" operating mode settings.....	47
	8.5.2 "Batch" mode settings .....	47
	8.5.3 "Contact" operating mode settings.....	48
	8.5.4 "Analog" operating mode settings.....	51
	8.6 Programmable function settings ("Settings" menu ).....	54
	8.6.1 Settings for the "Auxiliary frequency" function (AUX menu).....	54
	8.6.2 Settings for the "Calibrate" function (CALIBRATE menu) ..	55
	8.6.3 Settings for the "Metering" function (DOSING menu).....	56
	8.6.4 Settings for the "Dosing monitor" function (DOSING MONITOR menu).....	57
	8.6.5 Settings for the "Relay" function (RELAY menu).....	57
	8.6.6 Settings for the "Analog output" function (ANALOG OUTPUT menu).....	59
	8.6.7 Settings for the "Diaphragm break" function (DIAPHRAGM BREAK menu).....	59
	8.6.8 Settings in the "System" menu" (SYSTEM menu).....	60
	8.7 Service (SERVICE menu).....	60
	8.7.1 Clear counters (CLEAR COUNTERS menu).....	60
	8.7.2 Adjusting the Display (DISPLAY menu).....	61
	8.7.3 HMI logout.....	61

8.7.4 Security (SECURITY menu).....	62
8.8 Information about the pump (INFORMATION menu).....	63
8.9 Set language (LANGUAGE menu).....	63
<b>9 Operation.....</b>	<b>64</b>
9.1 Manual.....	64
9.2 Remote operation.....	66
<b>10 Maintenance.....</b>	<b>67</b>
<b>11 Repairs.....</b>	<b>69</b>
11.1 Cleaning valves.....	69
11.2 Replacing the metering diaphragm.....	71
<b>12 Troubleshooting.....</b>	<b>75</b>
12.1 Faults without a fault alert.....	75
12.2 Fault alerts.....	75
12.3 Warning Alerts.....	76
12.4 All Other Faults.....	77
<b>13 Decommissioning.....</b>	<b>78</b>
<b>14 Technical data.....</b>	<b>80</b>
14.1 Performance data.....	80
14.2 Viscosity.....	81
14.3 Shipping weight.....	81
14.4 Wetted materials.....	81
14.5 Ambient conditions.....	81
14.5.1 Ambient temperatures.....	81
14.5.2 Media temperatures.....	82
14.5.3 Air humidity.....	82
14.5.4 Enclosure rating and safety requirements.....	82
14.6 Electrical connection.....	82
14.7 Diaphragm rupture sensor.....	83
14.8 Relay.....	83
14.9 Sound pressure level.....	83
<b>15 Motor data sheets.....</b>	<b>84</b>
<b>16 Dimension sheets.....</b>	<b>85</b>
<b>17 Exploded view drawings.....</b>	<b>87</b>
17.1 Exploded drawings Sigma/ 1.....	87
<b>18 Ordering Information.....</b>	<b>93</b>
<b>19 Diagrams for adjusting the capacity.....</b>	<b>94</b>
<b>20 EC Declaration of Conformity.....</b>	<b>95</b>
<b>21 Operating / adjustment overview.....</b>	<b>96</b>
<b>22 Continuous displays.....</b>	<b>97</b>
<b>23 Index.....</b>	<b>99</b>

# 1 Identity code

## S1Cb Sigma 1, Control Type, Version b

### Product range

S1Cb

#### Power end type

H Main power end, diaphragm

Type	Performance	
	bar	l/h
12017	10*	20
12035	10*	42
10050	10	50
10022	10	26
10044	10	53
07065	7	65
07042	7	50
04084	4	101
04120	4	120

#### Material dosing head

PV PVDF

SS Stainless steel

#### Seal material

T PTFE

#### Displacement

S Multi-layer safety diaphragm with optical break indicator

A Multi-layer safety diaphragm with rupture signalling by electrical signal

#### Dosing head version

0 without bleed valve, without valve springs

1 without bleed valve, with valve springs

2 with bleed valve, FPM, without valve springs\*\*\*

3 with bleed valve, FPM, with valve springs\*\*\*

8 with bleed valve, EPDM, without valve springs\*\*\*

9 with bleed valve, EPDM, with valve springs\*\*\*

#### Hydraulic connector

0 Standard threaded connector (in line with technical data)

1 Union nut and PVC insert

2 Union nut and PP insert

3 Union nut and PVDF insert

4 Union nut and SS insert

7 Union nut and PVDF tube nozzle

8 Union nut and SS tube nozzle

9 Union nut and SS welding sleeve

## S1Cb Sigma 1, Control Type, Version b

Design	
0	With ProMinent® Logo
1	without ProMinent® logo
F	Physiological safety declaration
Electric power supply	
U	1 ph, 100-230 V ± 10 %, 50/60 Hz
Cable and plug	
A	2 m European
B	2 m Swiss
C	2 m Australian
D	2 m USA
Relay	
0	No relay
1	Fault indicating relay (230V - 8A)
3	Fault indicating relay + pacing relay (24V - 100mA)
8	0/4-20 mA analog output + fault indicating -/ pacing relay (24V - 100mA)
Control version	
0	Manual + external contact with pulse control
1	Manual + external contact with pulse control + analog + dosing profiles
5	as 1 + timer
6	as 1 + PROFIBUS®-DP interface (M12 plug)
7	As 1 + CANopen **
Overload switch-off	
0	without overload switch-off
1	with overload switch-off - 4 bar
2	with overload switch-off - 7 bar
3	with overload switch-off - 10 bar
Operating unit (HMI)	
S	HMI (0.5 m cable)
1	HMI + 2 m cable
2	HMI + 5 m cable
X	without HMI
Safety options	
0	Dosing monitor, dynamic, without access control

---

Identity code

---

S1Cb Sigma 1, Control Type, Version b

1	Dosing monitor, dynamic, with access control	
	<b>Language</b>	
	DE	German
	EN	English
	ES	Spanish
FR	French	

FPM = fluorine rubber

\* for SST = 12 bar

\*\* Pump without HMI control unit

\*\*\* Standard with tube nozzle in the bypass Threaded connection on request.



## 2 Safety chapter



### Identification of safety notes

The following signal words are used in these operating instructions to denote different severities of danger:

Signal word	Meaning
<b>WARNING</b>	Denotes a possibly dangerous situation. If this is disregarded, you are in a life-threatening situation and this can result in serious injuries.
<b>CAUTION</b>	Denotes a possibly dangerous situation. If this is disregarded, it could result in slight or minor injuries or material damage.

### Warning signs denoting different types of danger

The following warning signs are used in these operating instructions to denote different types of danger:

Warning signs	Type of danger
	Warning – high-voltage.
	Warning – danger zone.

### Correct and proper use

- The pump may only be used to dose liquid metering chemicals.
- Only SST design pumps may be used with combustible feed chemicals.
- The pump may only be started up after it has been correctly installed and commissioned in accordance with the technical data and specifications contained in the operating instructions.
- The general limitations with regard to viscosity limits, chemical resistance and density must be observed - see also ProMinent resistance list (In the product catalogue or at [www.prominent.com](http://www.prominent.com))!
- Any other uses or modifications are prohibited.
- The pump is not intended for the metering of gaseous media or solids.
- The pump is not intended for operation in hazardous locations.
- The pump is not intended for exterior applications without use of suitable protective equipment.
- The pump should only be operated by trained and authorised personnel, see the following "Qualifications" table.
- You are obliged to observe the information contained in the operating instructions at the different phases of the device's service life.

### Safety notes



#### **WARNING!**

##### **Warning of dangerous or unknown feed chemical**

Should a dangerous or unknown feed chemical be used: It may escape from the hydraulic components when working on the pump.

- Take appropriate protective measures before working on the pump (e.g. safety glasses, safety gloves, ...). Observe the safety data sheet for the feed chemical.
- Drain and flush the liquid end before working on the pump.



#### **WARNING!**

##### **Danger from hazardous substances!**

Possible consequence: Fatal or very serious injuries.

Please ensure when handling hazardous substances that you have read the latest safety data sheets provided by the manufacture of the hazardous substance. The actions required are described in the safety data sheet. Check the safety data sheet regularly and replace, if necessary, as the hazard potential of a substance can be re-evaluated at any time based on new findings.

The system operator is responsible for ensuring that these safety data sheets are available and that they are kept up to date, as well as for producing an associated hazard assessment for the workstations affected.



#### **CAUTION!**

##### **Warning of feed chemical spraying around**

Feed chemical can spray out of the hydraulic components if they are manipulated or opened due to pressure in the liquid end and adjacent parts of the system.

- Disconnect the pump from the mains power supply and ensure that it cannot be switched on again by unauthorised persons.
- Depressurise the system before commencing any work on hydraulic parts.



#### **CAUTION!**

##### **Warning of feed chemical spraying around**

An unsuitable feed chemical can damage the parts of the pump contacted by the chemical.

- Take into account the resistance of the materials which will come into contact with the chemical when selecting the feed chemical - see the ProMinent product catalogue or under [www.prominent.com](http://www.prominent.com).



#### **CAUTION!**

##### **Danger of personnel injury and material damage**

The use of untested third party parts can result in personnel injuries and material damage.

- Only fit parts to metering pumps, which have been tested and recommended by ProMinent.



**CAUTION!**

**Danger from incorrectly operated or inadequately maintained pumps**

Danger can arise from a poorly accessible pump due to incorrect operation and poor maintenance.

- Ensure that the pump is accessible at all times.
- Adhere to the maintenance intervals.



**CAUTION!**

**Warning of illegal operation**

Observe the regulations that apply where the unit is to be installed.



**WARNING!**

At the pump an on/off switch can be lacking, depending on identitycode and installation.

**Information in the event of an emergency**

In the event of an electrical accident, disconnect the mains cable from the mains or press the emergency cut-off switch fitted on the side of the system!

If feed chemical escapes, also depressurise the hydraulic system around the pump as necessary. Adhere to the safety data sheet for the feed chemical.

**Qualification of personnel**

Activity	Qualification level
Storage, transport, unpacking	Instructed person
Assembly, installation of hydraulic system	Technical personnel, service
Installation, electrical	Electrical technician
Operation	Instructed person
Maintenance, repair	Technical personnel, service
Decommissioning, disposal	Technical personnel, service
Troubleshooting	Technical personnel, electrical technician, instructed person, service

**Explanation of the terms:**

**Technical personnel**

A qualified employee is deemed to be a person who is able to assess the tasks assigned to him and recognise possible dangers based on his/her technical training, knowledge and experience, as well as knowledge of pertinent regulations.

Note:

A qualification of equal validity to a technical qualification can also be gained by several years employment in the relevant work area.

**Electrical technician**

Electrical technicians are deemed to be people, who are able to complete work on electrical systems and recognize and avoid possible dangers independently based on their technical training and experience, as well as knowledge of pertinent standards and regulations.

Electrical technicians should be specifically trained for the working environment in which they are employed and know the relevant standards and regulations.

Electrical technicians must comply with the provisions of the applicable statutory directives on accident prevention.

**Instructed person**

An instructed person is deemed to be a person who has been instructed and, if required, trained in the tasks assigned to him/her and possible dangers that could result from improper behaviour, as well as having been instructed in the required protective equipment and protective measures.

**Service**

Customer Service department refers to service technicians, who have received proven training and have been authorised by ProMinent or Pro-Maqua to work on the system.

**Sound pressure level**

Sound pressure level  $L_{pA} < 70$  dB in accordance with EN ISO 20361:2010-10

at maximum stroke length, maximum stroke rate, maximum back pressure (water)

### 3 Storage, transport and unpacking

#### Safety notes



#### WARNING!

Only return metering pumps for repair in a cleaned state and with a flushed liquid end - refer to the section on decommissioning!

Only send metering pumps with a filled in Decontamination Declaration form. The Decontamination Declaration constitutes an integral part of an inspection / repair order. A unit can only be inspected or repaired when a Declaration of Decontamination Form is submitted that has been completed correctly and in full by an authorised and qualified person on behalf of the pump operator.

You can find the "Decontamination Declaration" form under [www.prominent.com](http://www.prominent.com) or on the CD.



#### CAUTION!

#### Danger of material damage

The device can be damaged by incorrect or improper storage or transportation!

- The unit should only be stored or transported in a well packaged state - preferably in its original packaging.
- The packaged unit should also only be stored or transported in accordance with the stipulated storage conditions.
- The packaged unit should be protected from moisture and the ingress of chemicals.

#### Scope of supply

Compare the delivery note with the scope of supply:

- Metering pump with mains power cable
- If necessary, connector kit for hose/pipe connection
- Product-specific operating instructions with EC Declaration of Conformity
- General Operating Instructions ProMinent motor-driven metering pumps and hydraulic accessories
- As necessary, documents for options and accessories

#### Storage

Personnel:                    ■ Technical personnel

1. ➤ Plug the caps on the valves.
3. ➤ Preferably place the pump standing vertically on a pallet and secure against falling over.
4. ➤ Cover the pump with a tarpaulin cover - allowing rear ventilation.

Store the pump in a dry, closed shop under the following ambient conditions.

### Ambient conditions

Data	Value	Unit
Minimum storage and transport temperature	-10	°C
Maximum storage and transport temperature	+50	°C
Maximum air humidity *	95	% rel. humidity

\* non-condensing

## 4 Overview of equipment and control elements

### Overview of equipment

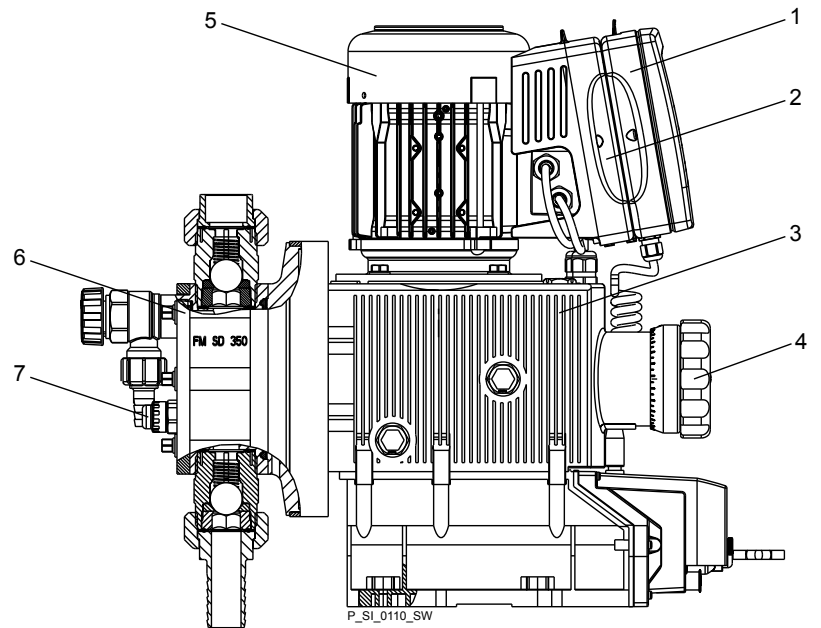

Fig. 2: Overview of equipment S1Cb

- 1 HMI control unit
- 2 Frequency converter
- 3 Drive unit
- 4 Stroke length adjustment wheel
- 5 Drive motor
- 6 Liquid end
- 7 Diaphragm rupture sensor

### Control elements

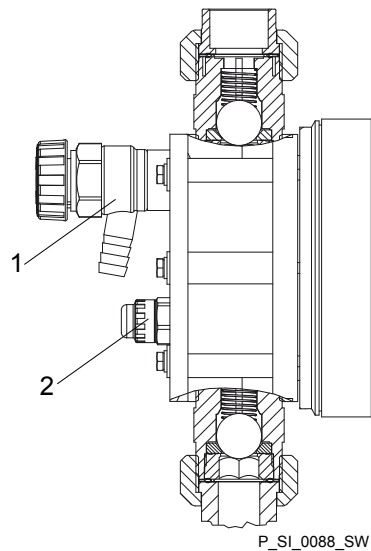

Fig. 3: Sigma control elements

- 1 Bleed valve (Option)
- 2 Diaphragm rupture sensor (visual)

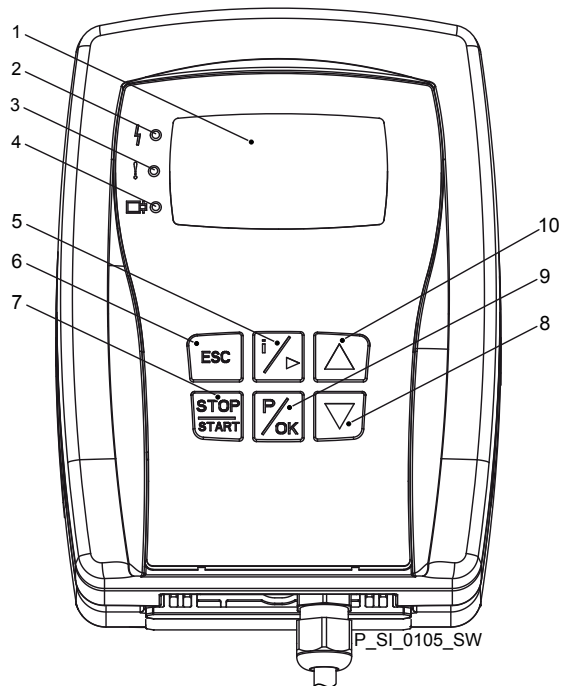

Fig. 4: HMI control elements

- 1 LCD screen
- 2 Fault indicator (red)
- 3 Warning indicator (yellow)
- 4 Operating indicator (green)
- 5 [i] key / Cursor to right
- 6 [ESC] key
- 7 [START/STOP] key
- 8 [DOWN] key
- 9 [P / OK] key
- 10 [UP] key

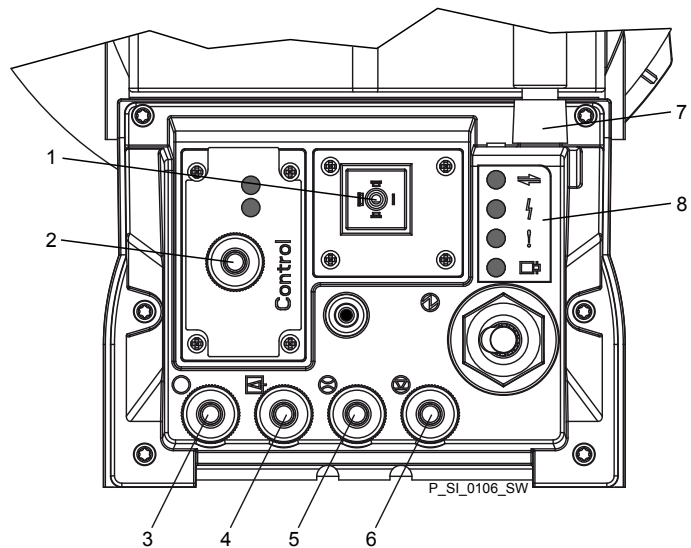







Fig. 5: Connector cover control elements

- 1 Relay and mA-output (option)
  - 2 Optional module slot (timer, PROFIBUS®)
  - 3 "Diaphragm rupture" terminal
  - 4 "External control" terminal
  - 5 "Dosing monitor" terminal
  - 6 "Level Switch" terminal
  - 7 "CAN-bus" port (external)
  - 8 LEDs (as Fig. 4) and status LED CAN bus (external)
- not shown Stroke length adjustment wheel



## 4.1 Key functions

Key	Application	In continuous displays (operation)	In adjustment mode (set up)
			
[STOP/START]	Pressed briefly	Stop pump, start pump	Stop pump, start pump
			
[P / OK]	Pressed briefly	Start batch (only in 'Batch' operating mode), Acknowledge errors	Confirm entry - jump to next menu option or to continuous display
	Pressed for 2 s	Change to adjustment mode	-
			
[i / >]	1x short press	Change between the continuous displays Change between the secondary displays	Change between "Changing individual numbers" and "Changing a number" Change to the next digit
	1x long press	Change from the continuous displays to the secondary displays	
			
[UP], [DOWN]	Pressed briefly	Change directly changeable variables	Select another setting, change individual number or number.
	Simultaneous long press	Priming	-
			
[ESC]	Pressed briefly	-	Jumps back one menu level
	Pressed for 2s	-	Jumps to a continuous display Exit the setting menu without saving

## 4.2 LCD screen identifiers

The LCD screen supports the operation and adjustment of the pump using different identifiers:

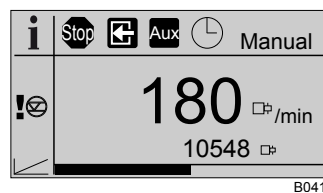



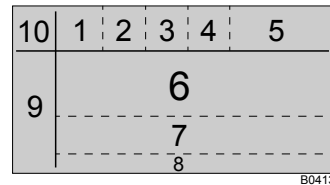



The identifiers and information in the various fields of the LCD screen have different meanings:



- 1 Operating main display
- 2 Source indicator for stop
- 3 Auxiliary operation / Diaphragm break sensor deactivated
- 4 Module option
- 5 Mode
- 6 Main display
- 7 Secondary display
- 8 Display type (number of pages)
- 9 Other identifiers, error source indicator
- 10 Continuous display identifier (" i " as "Info")

The identifiers have the following meanings:

Field no.	Icon	Name	Meaning
1		Stop	The pump is stopped. Cause see field 2.
1		Priming	The pump is currently priming (both <i>[arrow keys]</i> pressed).
2		Manual	The pump was stopped manually.
2		External signal	The pump was externally stopped by the Pause contact.
2		Timer	The pump was stopped via the timer.
2	CAN open	CANopen	The pump was stopped via the external CAN bus.
2	Profi bus	PROFIBUS®	The pump was externally stopped by the PROFIBUS®.
3	Aux	Auxiliary	The pump is currently pumping with the auxiliary frequency as the stroke rate. During this time, the pump is in <i>'Manual'</i> operating mode.
3	dia	Diaphragm rupture	A diaphragm rupture sensor is connected, but deactivated.
4		Timer	The "Timer" option is active.
4	CAN open	CANopen	The "CANopen" option is active.
4	Profi bus	PROFIBUS®	The "PROFIBUS®" option is active.
5	MANUAL	<i>'Manual'</i>	<i>'Manual'</i> operating mode
5	CONTACT	<i>'Contact'</i>	<i>'Contact'</i> operating mode
5	BATCH	<i>'Batch'</i>	<i>'Batch'</i> operating mode

Field no.	Icon	Name	Meaning
5	ANALOG	'Analog'	'Analog' operating mode
9		Error	A fault exists.
9		Stroke length adjustment	Deviation in the stroke length from the value set at the time of the last locking of the setting menu.
9		Flow control	A flow control is connected.
9	<b>m</b>	Memory	The pump is in operating mode 'Contact' or 'Batch' and the auxiliary function "Memory" is set.
9	<b>0..20</b>	0...20 mA	The pump is in operating mode 'Analog'. The processing type '0...20' is set.
9	<b>4..20</b>	4...20 mA	The pump is in operating mode 'Analog'. The processing type '4...20' is set.
9		Linear	The pump is in operating mode 'Analog'. The processing type 'Curve'- 'Linear' is set.
9		Upper sideband	The pump is in operating mode 'Analog'. The processing type 'Curve'- 'Upper sideband' is set.
9		Lower sideband	The pump is in operating mode 'Analog'. The processing type 'Curve'- 'Lower sideband' is set.
10	<b>i</b>	Continuous display	A continuous display appears on the LCD screen.
10		Security	Security lock (if a code was set).



*For identifiers which appear in response to errors, see the "Troubleshooting" chapter.*

## 5 Functional description

### 5.1 Drive unit

The metering pump is an diaphragm pump, the stroke length of which can be adjusted. An electric motor (1) drives the pump. A worm gear (2) steps down its drive rotation A cam (3), in conjunction with the uptake fork (8) converts this into an oscillation movement of the slide rod (4). A return spring (5) presses the uptake fork together with the slide rod positively against the cam thus producing the reciprocal stroke. The stroke length can be adjusted using the stroke adjustment dial (6) and the axle (7). The different stroke lengths are in effect caused by a limitation of the return stroke, see figure. The slide rod transmits the stroke motion to the metering diaphragms.

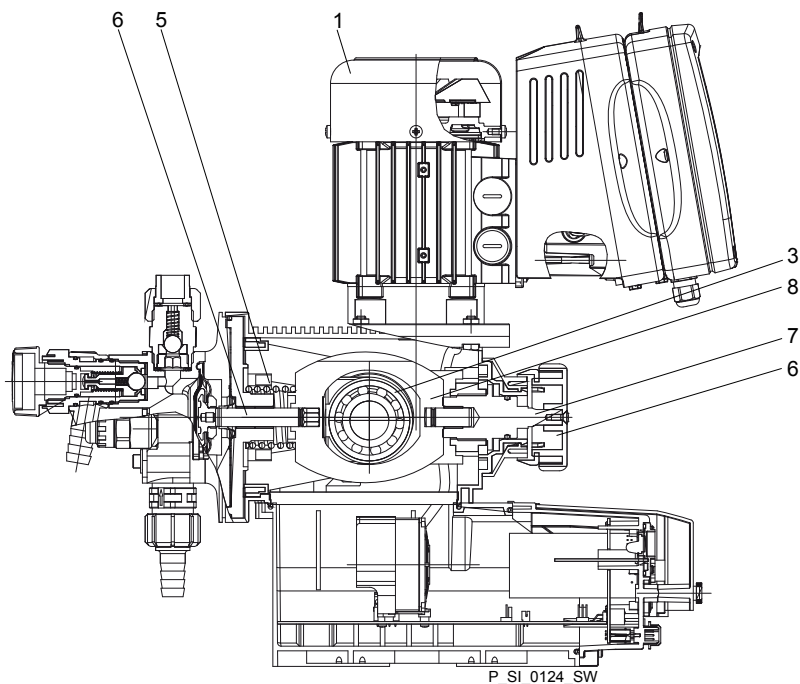

Fig. 6: Section through the drive unit Sigma 1

- 1 Electric motor
- 2 Worm gear (not visible)
- 3 Eccentric cam
- 4 Slide rod
- 5 Return spring
- 6 Stroke adjustment dial
- 7 Axle
- 8 Uptake fork

#### Illustration of the stroke movement

The stroke movement of the displacement body is continuously measured and regulated so that the stroke is executed according to a previously set dosing profile, see chapter 'Set-up' - 'Metering'.

The following dosing profiles are available:

- Normal
- Discharge opti.
- Suction opti.

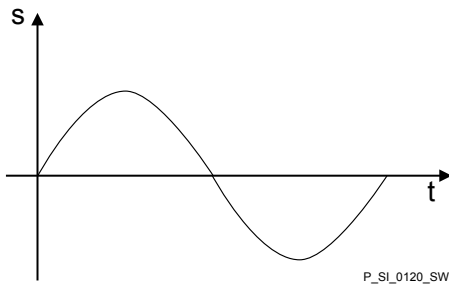

**Normal**

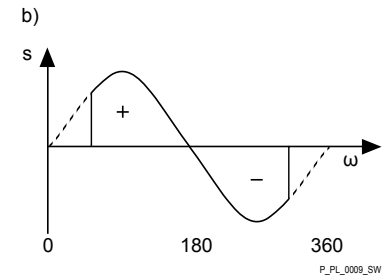
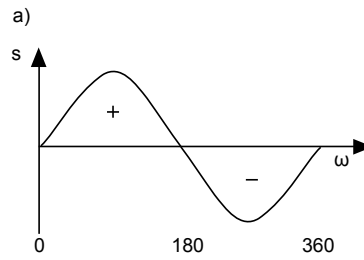
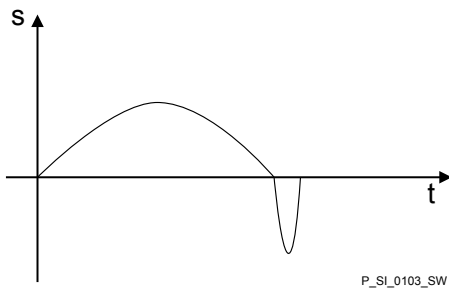

Fig. 7: Stroke movement at a) maximum stroke length and b) reduced stroke length.

- t Stroke velocity
- $\omega$  Cam rotational angle
- + Discharge stroke
- Suction stroke

**Discharge opti.**

With a discharge optimised dosing profile, the discharge stroke is elongated, the suction stroke is executed as quickly as possible. This setting is for example suitable for those applications that require optimum mixing ratios and as continuous as possible chemical mixing.



**Suction opti.**

With a suction optimised dosing profile, the suction stroke is elongated as much as possible, which makes possible a precise and problem-free dosing of viscous and gaseous media. This setting should also be chosen to minimise the NPSH value.

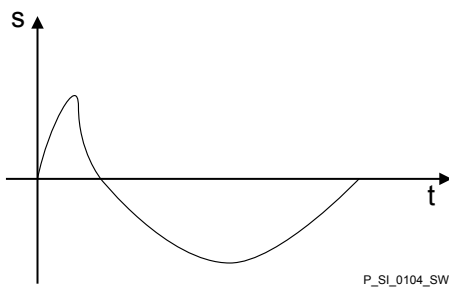

**5.2 Liquid end**

The diaphragm (2) hermetically shuts off the pump volume of the dosing head (4) towards the outside. The suction valve (1) closes as soon as the diaphragm (2) is moved in to the dosing head (4) and the feed chemical flows through the discharge valve (3) out of the dosing head. The discharge valve (3) closes as soon as the diaphragm (2) is moved in the opposite direction due to the vacuum pressure in the dosing head and fresh feed chemical flows through the suction valve (1) into the dosing head. One cycle is thus completed.

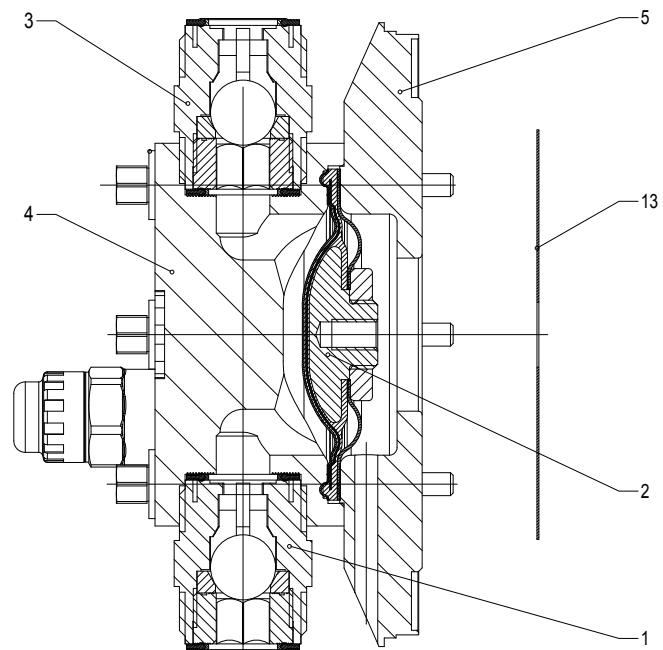
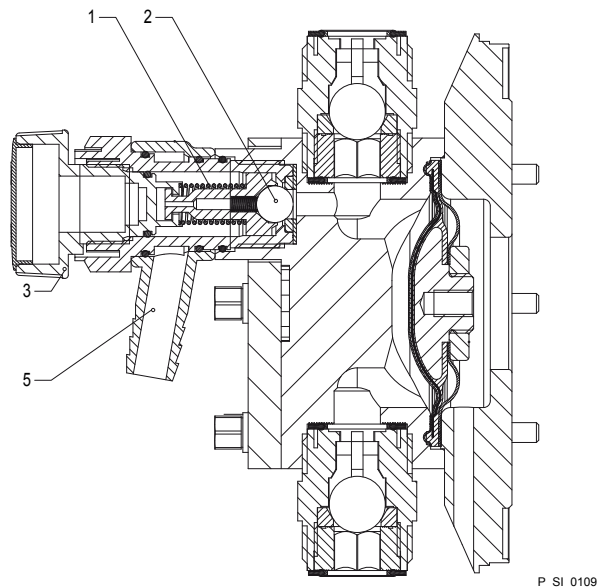

Fig. 8: Cross-section through the liquid end

- 1 Suction valve
- 2 Diaphragm
- 3 Discharge valve
- 4 Dosing head
- 5 Backplate
- 13 Safety diaphragm

### 5.3 Integral bleed valve

The integral bleed valve normally operates as a simple, directly controlled bleed valve. As soon as the pressure exceeds the pressure value, which is set using the large spring (1), it lifts the ball (2). The feed chemical then flows out through the hose connection (5), e.g. into a storage tank.



P\_SI\_0109

Fig. 9: Integral bleed valve

- 1 Spring, large
- 2 Ball
- 3 Rotary dial
- 5 Hose connection

## 5.4 Multi-layer safety diaphragm

The multi-layer safety diaphragm has the same function as the conventional double diaphragm system with working and safety diaphragms; however it also has the advantage that both diaphragms are joined together in a single unit.

If the working layer (1) breaks, the feed chemical penetrates between the working and safety (2) layers and spreads out. The safety layer ensures that not feed chemical penetrates to the outside.

As soon as the feed chemical reaches the flap (3) on the edge of the multi-layer safety diaphragm, it inflates it. The flap presses a piston (4) in the membrane rupture sensor (5), so that this triggers.

With the **visual** diaphragm rupture sensor, the lowered red cylinder (6) springs forward beneath the transparent cover (7) so that it then becomes clearly visible Fig. 10.

With the **electrical** diaphragm rupture sensor, a switch is switched. A connected signalling device must signal the diaphragm rupture.



Fig. 10: Visual diaphragm rupture sensor, triggered and untriggered

The electrical diaphragm rupture sensor is connected to the "diaphragm rupture indicator" terminal. If a diaphragm rupture occurs, the red LED 'Fault' indicator illuminates on the pump, the identifier 'Error' and 'DIAPH' flash on the LCD screen. Dependent on the identity code variant selected under "Displacement body", the pump either continues metering ( 'Pump emits alarm') or stops ( 'Pump stops').

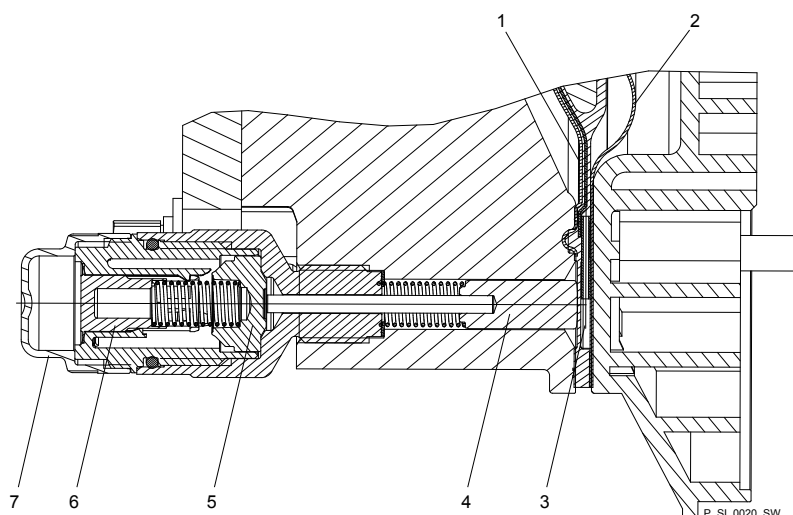

Fig. 11: Section through the Sigma diaphragm rupture warning system ("Visual break indicator" version)

- 1 Working layer ( $\hat{=}$  operating diaphragm)
- 2 Safety layer ( $\hat{=}$  safety diaphragm)
- 3 Flap
- 4 Piston
- 5 Diaphragm rupture sensor
- 6 Cylinder, red
- 7 Cover, transparent

## 5.5 Operating modes

The operating modes are selected via the *'Mode'* menu (dependent on the identity code, some operating modes may not be present):

***'Analog'* operating mode** The stroke rate is controlled using an analog current signal via the "External control" terminal. Processing of the current signal can be preselected via the control unit.

***'Manual'* operating mode** The stroke rate is set manually via the control unit.

***'Contact'* operating mode:** This operating mode provides the option of making fine adjustments using small scaling or transfer factors. The metering can be triggered either by a pulse received via the "External control" terminal or through a contact or a semiconductor switching element. A metering quantity (batch) or a number of strokes (scaling or transfer factor 0.01 to 100.00) can be pre-selected via the control unit using the *'Factor'* setting.

***'Batch'* operating mode:** This operating mode provides the option of working with large transfer factors (up to 99,999). The metering can be triggered either by pressing the *[P]* key or by a pulse received via the "External control" terminal or through a contact or a semiconductor switching element. It is possible to pre-select a metering quantity (batch) or a number of strokes via the control unit.

***'BUS'* operating mode** (Identity code, control variant: CANopen or PROFIBUS® DP interface). This operating mode provides the option of controlling the pump via BUS (see "Supplementary instructions for ProMinent delta and Sigma with PROFIBUS®").

## 5.6 Functions

The following function can be ordered via the identity code:

**Overload switch-off:** As the power consumption is monitored, the pump may switch off electronically if a defined tolerance range is exceeded. The overload switch-off is to protect the pump, not the system.

The following functions can be selected using the *'Settings'* menu:

**"Calibrate" function:** The pump can also be operated in the calibrated state in all operating modes. In this case, the corresponding continuous displays can then indicate the metering volume or the capacity directly. Calibration is maintained throughout the stroke rate range. The calibration is also maintained when the stroke length is altered by up to  $\pm 10\%$  scale divisions.

**"Auxiliary frequency" function:** Enables a freely selectable and programmable stroke rate to be switched on in the *'Settings'* menu, which can be controlled via the "external control" terminal. This auxiliary frequency has priority over the operating mode stroke rate settings.



**"Flow" function:** Stops the pump when the flow is insufficient, provided a dosing monitor is connected. The number of defective strokes, after which the pump is switched off, can be set in the *'Settings'* menu.

The following functions are available as standard:

**"Level switch" function:** Information about the liquid/powder level in the chemical feed container is reported to the pump control. To do so, a two-stage level switch must be fitted; it is connected to the "Level switch" terminal.

**"Pause" function:** The pump can be remotely stopped via the "External Control" terminal. The "Pause" function only works via the "External Control" terminal.

The following functions are triggered by a key press:

**"Stop" function:** The pump can be stopped without disconnecting it from the mains/power supply by pressing the *[STOP/START]* key.

**"Priming" function:** Priming (short-term transport at maximum frequency) can be triggered by simultaneous pressing of the two arrow keys.

## 5.7 Options

### Relay option

The pump has several connection possibilities for the following options:

**"Output relay" option:** In the event of fault signals, warning signals, stopping of the pump or tripped level switches, the relay connects to complete an electric circuit (for alarm horns etc.).

The relay can be retrofitted via a knock-out in the drive unit.

The various functions can be adjusted, see "Settings" - "Relay".

**"Fault indicating and semiconductor relay" option** In the event of fault signals, warning signals, stopping of the pump or tripped level switches, the fault indicating relay connects to complete an electric circuit (for control panel etc.).

In addition to the fault indicating relay, the pacing relay can be used to make a contact every stroke.

Other functions can be adjusted, see "Settings" - "Relay". The option can be retrofitted via a knock-out in the drive unit.

### Option "0/4-20 mA analog current output and fault indicating relay"

The I signal of the current output signals the currently calculated pump metering volume.

The option "0/4-20 mA analog current output and fault indicating relay" can be retrofitted via a knock-out in the control unit.

Additionally the option always provides a semiconductor relay, see above. Other functions can be adjusted, see "Settings" - "Relay".

## 5.8 Function and fault indicator

The operating and fault statuses are indicated by the three LED indicators and the 'Error' identifier on the LCD screen, see also the "Troubleshooting" chapter.

## 5.9 LCD screen

If a fault occurs, the identifier 'Error' appears and an additional error message.

## 5.10 LED displays

**CANopen status indicator (green):** The CANopen status indicator shows the status of the CANopen bus.

Colour	Flash code	Cause	Consequence	Remedy
green	illuminated	Bus status OPERATIONAL	Normal bus mode	-
green	flashing	Bus status PRE-OPERATIONAL	currently no measured value communication	wait briefly. Disconnect HMI then reconnect
red	any	Bus-error	no measured value communication	Check whether the CAN connection is faulty. Contact customer service

Contact customer service in the event of all other flash codes.

**Fault indicator (red):** The fault indicator illuminates if a fault occurs e.g. liquid level low 2nd stage".

**Warning indicator (yellow):** The warning indicator illuminates if the pump electronics detect a condition which may lead to a fault, e.g. "liquid level low 1st stage".

**Operating indicator (green):** The operating indicator illuminates provided the pump is correctly connected to the operating voltage. The operating indicator goes out briefly with every stroke.

## 5.11 Hierarchy of operating modes, functions and fault statuses

The different operating modes, functions and fault statuses have a different effect on if and how the pump reacts.

The following list shows the order:

1. - Priming
2. - Fault, Stop, Pause
3. - Auxiliary frequency (external frequency changeover)
4. - Manual, external contact, batch, external analog

Comments:

- re 1 - "Priming" can take place in any mode of the pump (providing it is functioning).
- re 2 - "Fault", "Stop" and "Pause" stop everything apart from "Priming".
- re 3 - The "Auxiliary frequency" stroke rate always has priority over the stroke rate specified by an operating mode listed under 4.

## 6 Assembly



### CAUTION!

#### Danger of material damage

The device can be damaged by incorrect or improper storage or transportation!

- The unit should only be stored or transported in a well packaged state - preferably in its original packaging.
- The packaged unit should also only be stored or transported in accordance with the stipulated storage conditions.
- The packaged unit should be protected from moisture and the ingress of chemicals.



### CAUTION!

#### Warning about personal and material damage

Personal and material damage may be caused if the unit is operated outside of the permissible ambient conditions.

- Please observe the permissible ambient conditions - refer to the chapter entitled "Technical Data".

### Supporting floor

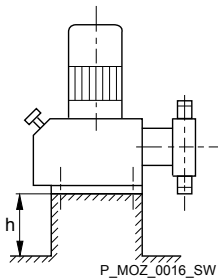

Fig. 12



### WARNING!

#### Danger of electric shock

If water or other electrically conducting liquids penetrate into the drive housing, in any other manner than via the pump's suction connection, an electric shock may occur.

- Position the pump so that it cannot be flooded.



### WARNING!

#### The pump can break through the supporting floor or slide off it

- The supporting floor must be horizontal, smooth and permanently load-bearing.



### Capacity too low

*Vibrations can disturb the valves of the liquid end.*

- *The supporting floor must not vibrate.*

Space requirement

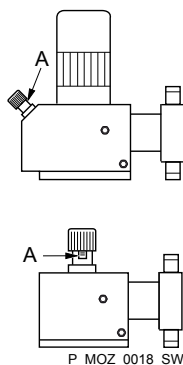

Fig. 13

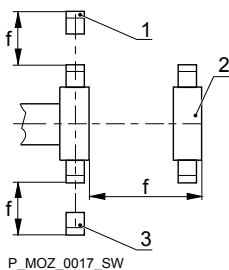

Fig. 14

Liquid end alignment



**CAUTION!**

**Danger from incorrectly operated or inadequately maintained pumps**

Danger can arise from a poorly accessible pump due to incorrect operation and poor maintenance.

- Ensure that the pump is accessible at all times.
- Adhere to the maintenance intervals.

Position the pump so that control elements such as the stroke length adjustment knob, the indicating dial A or the oil inspection window are accessible.

In so doing, ensure there is enough space to carry out an oil change (vent screws, oil drain plugs, oil trough ...).

- 1 Discharge valve
- 2 Dosing head
- 3 Suction valve

Ensure there is sufficient free space (f) around the dosing head as well as the suction and discharge valve so that maintenance and repair work can be carried out on these components.



**Capacity too low**

*If the valves of the liquid end do not stand upright, they cannot close correctly.*

- *The discharge valve must be upright.*

Fastening



**Capacity too low**

*Vibrations can disturb the valves of the liquid end.*

- *Secure the metering pump so that no vibrations can occur.*

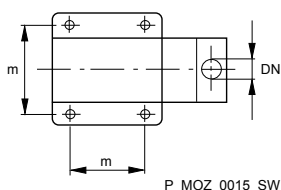

Fig. 15

Take the dimensions (m) for the fastening holes from the appropriate dimensional drawings or data sheets.

Fasten the pump base to the supporting floor using suitable screws.

**Mounting the HMI user control**

If ordered with the wall mounting, the HMI can be mounted directly on a wall.

Mount the HMI in the direct environment of the pump. Look for good ergonomics.

When doing so, consider the available cable length.

Avoid tripping hazards.

For the dimensions of the HMI and fastening holes, see the corresponding dimensions sheet in the "Dimension sheets" chapter.



**CAUTION!**

**Warning of faulty operation**

- Do not install the HMI and cable too close to devices and cabling that emit strong electrical interference.

## 7 Installation

**CAUTION!****Danger of personnel injury and material damage**

The disregard of technical data during installation may lead to personal injuries or damage to property.

- Observe the technical data- refer to chapter "Technical Data" and, where applicable, the operating instructions of the accessories.

### 7.1 Installation, hydraulic

**WARNING!****Warning of feed chemical reactions to water**

Feed chemicals that should not come into contact with water may react to residual water in the liquid end that may originate from works testing.

- Blow the liquid end dry with compressed air through the suction connector.
- Then flush the liquid end with a suitable medium through the suction connector.

**WARNING!**

The following measures are an advantage when working with highly aggressive or hazardous feed chemicals:

- Install a bleed valve with recirculation in the storage tank.
- Install an additional shut-off valve on the discharge or suction ends.

**CAUTION!****Suction problems possible**

For feed chemicals with a particle size greater than 0.3 mm, the valves may no longer close properly.

- Install a suitable filter in the suction line.

**CAUTION!****Warning against the discharge line bursting**

With a closed discharge line (e.g. from a clogged discharge line or by closing a valve), the pressure that the metering pump generates can reach several times more than the permissible pressure of the system or the metering pump. This could lead to lines bursting resulting in dangerous consequences with aggressive or hazardous feed chemicals.

- Install a relief valve that limits the pressure of the pump to the maximum permissible operating pressure of the system.

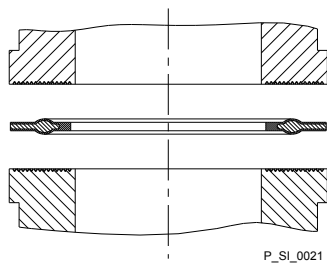

Fig. 16: Moulded composite seals with corrugated insert

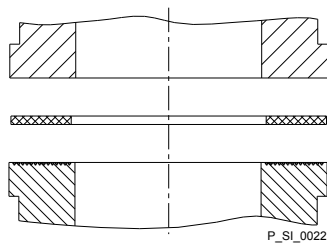

Fig. 17: Elastomer flat seal for a smooth insert



### CAUTION!

#### Warning against bursting of the suction or discharge lines

Tube lines with insufficient pressure rating may burst.

- Only use tube lines with the required pressure rating.



### CAUTION!

#### Warning against lines disconnecting

If suction, discharge and relief lines are installed incorrectly, they can loosen / disconnect from the pump connection.



- Only use original tubing with the specified tube diameter and wall thickness.
- Only use clamp rings and tube nozzles that correspond with the respective hose diameter.
- Always connect the lines without mechanical tension.



### CAUTION!

#### Warning against leaks

Leaks can occur on the pump connection depending on the insert used.

- The pump is supplied with PTFE moulded composite seals with a flare, which are used for the pump connections. They seal the connections between grooved pump valves and the grooved inserts from ProMinent - see  on page 31.
- In the event that an unflared insert is used (e.g. third party part), an elastomer flat seal must be used - see  on page 31.



Numerous installation instructions with drawings are contained in the "General Operating Instructions for ProMinent® motor-driven metering pumps and hydraulic accessories".



- *Precise metering is only possible when the back pressure is maintained above 1 bar at all times.*
- *If metering at atmospheric pressure, a back pressure valve should be used to create a back pressure of approx. 1.5 bar.*



### CAUTION!

#### Warning of backflow

A back pressure valve, spring-loaded injection valve, relief valve, foot valve or a liquid end do not represent absolutely leak-tight closing elements.

- For this purpose use a shut-off valve, a solenoid valve or a vacuum breaker.



### CAUTION!

#### Warning of illegal operation

Observe the regulations that apply where the unit is to be installed.



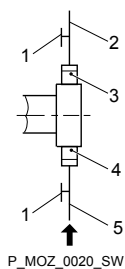

Fig. 18: Manometer connecting options



**CAUTION!**

To check the pressure conditions in the piping system it is recommended that connecting options are provided for a manometer close to the suction and pressure connector.

- 1 Manometer socket
- 2 Discharge line (pipe)
- 3 Discharge valve
- 4 Suction valve
- 5 Suction line (pipe)



**CAUTION!**

Connect the pipelines to the pump so that no residual forces act on the pump, e.g. due to the offsetting, weight or expansion of the line.

Only connect steel or stainless steel piping via a flexible piping section to a plastic liquid end.

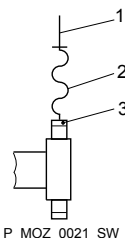

Fig. 19: Steel pipeline at the liquid end

- 1 Steel pipeline
- 2 Flexible pipe section
- 3 Plastic liquid end

**Integral bleeder valve**



**CAUTION!**

**Warning of feed chemical spraying around**

If no overflow line was connected to the integral bleeder valve, feed chemical sprays out of the tube connection as soon as the bleeder valve opens.

- An overflow line must always be connected to the integral bleeder valve and be fed back to the storage tank or - if required by the regulations - into a special storage tank.



**CAUTION!**

**Danger of cracking**

Cracking of the PVT liquid end can occur if a metal overflow line is connected to the bleeder valve.

- Never connect a metal overflow line to the bleeder valve.

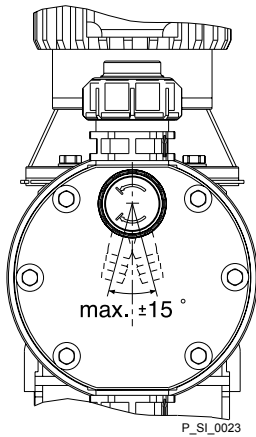

Fig. 20: Permissible alignment of the bleeder valve

### Diaphragm rupture sensor



#### CAUTION!

##### Warning against leaks

Feed chemical which remains in the overflow line at the bleeder valve, can attack the valve or cause it to leak

- Route the overflow line with a continuous slope and moreover with the tube nozzle pointed downwards - see Fig. 20.



#### CAUTION!

##### Danger resulting from unnoticed diaphragm rupture

If the pump has been ordered with an electric diaphragm rupture sensor, it still has to be installed.

- Screw the enclosed diaphragm rupture sensor into the liquid end (no seal necessary).



#### CAUTION!

##### Warning of unnoticed diaphragm rupture

Only above approximately 2 bar system back pressure is a signal generated upon a diaphragm rupture.

- Only rely on the diaphragm rupture sensor at back pressures greater than 2 bar.

## 7.2 Installation, electrical

### General safety notes



#### WARNING!

##### Danger of electric shock

Unprofessional installation may lead to electric shocks.

- All cable cores cut to length must be provided with cable end sleeves.
- The Installation, electrical of the device may only be undertaken by technically trained personnel.

### What requires electrical installation?

### What requires electrical installation?

- Level switch
- Diaphragm rupture sensor, electrical (option)
- Dosing monitor (option)
- Relay (option)
- External control
- mA output (option)
- Bus connector (option)
- Timer (option)
- Pump, power supply

## 7.2.1 Control connectors



**CAUTION!**

**Incoming signals can remain without effect**

If the universal control wire, the external/pacing cable or the level monitoring cable is shortened below 1.20 m, the pump does not detect that it is connected. Consequently a warning message (for example) can be suppressed.

- Do not shorten this cable below 1.20 m.

### Level switch, diaphragm rupture sensor (option) and dosing monitor (option)

Connect the plugs of the level switch, diaphragm rupture sensor and dosing monitor to the corresponding sockets on the front side of the control. In case of uncertainty - see chapter "Overview of equipment and control elements"



**CAUTION!**

**Danger resulting from unnoticed diaphragm rupture**

If the pump has been ordered with an electric diaphragm rupture sensor, it must also be electrically installed.

- Electrically connect the enclosed diaphragm rupture sensor.

Only with combustible media:



**CAUTION!**

**Fire danger**

The electric diaphragm rupture sensor must stop the pump immediately after a diaphragm rupture and trigger an alarm.

The pump must only be returned to service once a new diaphragm has been fitted.

### 7.2.1.1 Relay

#### 7.2.1.1.1 Output relay

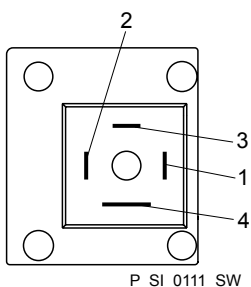

Fig. 21: Pump pin assignments

If another switching function is required, the pump can be reprogrammed in the 'Relay' menu.

The relay can be retrofitted and operates once it is plugged into the relay board.

#### Output relay

Data	Value	Unit
Maximum contact load at 230 V and 50/60 Hz:	8	A (resistive)
Minimum mechanical lifespan:	200 000	Switching operations

## Output relay

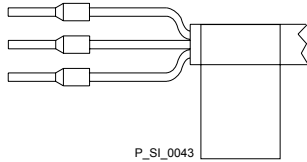

Fig. 22: Cable conductor assignments

## Pin assignment

To pin	VDE cable	Contact	CSA cable
1	white	NO (normally open)	white
2	green	NC (normally closed)	red
4	brown	C (common)	black

### 7.2.1.1.2 Fault indicating and semiconductor relay

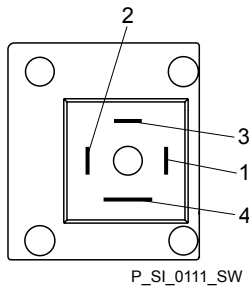

Fig. 23: Pump pin assignments

The first switch is a relay. The pacing output is electrically-isolated by means of an optocoupler with a semiconductor switch.

If another switching function is required, the pump can be reprogrammed in the 'Relay' menu.

The relay can be retrofitted and operates once it is plugged into the relay board.

## Fault indicating relay

Data	Value	Unit
Maximum contact load at 24 V and 50/60 Hz:	100	mA
Minimum mechanical lifespan:	200 000	Switching operations

## Semiconductor relay

Data	Value	Unit
Residual voltage max. at $I_{off\ max} = 1\ \mu A$	0.4	V
Maximum current	100	mA
Maximum voltage	24	VDC
Closing duration	100	ms

## Fault indicating and semiconductor relay

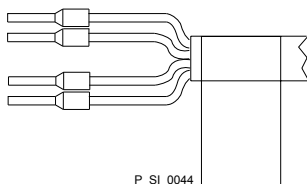

Fig. 24: Cable conductor assignments

## Pin assignment

To pin	VDE cable	Contact	Relay
1	yellow	NC (normally closed) or NO (normally open)	Fault indicating relay
4	green	C (common)	Fault indicating relay
3	white	NC (normally closed) or NO (normally open)	Semiconductor relay
2	brown	C (common)	Semiconductor relay

7.2.1.1.3 Current output plus relay

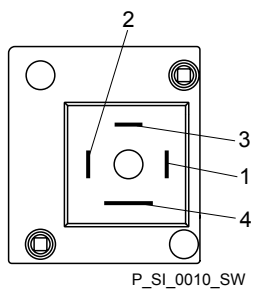

Fig. 25: Pump pin assignments

The module can be retrofitted and operates once it is plugged into the module board.

In the 'ANALOG OUTPUT' menu, the variable to be signalled by the current output can be selected.

If another switching function is required, the relay can be reprogrammed in the 'Relay' menu.

Current output

Data	Value	Unit
Open circuit voltage:	8	V
Current range:	4 ... 20	mA
Ripple, max.:	80	µA pp
Ripple, max.:	250	Ω

Fault indicating relay

Data	Value	Unit
Residual voltage max. at $I_{off\ max} = 1\ \mu A$	0.4	V
Maximum current	100	mA
Maximum voltage	24	VDC
Closing duration	100	ms

Current output and fault indicating relay

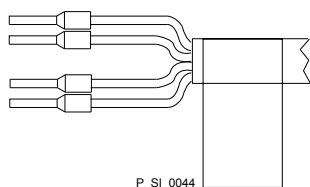
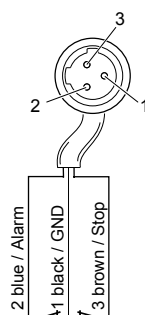
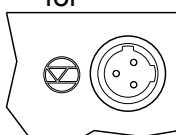
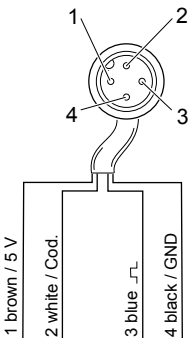
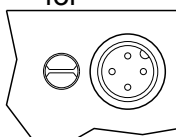
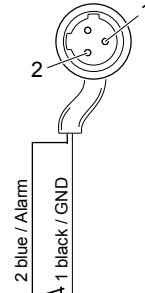
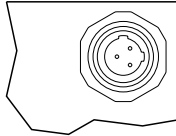

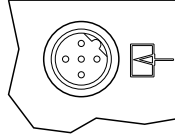
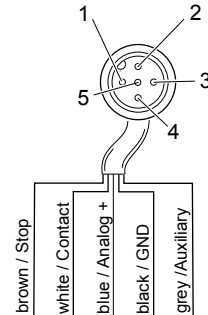

Fig. 26: Cable conductor assignments

To pin	VDE cable	Contact	Relay
1	yellow	"+"	Current output
4	green	"-"	Current output
3	white	NC (normally closed) or NO (normally open)	Fault indicating relay
2	brown	C (common)	Fault indicating relay

7.2.1.2 External control

External control

<h3>Wiring diagram</h3> <p>View of the cable plug from the front</p>	
<p><b>Level switch cable</b></p>  <p>2 blue / Alarm 1 black / GND 3 brown / Stop</p> <p>blue + black: open -&gt; Alarm message</p> <p>brown + black: open -&gt; Alarm message + Pump stopped</p>	<p>for</p> 
<p><b>Dosing monitor cable</b></p>  <p>1 brown / 5 V 2 white / Cod. 3 blue 4 black / GND</p>	<p>for</p> 
<p><b>Diaphragm rupture sensor cable</b></p>  <p>2 blue / Alarm 1 black / GND</p> <p>Contact open -&gt; Alarm message + For control type 0: Pump stopped</p>	<p>for</p> 
<p><b>External/contact cable (2-core)</b></p>  <p>2 brown 4 white</p> <p>Close contact -&gt; Metering stroke</p>	<p>for</p> 
<p><b>Universal control wire (5-core)</b></p>  <p>1 brown / Stop 2 white / Contact 3 blue / Analog + 4 black / GND 5 grey / Auxiliary</p> <p>Pause function: brown + black: closed -&gt; Pump dosing</p> <p>brown + black: open -&gt; Pump stopped</p> <p>External/Contact: white + black: close -&gt; Start contact for pump (Pause function inactive?: brown + black: closed)</p> <p>Analog: blue, black -&gt; Analog input 0/4-20 mA (Pause function inactive?: brown + black: closed)</p> <p>Auxiliary rate: grey + black: closed -&gt; Pump dosing with preset stroke rate</p> <p>➔ Wiring example - see next page</p>	

P\_SI\_0090\_SW

Technical data "external control"

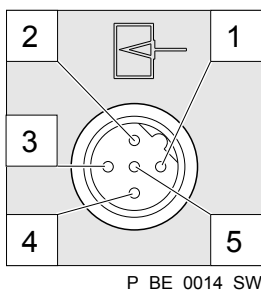

Semi-conductor switch elements with a residual voltage of  $-0.7\text{ V}$  (e.g. transistors in open-collector circuits) or contacts (relays) can be used as input switch elements.

Pin		
Pin 1 = Pause input (activating function)	Voltage with open contacts:	approx. 5 V
	Input resistance:	10 k $\Omega$
	Control:	<ul style="list-style-type: none"> <li>■ Potential-free contact (approx. 0.5 mA)</li> <li>■ Semiconductor switch (residual voltage <math>&lt; 0.7\text{ V}</math>)</li> </ul>
2 = contact input	Voltage with open contacts:	approx. 5 V
	Input resistance:	10 k $\Omega$
	Control:	<ul style="list-style-type: none"> <li>■ Potential-free contact (approx. 0.5 mA)</li> <li>■ Semiconductor switch (residual voltage <math>&lt; 0.7\text{ V}</math>)</li> </ul>
	min. contact duration:	20 ms
	Max. pulse frequency:	25 pulses/s
3 = Analog input	Input apparent ohmic resistance	approx. 120 $\Omega$
4 = GND		
5 = auxiliary input	Voltage with open contacts:	approx. 5 V
	Input resistance:	10 k $\Omega$
	Control:	<ul style="list-style-type: none"> <li>■ Potential-free contact (approx. 0.5 mA)</li> <li>■ Semiconductor switch (residual voltage <math>&lt; 0.7\text{ V}</math>)</li> </ul>

The metering pump makes its first metering stroke at approx. 0.4 mA (4.4 mA) and enters into continuous operation at approx. 19.2 mA.

Block diagram Sigma Control

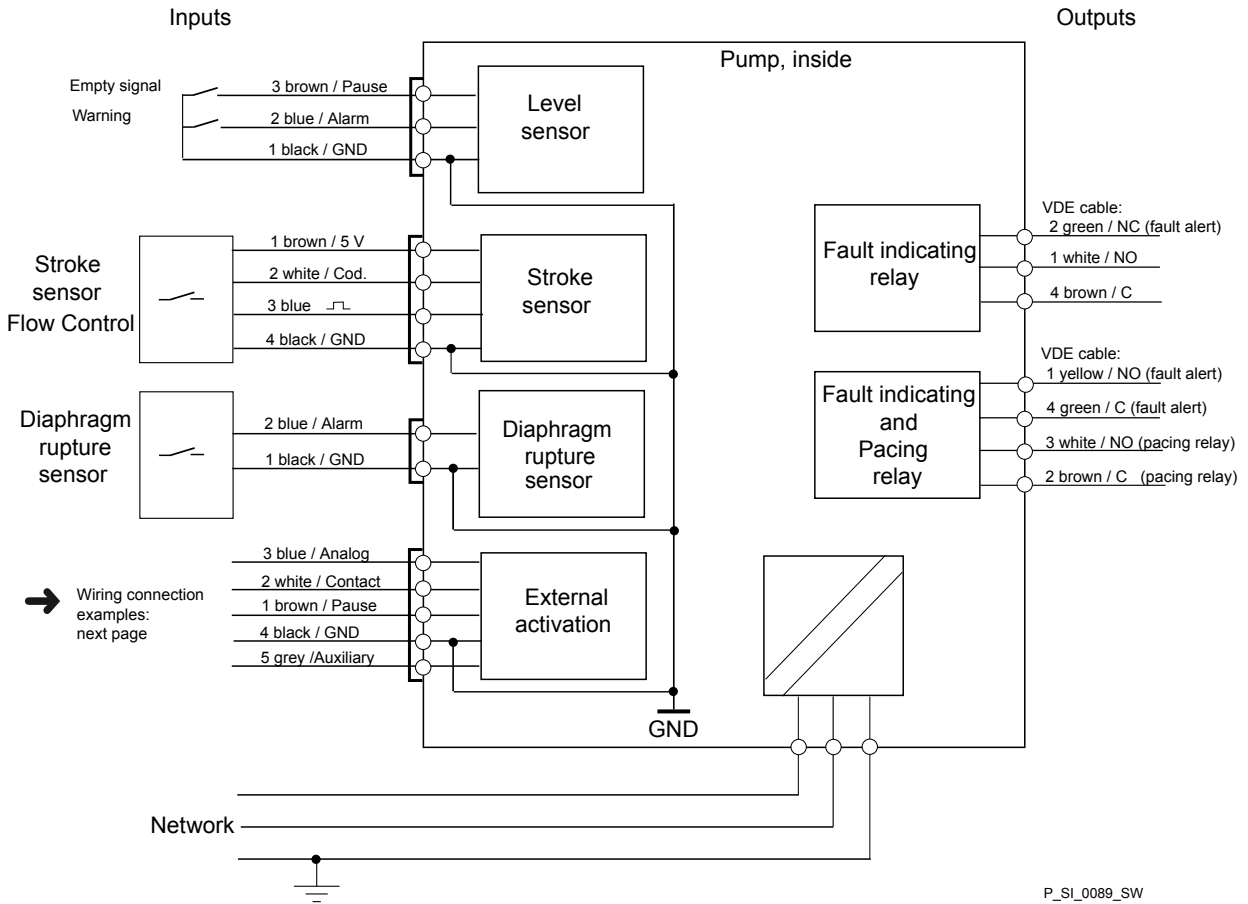

P\_SI\_0089\_SW

Fig. 27: Block diagram Sigma Control



### Universal control wire connection diagram

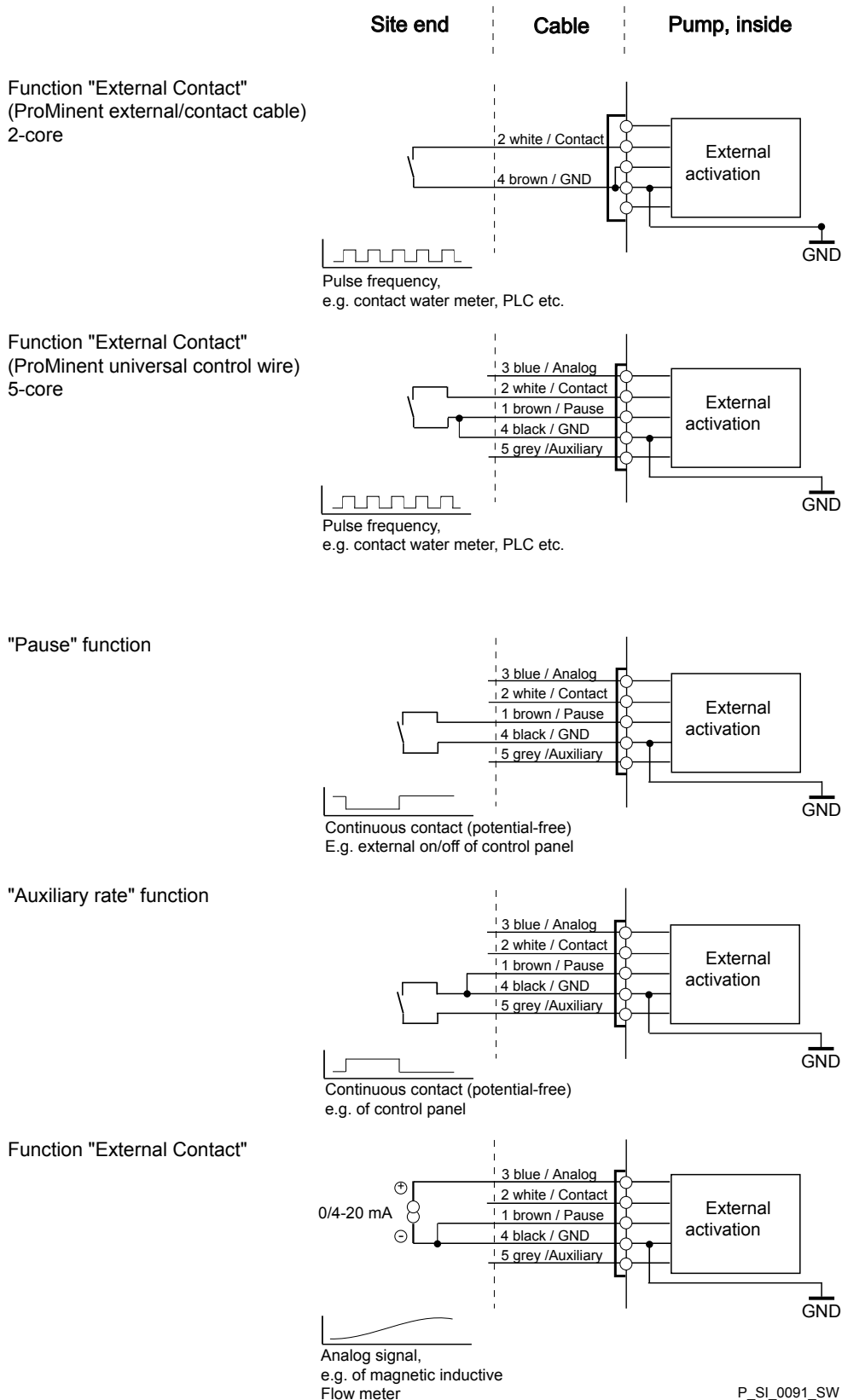

P\_SI\_0091\_SW

## 7.2.2 HMI operating unit

If the pump is operated via the HMI, the HMI must be connected to the CAN port above the LEDs of the pump base.

If the pump is operated without the HMI, the supplied sealing cap must be plugged into the CAN port above the LEDs of the pump base.



### CAUTION!

#### Risk of short circuit

If liquid penetrates into the CAN port, a short circuit may occur in the pump.

- A CAN plug or the supplied sealing cap must always be plugged into the CAN port.



### CAUTION!

#### Danger of malfunctions

Incorrect operation via the CAN bus leads to malfunctions.

- When operating with the HMI connected, do not connect any other control (e.g. DXCa) to the CAN port.

## 7.2.3 Pump, power supply



### WARNING!

#### Risk of electric shock

This pump is supplied with a grounding conductor and a grounding-type attachment plug.

- To reduce the risk of electric shock, ensure that it is connected only to a proper grounding-type receptacle.



### WARNING!

#### Danger of electric shock

In the event of an electrical accident, it must be possible to quickly disconnect the pump, and any electrical ancillaries which may possibly be present, from the mains.

- Install an emergency cut-off switch in the mains supply line to the pump and any electrical ancillaries which may be present or
- Integrate the pump and electrical ancillaries which may be present in the emergency cut-off management of the system and inform personnel of the isolating option.



### WARNING!

An on/off switch may not be fitted on the pump, dependent on the identity code and installation.



*To be able to switch off the pump (to a zero-volts state) independently from the entire installation (e.g. for repair), use an electrical isolating device in the mains supply cable, e.g. a mains switch or a plug / socket combination. Clearly identify this isolating device as such.*

→ Install the pump cable.



- *Key electrical data can be found on the pump name-plate.*

## 7.2.4 Other units

### Other units

- ➔ Install the other units according to their supplied documentation.

## 8 Set-up



- Please read the overviews in the appendix, "Control elements and key functions" and "Operating/setting diagram" for supplementary information.
- If no key is pressed for a 1 minute duration, the pump returns to a continuous display.

### 8.1 Basic principles of control adjustment

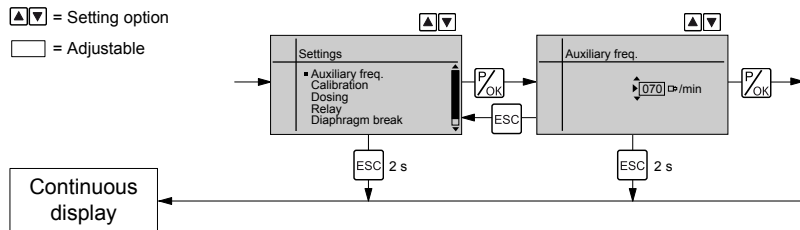

#### Confirming an entry

Briefly press the *[P/OK]* key.

The display simultaneously changes to the next selection, to the next menu option or into a continuous display.

#### Quitting a menu option without confirming it

Press *[ESC]*.

You will jump back to the previous menu option or menu.

#### Jumping back to a continuous display

Press and hold the *[ESC]* key for 2 seconds.

#### Changing adjustable values

Press the arrow keys *[UP]* or *[DOWN]*.

In this way the digit between the triangles is increased or reduced.

Select the digit position in a number using the key *[i/>]*.

#### Confirming adjustable values

Press the *[P/OK]* key.

The display simultaneously changes to the next selection, to the next menu option or into a continuous display.

### 8.2 Checking adjustable values / error messages

#### Continuous displays

Before you adjust the pump, you can check the actual settings of the adjustable variables:

- Press the key *[i/>]* ("i" for "Info"), if the pump is displaying a continuous display (An "i" is visible at the top left).
  - ⇒ Each press of the *[i/>]* key displays another continuous display or a plain text error message.
- The continuous display values can be changed using the *[arrow keys]*.



The number of continuous displays depends on the identity code, the selected operating mode and the connected additional devices, see overview "Continuous displays" in the appendix.

A horizontal scroll bar shows the number of continuous displays and error messages and the position of the displayed continuous display or error message.

With error messages an identifier appears while displays with clear text appear between the continuous displays (and an error code).

## Secondary displays

The lowest line of the Info displays (2nd level continuous display) display various information, which cannot, however, be adjusted here, see overview "Secondary displays" in the appendix.

If you are in a continuous display, you can access the bottom line of the info displays by:

1. ➤ Keep key  $[i/>]$  pressed down until a small triangle appears in the bottom line.
2. ➤ Now quickly press the  $[i/>]$  key to page through the info displays of the bottom line.

## 8.3 Changing to adjustment mode

If the  $[P/OK]$  key is pressed for 2 seconds in a continuous display, the pump changes to adjustment mode.

If under 'Service → Safety → Access protection' 'Lock menu' or 'Lock all' was set (top left key symbol instead of "i"), proceed as follows:

1. ➤ Press the  $[P/OK]$  key.
  - ⇒ The 'Password' display appears.
2. ➤ Enter the password ( $[Arrow\ keys]$ ) and confirm with the  $[P/OK]$  key.
  - ⇒ The 'Password valid' display appears.
3. ➤ Confirm the display with the  $[P/OK]$  key.
  - ⇒ The 'Main menu' appears.

The following menus can be initially chosen in adjustment mode - see also the overview "Operating/setting diagram":

- Menu 'Mode'
- Menu 'Settings'
- Menu 'Service'
- Menu 'Information'
- Menu 'Language'

To adapt the pump to your process requirements, you must:

1. ➤ Select the operating mode in the 'Mode' menu.
2. ➤ Carry out the adjustment for this operating mode under the 'Settings' menu.

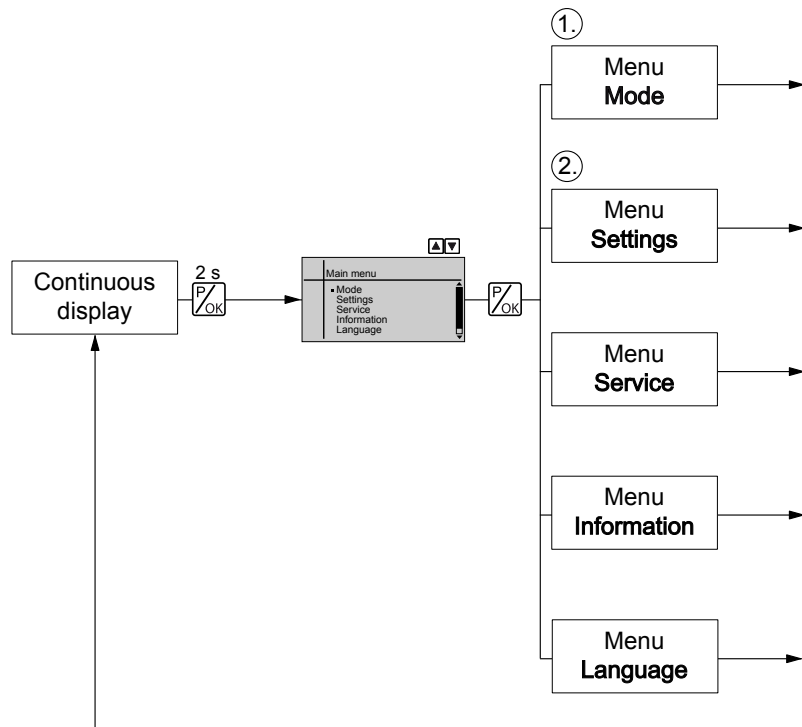

## 8.4 Selecting the operating mode (Menu "Mode")

In the *'Mode'* menu (dependent on the identity code, some operating modes may not be present) the following operating modes can be selected:

- *'Manual'*: for manual operation
- *'Batch'*: for batch operation
- *'Contact'*: for contact operation
- *'Analog'*: for current control

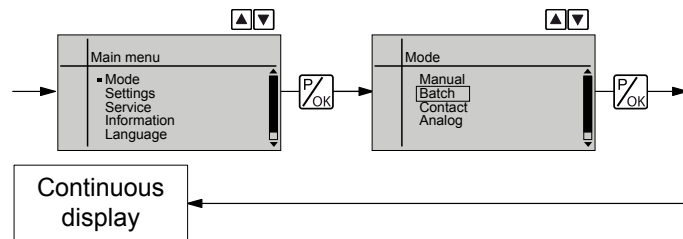

## 8.5 Operating mode settings (menu "Settings")

Various settings can be adjusted in the *'Settings'* menu dependent on the selected operating mode.

Setting menus are available in all operating modes for the following programmable functions:

- *'Auxiliary frequency'*
- *'Calibrate'*
- *'Dosing'*
- *'Diaphragm break'*
- *'System'*

See also "Programmable function settings".

As to whether or not a further setting menu is available, depends on the selected operating mode and the connected devices or modules.

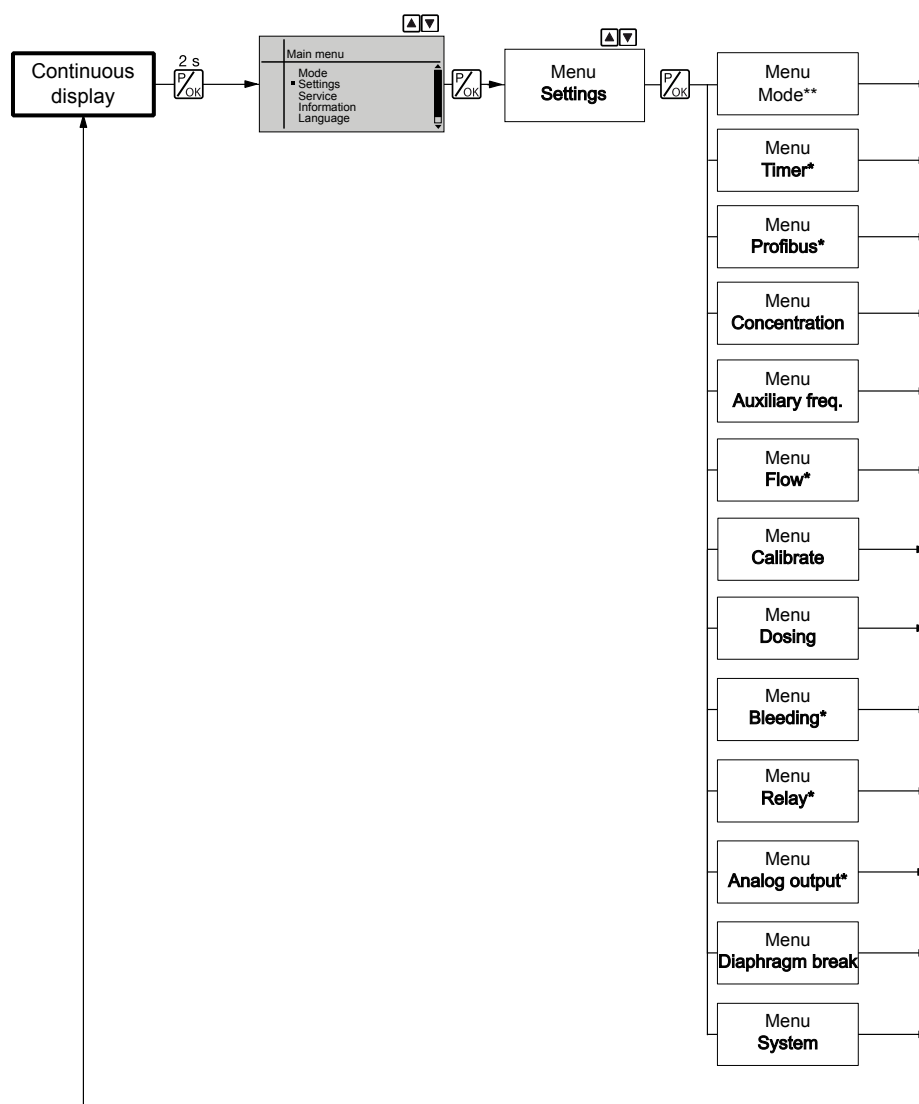

Fig. 28: "Settings" menu branch

### 8.5.1 "Manual" operating mode settings

No setting menu is available in 'Manual' operating mode in the menu 'Settings'.

### 8.5.2 "Batch" mode settings

The 'BATCH' menu is available under 'Batch' mode in the 'Settings' menu.

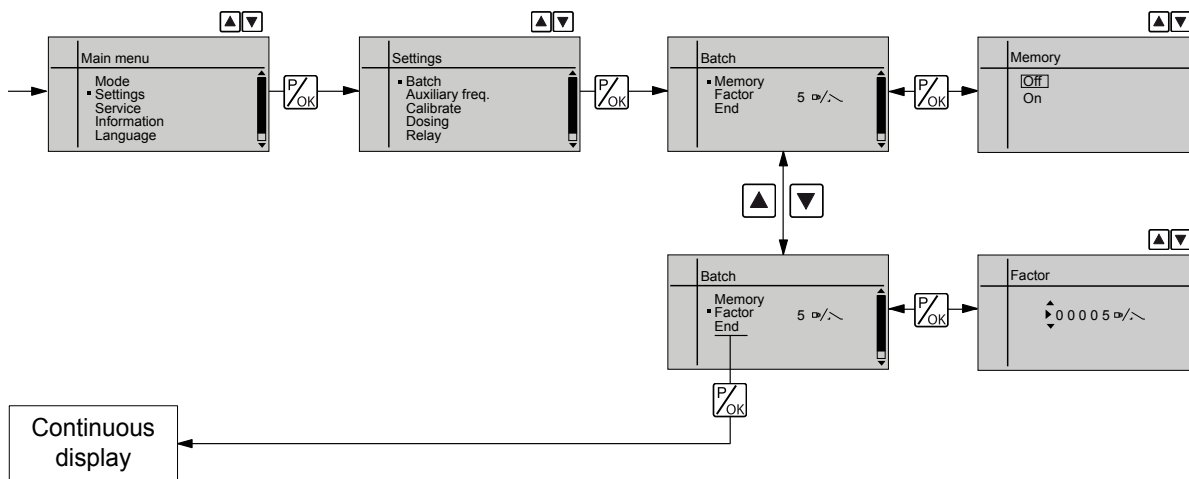

The operating mode *'Batch'* is one variant of the *'Contact'* operating mode - see the following chapter. Here also, you can select a number of strokes (no fractions, only integers from 1 to 99,999).

Operating mode *'Batch'* is intended for large metering quantities.

Metering can be triggered by pressing the *[P/OK]* key or via a pulse received via the "External Control" terminal.

The number of received pulses, which could not yet be processed, is stored by the pump in the stroke memory, if it was activated.



### CAUTION!

When changing over from the "Manual" operating mode to the "Batch" operating mode, the pump maintains the stroke rate.



*The stroke rate can also be set in 'Batch' mode. It should normally be set to the maximum stroke rate.*

## "Memory" function extension

Additionally, you can activate the "Memory" function extension (Identifier "m"). When "Memory" is activated, the pump adds up the remaining strokes, which could not be processed, up to the maximum capacity of the stroke memory of 99,999 strokes. If this maximum capacity is exceeded, the pump goes into fault mode.

## 8.5.3 "Contact" operating mode settings

The *'Contact'* menu is available under *'Contact'* mode in the *'Settings'* menu.

*'Contact'* operating mode allows you to trigger individual strokes or a stroke series.

You can trigger the strokes via a pulse sent via the "External control" terminal.

The purpose of this operating mode is to convert the incoming pulses with a reduction (fractions) or small step-up into strokes.



**CAUTION!**

When changing over from 'Manual' operating mode to 'Contact' operating mode, the pump maintains the stroke rate.



The stroke rate can also be set in 'Contact' operating mode. It should normally be set to the maximum stroke rate.

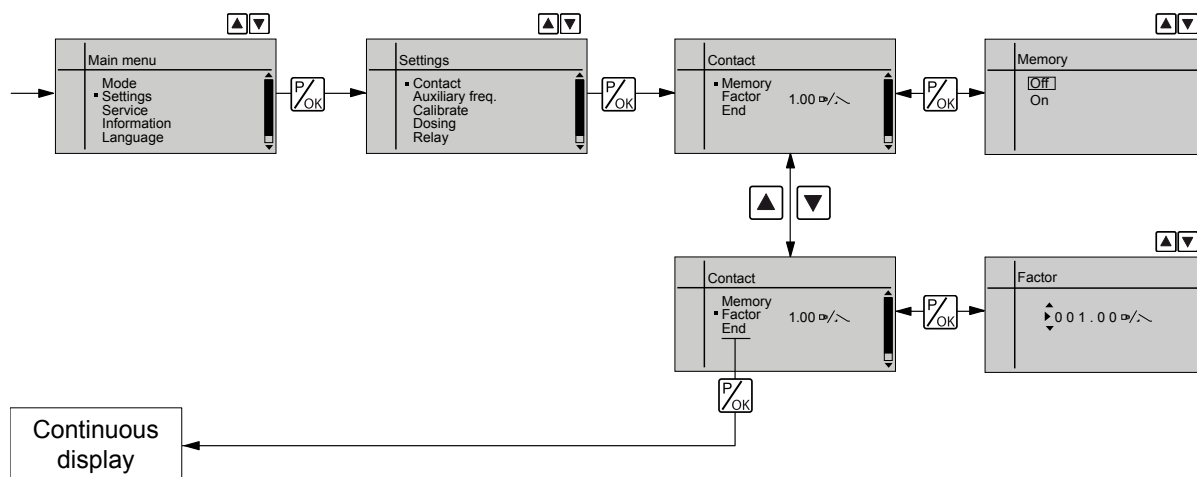

The number of strokes per pulse depends on the factor which you input. By use of the factor you can multiply incoming pulses by a factor between 1.01 and 100.00 or reduce them by a factor of 0.01 to 1.00.

Number of strokes executed = factor x number of incoming pulses

Example table

	Factor	Pulse (sequence)	Number of strokes (sequence)
<b>Step-up*</b>			
	1	1	1
	2	1	2
	25	1	25
	100.00	1	100.00
	1.50	1	1.50 (1 / 2)
	1.25	1	1.25 (1 / 1 / 1 / 2)
<b>Reduction**</b>			
	1	1	1
	0.50	2	1
	0.10	10	1
	0.01	100	1
	0.25	4	1
	0.40	2.5 (3 / 2)	(1 / 1)
	0.75	1.33 (2 / 1 / 1)	(1 / 1 / 1)

\* Explanation of the conversion ratio

With a factor of 1,	... 1 stroke is executed per 1 pulse.
With a factor of 2,	... 2 strokes are executed per 1 pulse.
With a factor of 25,	... 25 strokes are executed per 1 pulse.

\*\* Explanation of reduction

With a factor of 1,	... 1 stroke is executed per 1 pulse.
With a factor of 0.5,	...1 stroke is executed after 2 pulses.
With a factor of 0.1,	...1 stroke is executed after 10 pulses.
With a factor of 0.75,	...1 stroke is executed once after 2 pulses, then 1 stroke is executed after 1 pulse two times, and then again 1 stroke after 2 pulses etc.



*If a remainder is obtained when dividing by the factor, then the device adds the remainders together. As soon as this sum reaches or exceeds "1", the pump executes an additional stroke. Therefore on average during the metering operation, the resultant number of strokes precisely matches the factor.*

## Non-processed pulses

The number of received pulses, which could not yet be processed, is stored by the device in the stroke memory, if it was activated. When the *[STOP/START]* key is pressed or the "Pause" function is activated, the stroke memory is deleted. You can avoid this with the "Memory" function extension:

## "Memory" function extension

Additionally, you can activate the "Memory" function extension (Identifier "m"). When "Memory" is activated, the pump adds up the remaining strokes, which could not be processed, up to the maximum capacity of the stroke memory of 99,999 strokes. If this maximum capacity is exceeded, the pump goes into fault mode.

## 8.5.4 "Analog" operating mode settings

The *'ANALOG'* menu is available under *'Analog'* mode in the *'Settings'* menu. The stroke rate is controlled using an analog current signal via the "External control" terminal. The secondary display "Signal current" indicates the incoming current.

You can select three types of current signal processing:

- *'Standard'* ( *'0 - 20 mA'* or *'4 - 20 mA'* )
- *'Extended'* ( *'Curve type'* )

### Standard

#### 0 - 20 mA

At 0 mA the pump is stationary -

At 20 mA the pump works at the maximum stroke rate.

Between these values, the stroke rate is proportional to the current signal.

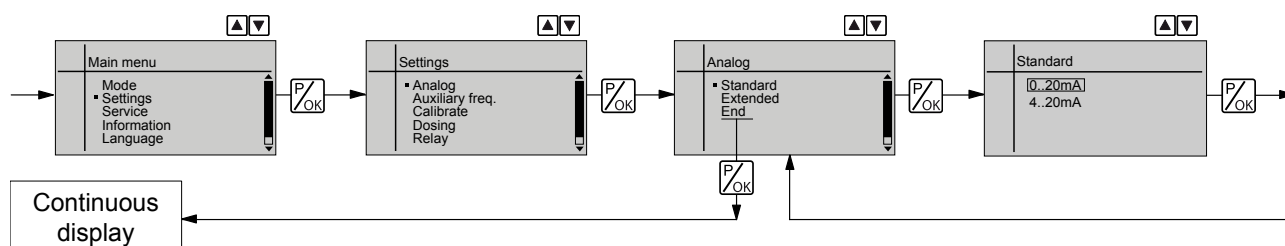

#### 4 - 20 mA

At 4 mA the pump is stationary -

At 20 mA the pump works at the maximum stroke rate.

Between these values, the stroke rate is proportional to the current signal.

For current signals less than 3.8 mA a fault message appears and the pump stops (e.g. if a cable has broken).



*The maximum stroke rate can only be reduced under 'Extended' processing types, not under 'Standard' processing types.*

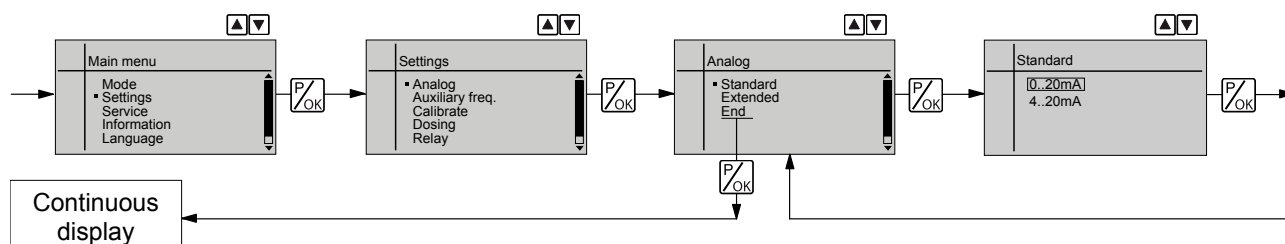

Extended

Under 'Extended' - 'Curve type' processing types, you can freely program the pump behaviour.

There are 3 curve types:

- 'Linear'
- 'Lower sideband' (lower sideband)
- 'Upper sideband' (upper sideband)

**i** The following applies to all three curve types:  
 The smallest processable difference between I1 and I2 is 4 mA ( $\|I1-I2\| \geq 4 \text{ mA}$ ).

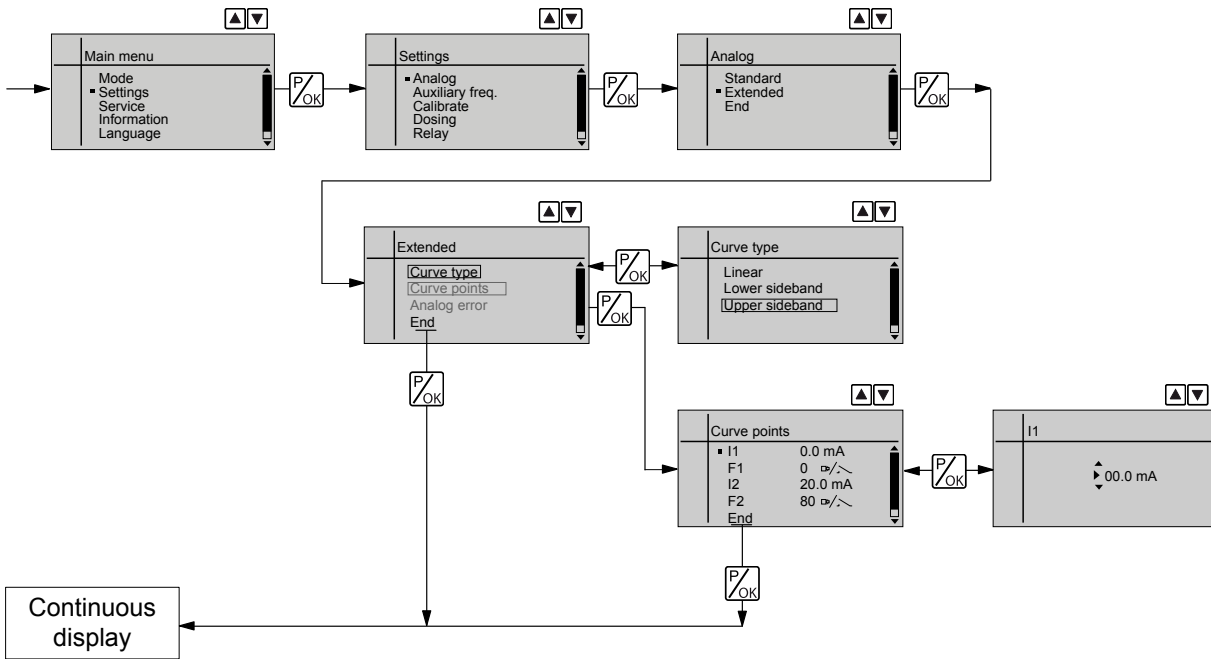

**'Linear'**

The symbol 'Linear' appears on the LCD screen. You can enter any stroke rate- behaviour of the pump proportional to the current signal. For this purpose, enter any two points P1 (I1, F1) and P2 (I2, F2) (F1 is the stroke rate at which the pump is to operate at current I1, F2 is the stroke rate at which the pump is to operate at current I2...); this defines a straight line and thus the behaviour is specified:

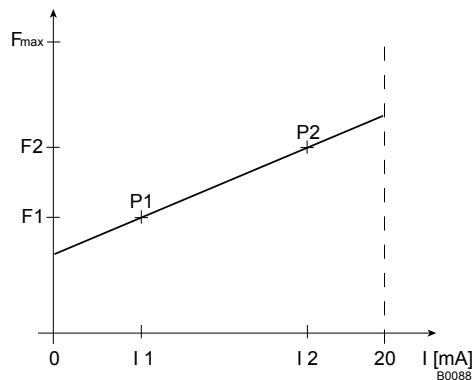

Fig. 29: Rate(frequency)-Current Diagram for Linear control



Plot a diagram similar to the one above - with values for ( $I_1$ ,  $F_1$ ) and ( $I_2$ ,  $F_2$ ) – so that you can set the pump as desired!

### 'Lower sideband'

Using this processing type, you can control a metering pump using the current signal as shown in the diagram below.

However, you can also control two metering pumps for different feed chemicals via a current signal (e.g. one acid pump and one alkali pump using the signal of a pH sensor). To do this, you must connect the pumps electrically in series.

The "Lower sideband" symbol appears in the LCD display. Below  $I_1$ , the pump works at a rate of  $F_1$  - above  $I_2$  it stops. Between  $I_1$  and  $I_2$  the stroke rate varies between  $F_1$  and  $F_2$  in proportion to the signal current.

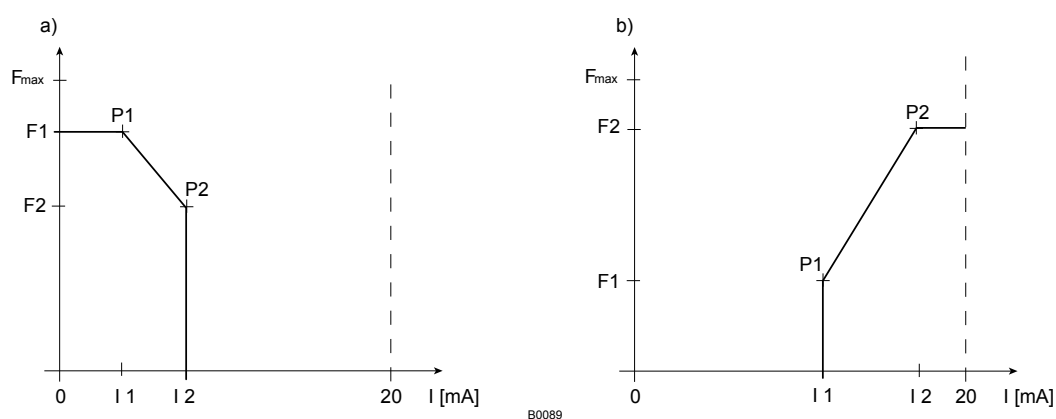

Fig. 30: Frequency-current diagram for a) Lower sideband, b) Upper sideband

### 'Upper sideband'

Using this processing type, you can control a metering pump using the current signal as shown in the diagram above.

However, you can also control two metering pumps for different feed chemicals via a current signal (e.g. one acid pump and one alkali pump using the signal of a pH sensor). To do this, you must connect the pumps electrically in series.

The "Upper sideband" symbol appears in the LCD display. Below  $I_1$ , the pump is stationary - above  $I_2$  the pump works at rate  $F_2$ . Between  $I_1$  and  $I_2$  the stroke rate varies between  $F_1$  and  $F_2$  in proportion to the signal current.

### Fault processing

Under menu option 'Analog error' you can activate error processing for processing type 'Curve'. For current signals below 3.8 mA, a fault message appears and the pump stops.

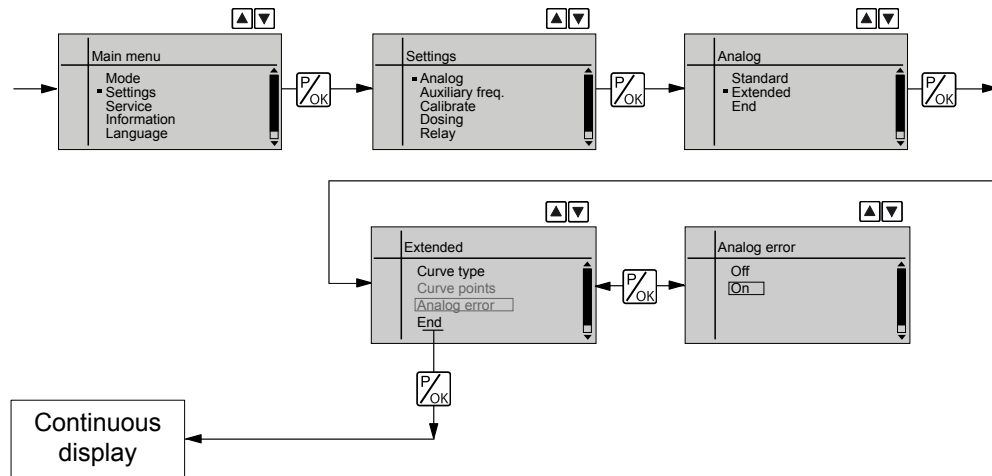

## 8.6 Programmable function settings ("Settings" menu )

Setting menus are available in all operating modes in the menu "SETTINGS" for the following programmable functions:

- Auxiliary frequency (menu 'AUX')
- Flow (menu 'FLOW') (only available if a dosing monitor is connected)
- Calibrate (menu 'CALIBRATE')
- Metering (menu 'METERING')
- Relay (menu 'RELAY') (only available if a relay is fitted)
- System (menu 'SYSTEM')

### 8.6.1 Settings for the "Auxiliary frequency" function (AUX menu)

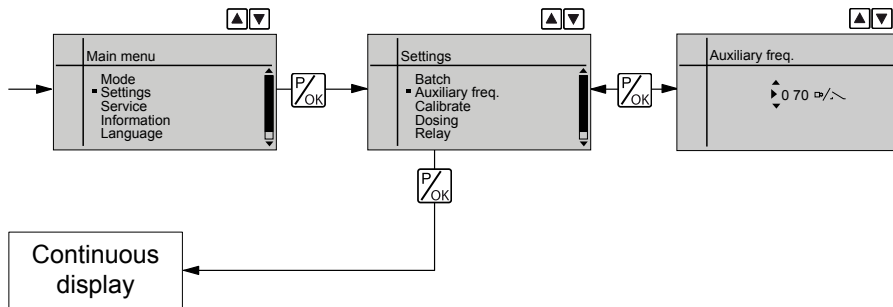

The programmable function 'Auxiliary frequency' facilitates the switchover to an auxiliary stroke rate, which can be set in the 'Auxiliary freq.' menu. It can be activated via the "External control" terminal. If the auxiliary frequency is being used, then the identifier "Aux" appears on the LCD screen.

This 'auxiliary frequency' has priority over the stroke rate, which is specified by the currently selected operating mode - see also the chapter "Function description" - "Hierarchy of operating modes".

## 8.6.2 Settings for the “Calibrate” function (CALIBRATE menu)

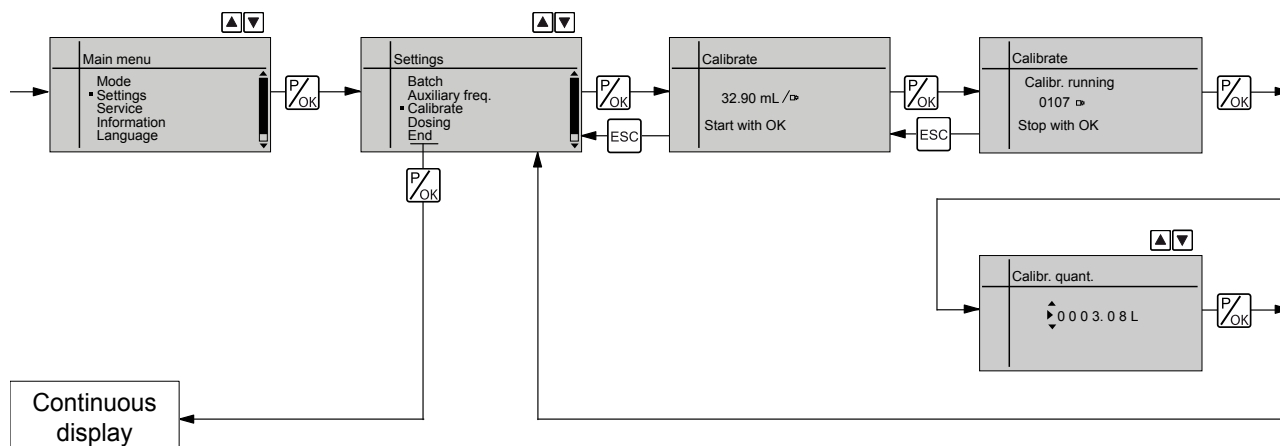

The pump can also be operated in the calibrated state. In this case, the corresponding continuous displays then indicate the metering volume or the capacity directly.



### Accuracy of the calibration

The calibration will not be accurate, if these conditions are not adhered to:

- Operate with at least 30 % stroke length.
- The pump should operate at maximum frequency.

## Calibrate



### WARNING!

If the feed chemical is dangerous, take appropriate safety precautions when executing the following calibration instructions.

Observe the safety data sheet for the feed chemical!

1. ➔ Lead the suction hose into a measuring cylinder containing the feed chemical - the discharge hose must be installed in a permanent manner (operating pressure, ...!).
2. ➔ Prime using the feed chemical (simultaneously press the two [arrow keys]), should the suction hose be empty.
3. ➔ Record the level in the measuring cylinder.
4. ➔ To set the volume unit, follow the menu path 'Settings → System → Units'.
5. ➔ Using the [arrow keys], select the correct units and confirm by pressing the [P/OK] key.
6. ➔ Select the 'CALIBRATE' menu and then use the [P/OK] key to change to the first menu option.
7. ➔ To start the calibration, press the [P/OK] key. The next menu option, 'Calib. running' appears, the pump starts to pump and indicates the stroke rate (the pump works at the stroke rate, which is set under 'MANUAL').
8. ➔ After a reasonable number of strokes (e.g. 200), stop the pump by pressing the [P/OK] key.
9. ➔ Determine the required metering volume (difference initial volume - residual volume).
10. ➔ Enter this volume in the menu option which appears and then press the key [P/OK] - the pump changes to the main menu.

11. ▶ Select the option 'End' and then press the key [P/OK] - the pump changes to a continuous display.

⇒ The pump is calibrated.

The corresponding continuous displays indicate the calibrated values.

### 8.6.3 Settings for the "Metering" function (DOSING menu)

The "Dosing" menu has the following sub-menu:

1 - 'Dosing profile'

#### 8.6.3.1 Settings in the sub-menu "Dosing"

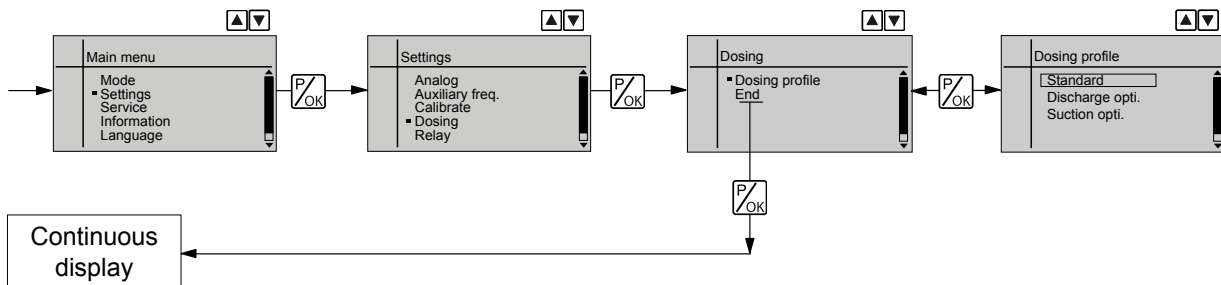

Under 'Dosing → Dosing profile' you can precisely match the pump metering flow over time against the requirements of the particular application, see Chapter "Function Description".

#### Discharge opti.

Under 'Dosing profile' - 'Discharge opti.', the discharge stroke is elongated, the suction stroke is executed as quickly as possible. This setting is suitable for example for those applications that require optimum mixing ratios and as continuous as possible chemical mixing.

#### Suction opti.

Under 'Dosing profile' - 'Suction opti.', the suction stroke is elongated as much as possible, which makes possible a precise and problem-free dosing of viscous and gaseous media. This setting should also be chosen to minimise the NPSH value.



### 8.6.4 Settings for the “Dosing monitor” function (DOSING MONITOR menu)

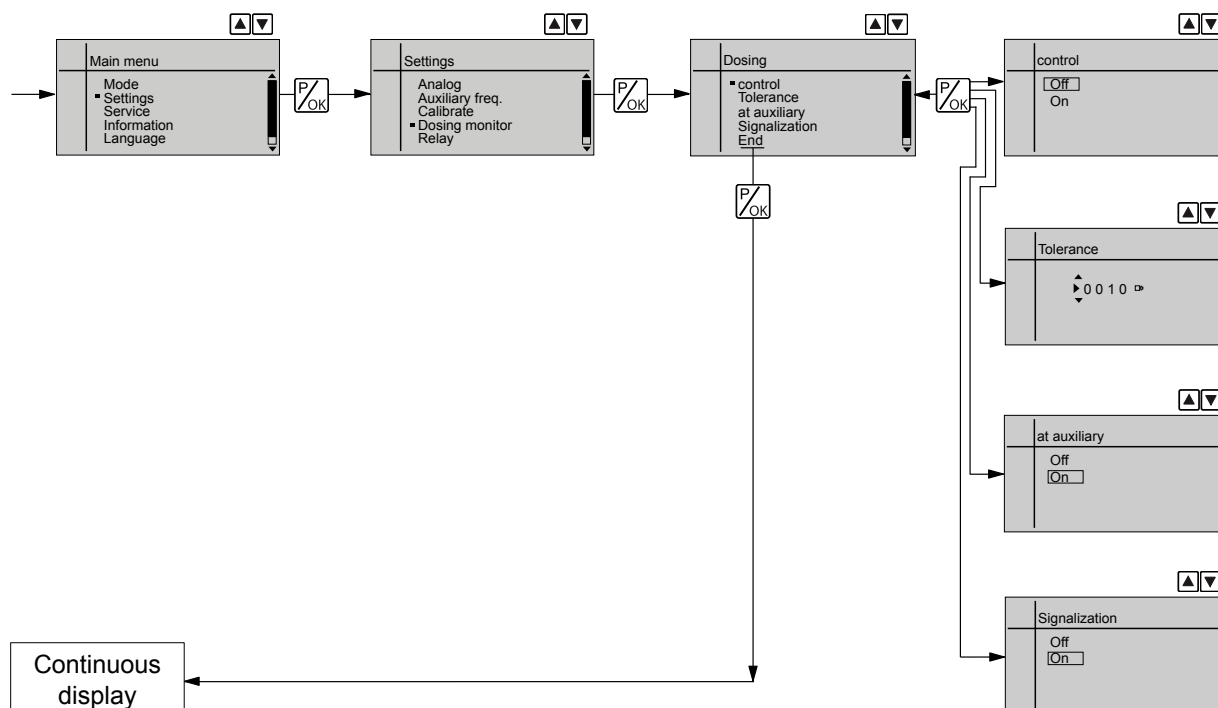

The menu 'Dosing monitor' only appears if a dosing monitor is connected to the "dosing monitor" terminal. The dosing monitor records the individual pressure surges of the pump at the discharge connector during pulsed metering and reports them back to the pump. In the event that this feedback message remains missing in a sequence as often as set in the menu 'Dosing monitor' under 'Tolerance' (due to a failure or too low a metering level), then this function stops the pump.

The last menu option 'Signalization' provides the choice, of whether this case should lead to an 'Error' or a 'Warning'.

The function 'Dosing monitor' can be deactivated under 'Control'.

The function 'Dosing monitor' can be deactivated for the operating mode 'Auxiliary freq.'.

### 8.6.5 Settings for the “Relay” function (RELAY menu)

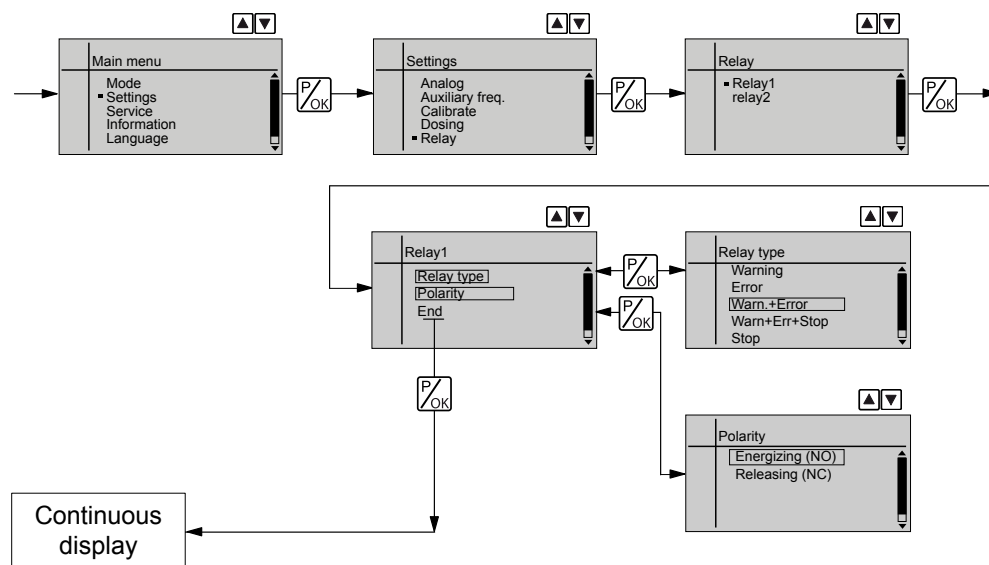

Using the 'Relay' programmable function, you can match the pump relays to your requirements.

You can reprogram the relays using the 'Relay' function in an almost unlimited way.

You can set whether the respective relay is to switch due to a warning alert, a fault alert, a pump stroke or to a triggering event of the timer:

### Selectable behaviour types

Setting in the 'Relay' menu	Effect
Warning	The relay switches upon a warning alert (yellow LED*).
Error	The relay switches upon a fault alert (red LED*).
Warn.+Error	The relay switches upon a warning alert (yellow LED*) or a fault alert (red LED*).
Warn+Err+Stop	The relay switches upon a warning alert (yellow LED*) or a fault alert (red LED*) or a stop (key [STOP/START] or pause or bus command).
Stop	The relay switches upon a stop (key [STOP/START] or pause or command from an optional module).
Pacing relay	The relay switches every stroke.
Option	The relay has the option of which module was plugged in (e.g. timer).

\* see "Troubleshooting" chapter

You can also indicate how the respective relay should behave as soon as it switches. You can change this via the setting 'ENERGIZING (NO)' / 'RELEASING (NC).'



*The setting option for the 'Relay' function only exists if a relay is present.*

### Allocations for the relay combinations

Display text	"Relay 1"	"Relay 2"
	(Mechanical relay)	Semiconductor relay)
Warning	Warning relay	Warning relay
Error	Fault indicating relay	Fault indicating relay
Warn.+Error	Warning and fault indicating relay	Warning and fault indicating relay
Warn.+Error+Stop	Warning, fault indicating and cut-off relay	Warning, fault indicating and cut-off relay
Stop	Cut-off relay	Cut-off relay
Pacing relay	-	Pacing relay

### 8.6.6 Settings for the "Analog output" function (ANALOG OUTPUT menu)

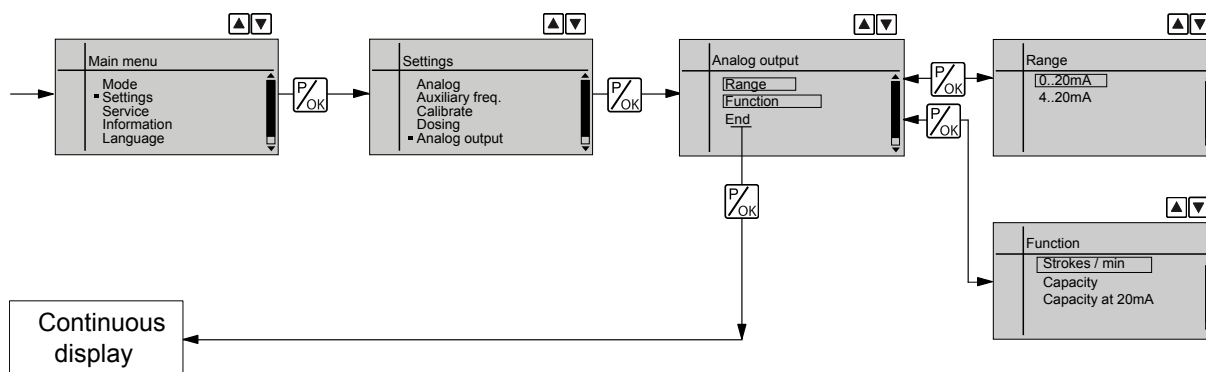

Using the "Analog output" programmable function, you can match the pump current output signal (optional) to your requirements.

The signal I of the current output signal one of the three following variables:

- Strokes / min
- Capacity (= current, calculated capacity)
- Capacity at 20 mA (= capacity, value adjustable at 20 mA)

In the "Stop" or "Pause" states (either because of a fault or operation) or "Pause" the current output transmits a current of 4 mA or 0 mA.

The signal for the current, calculated capacity is calculated by the pump according to the following formula (here for the range 4...20 mA):

$$I(4...20) = 16 \times (f/f_{max}) \times (L/100) + 4$$

with

I - Output current in mA

f - Stroke rate in strokes/min

L - Stroke length in %

f<sub>max</sub> - Maximum stroke rate in strokes/min

In the 'Contact' and 'Batch' operating modes, f is the stroke rate which is set in the "Stroke rate" continuous display.

### 8.6.7 Settings for the "Diaphragm break" function (DIAPHRAGM BREAK menu)

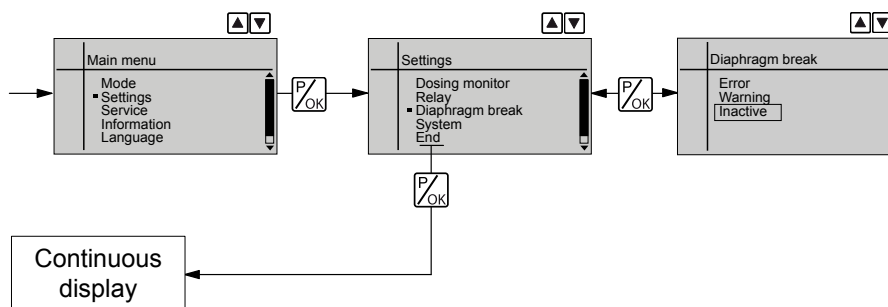

Using the "Diaphragm break" programmable function, you can match the behaviour under fault conditions of the pump to your requirements, provided an electrical membrane rupture sensor is connected.

There is a choice, of whether a membrane rupture should lead to an 'Error' or a 'Warning'. If 'Inactive' is set, the pump does not react to a diaphragm rupture, however the symbol **dia** indicates that an electrical membrane rupture sensor is connected.

## 8.6.8 Settings in the "System" menu" (SYSTEM menu)

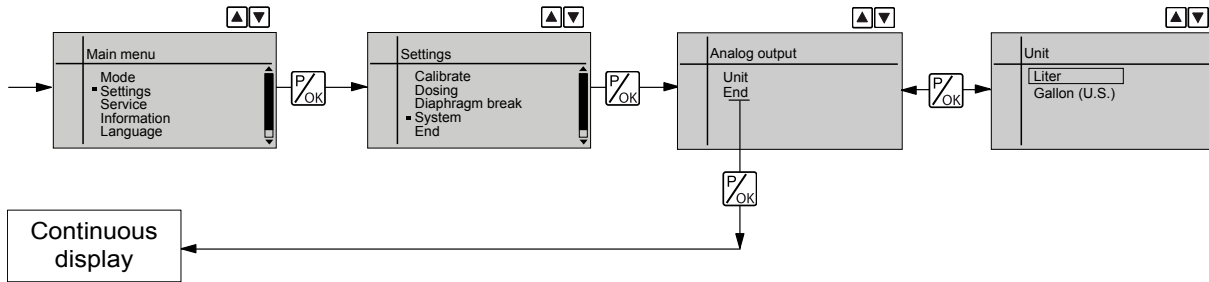

In the 'System' menu you can select whether the pump uses 'Liter' or 'Gallon (US)' as the 'Unit'.

## 8.7 Service (SERVICE menu)

The following can be carried out from this menu:

- 1 - 'Clear counters'
- 2 - Set contrast (Menu 'Display')
- 3 - 'HMI logout'
- 4 - Set safety settings for operating menu ('Safety' menu)

### 8.7.1 Clear counters (CLEAR COUNTERS menu)

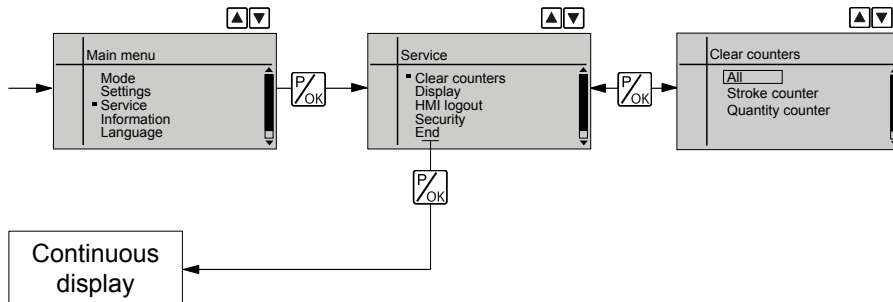

In the 'CLEAR COUNTERS' menu, you can either delete the stored total number of strokes ('Stroke counter') or the total litres ('Quantity counter') (= reset to "0") or both together :

- 'All'
- 'Stroke counter' (total number of strokes)
- 'Quantity counter' (total litres)
- 'Memory' (remaining strokes) (only with 'Batch' and 'Contact')

To do this simply quit the menu by quickly pressing the key [P/OK] key.

The variables have increased since commissioning of the pump, the last calibration or the last deletion.

## 8.7.2 Adjusting the Display (DISPLAY menu)

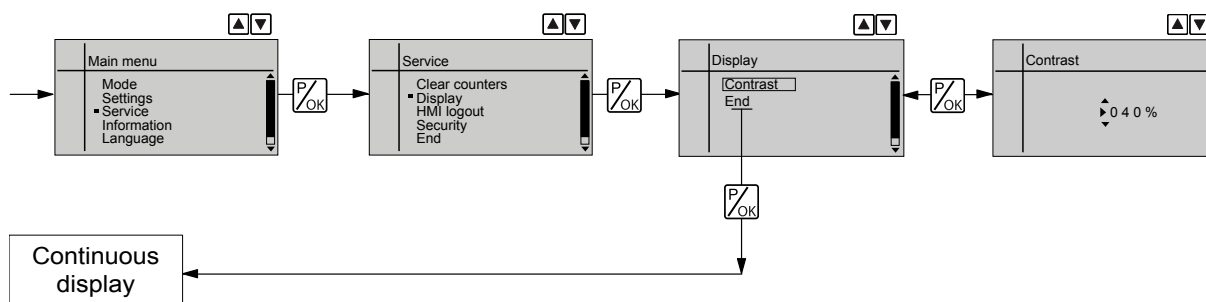

In the 'DISPLAY' sub-menu the LCD screen contrast can be changed using the [Arrow keys].

## 8.7.3 HMI logout

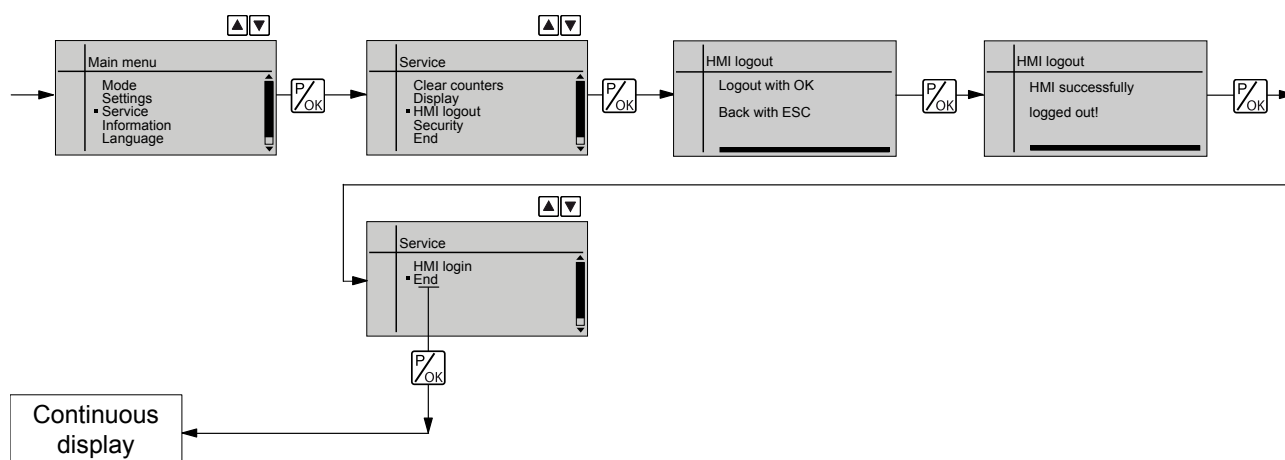

In this menu you can log into and out of the pump HMI:

To logout run through the menu above. Thereafter the HMI can be removed from the pump.

Logging on takes place automatically whenever the HMI cable is connected to the CAN port.

If the HMI must be formally logged into: Logging on via the menu occurs in exactly the same way as logging off.

If the HMI is disconnected from the CAN bus, without first logging it off, the pump remains stationary.



### WARNING!

An on/off switch may not be fitted on the pump, dependent on the identity code and installation.



To be able to switch off the pump (to a zero-volts state) independently from the entire installation (e.g. for repair), use an electrical isolating device in the mains supply cable, e.g. a mains switch or a plug / socket combination. Clearly identify this isolating device as such.

### 8.7.4 Security (SECURITY menu)

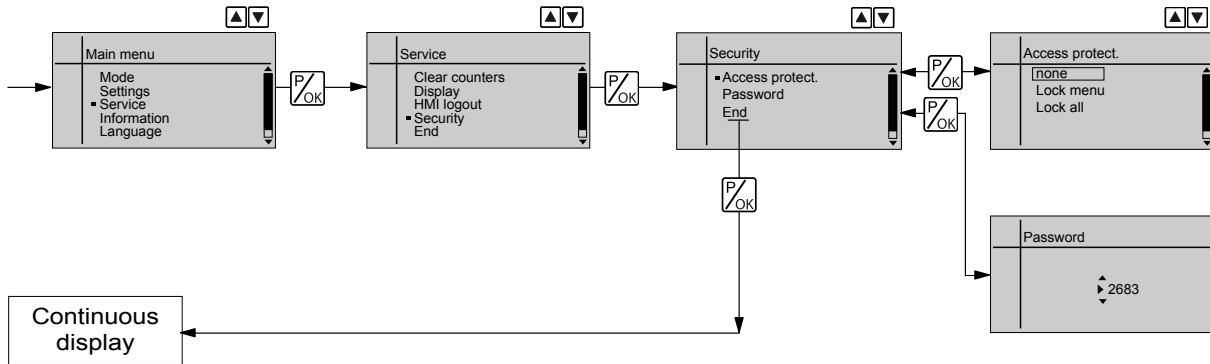

In the 'SECURITY' menu, you can enter for which parts of the adjustment options an 'Access protect' should apply and a 'password' be specified.

**i** This menu itself is ALWAYS password protected.  
As supplied the 'password' is "1111".

#### 8.7.4.1 Access protect.

In the first menu option, you can either set 'None' ('Access protect') or 'Lock menu' or 'Lock all' :

- Select 'None', to clear a set 'Access protect'.
- Select 'Lock menu' to lock the adjustment mode (point ① in the overview "Operating/setting diagram", in the appendix).
- Select 'Lock all' to lock the adjustment option for the directly adjustable variables in the continuous displays and to lock the stroke length (point ② in the overview "Operating/setting diagram", in the appendix), in addition to the adjustment mode.

**i** If an Access protect is then set after 1 minute a padlock will appear instead of the "i" in the top left of the continuous display if in the meantime no key has been pressed.

#### 8.7.4.2 Password

In this menu enter the number you want to use as a password.

The password applies for both locks.

#### 8.7.4.3 Using Access protect and Password

##### Test

To test whether the menu is locked, press the [P/OK] key for 2 s.

If you try to change into a locked area, a 'Password' request appears.

##### Overriding the Access protect.

To override the Access protect, enter the 'Password' using the [arrow keys] and press the [P/OK] key.

### Changing the stroke length variable

In the stroke adjustment dial has been turned, the padlock flashes, the pump stops and a fault alert and key appear. If you enter the code, the pump continues metering and the fault alert clears.

## 8.8 Information about the pump (INFORMATION menu)

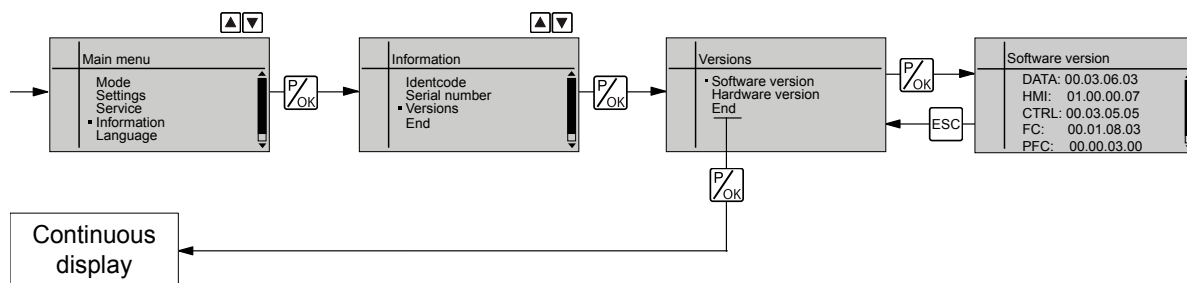

In the "Info" sub-menu you can read off the following identification numbers:

- Identity code
- Serial number
- Software versions
- Hardware versions

## 8.9 Set language (LANGUAGE menu)

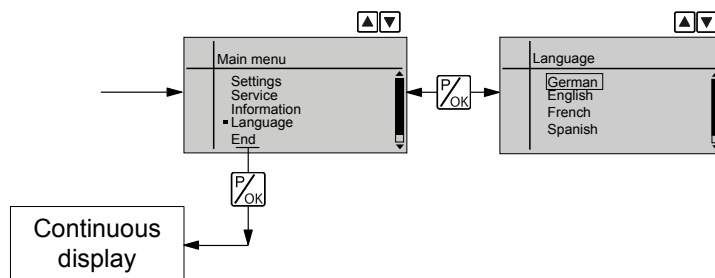

In the 'LANGUAGE' menu, you can select the desired operating language.

## 9 Operation



**WARNING!**

**Danger of electric shock**

Incompletely installed electrical options can allow moisture into the inside of the housing.

- Knock-out openings in the pump housing must be equipped with matching modules or be sealed in a leak-tight manner.



**WARNING!**

**Danger of electric shock**

A mains voltage may exist inside the pump housing.

- If the pump housing has been damaged, you must disconnect it from the mains immediately. It may only be returned to service after an authorised repair.



**CAUTION!**

Do not overexpand the spiral cable of the HMI.

It may be drawn up to 0.5 m, only.

This chapter describes all the operating options available to you if the pump is displaying a continuous display - in the top left of the display there is an "i".



- *For supplementary information, see the overviews "Control elements and key functions" in the chapter "Device overview and control elements" and "Operating/setting diagram" in the appendix.*
- *Also take note of the overview "Continuous displays" in the appendix. It shows which continuous displays are available in which operating mode and which variables are directly changeable in the relevant continuous display.*

### 9.1 Manual

Personnel:  Instructed personnel

#### Adjusting the stroke length

The stroke length is adjusted by the stroke length adjustment knob within a range of 0 ... 100 %. A stroke length of between 30 ... 100 %) is recommended to achieve the specified reproducibility.

The following operating options are available via the keys - see the next figure:

#### Stopping/starting the pump

Stop the pump: Press the *[STOP/START]* key.

Start the pump: press the *[STOP/START]* key again.

#### Starting batch

In 'Batch' operating mode: briefly press key *[P/OK]*.



**Changing to adjustment mode**

In continuous display if you keep the *[P/OK]* key pressed for 2 s, the pump switches into adjustment mode - see "Adjustment" chapter.

If under '*Service* → '*Security* → '*Access protect*' the selection '*Lock menu*' or '*Lock all*' was set, then after pressing the key *[P/OK]* the '*Password*' must first be entered.

**Checking adjustable values**

Each time you press the *[i/>]* key, you can see a different continuous display possibly mixed with error messages. The number of continuous displays depends on the identity code, the selected operating mode and the connected additional devices.

The same applies for auxiliary displays, which are accessed a longer single press of the key *[i/>]*.

**Change directly changeable variables**

To change a variable (see below) directly in the corresponding continuous display, press one of the *[arrow keys]*.

If under '*Service* → '*Security* → '*Access protect*' the selection '*Lock all*' was set, then after pressing the key *[P/OK]* the '*Password*' must first be entered.

The directly changeable variables are in detail:

**Stroke rate**

In operating modes '*Manual*', '*Contact*' and '*Batch*':

You can change the stroke rate in the "Stroke rate" continuous display.



*To change a precisely previously set feed rate (possibly specified in litres), there is an option of changing it via the stroke rate. As the stroke rate is digitally processed, there is no tolerance.*

*By contrast, changing via the stroke length interferes with the mechanical tolerance.*

**Capacity**

You can change the capacity once the pump has been calibrated in the "Capacity" continuous display.



*To change a precisely previously set feed rate (possibly specified in litres), there is an option of changing it via the capacity. As the capacity is digitally processed, there is no tolerance.*

*By contrast, changing via the stroke length interferes with the mechanical tolerance.*

**Factor**

Only in '*Batch*' mode: The factor is the number of strokes which are triggered upon an external pulse or pressing of key *[P/OK]*.

Other key functions:

**Priming**

Simultaneous pressing of the two *[arrow keys]* triggers the "Priming" function.

**Acknowledge errors**

Error displays are acknowledged by brief pressing of the *[P/OK]* key.

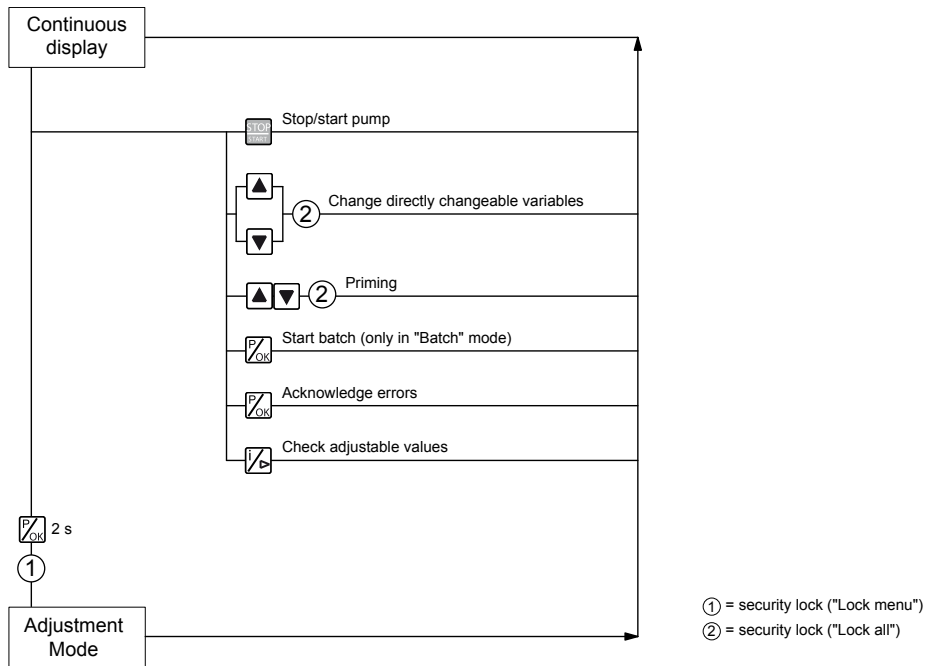

Fig. 31: Operating options with a locked operating menu

## 9.2 Remote operation

There is an option to control the pump remotely via a signal cable - refer to your system documentation and to the "Electrical Installation" chapter.

The pump can also be remotely controlled via PROFIBUS® (option). Supplementary instructions are available for this.

Or via an external CANopen bus. Supplementary instructions are available for this.

# 10 Maintenance

## Safety notes



### WARNING!

It is mandatory that you read the safety information and specifications in the "Storage, Transport and Unpacking" chapter prior to shipping the pump.



### CAUTION!

#### Warning of feed chemical spraying around

Feed chemical can spray out of the hydraulic components if they are manipulated or opened due to pressure in the liquid end and adjacent parts of the system.

- Disconnect the pump from the mains power supply and ensure that it cannot be switched on again by unauthorised persons.
- Depressurise the system before commencing any work on hydraulic parts.



### WARNING!

#### Warning of dangerous or unknown feed chemical

Should a dangerous or unknown feed chemical be used: It may escape from the hydraulic components when working on the pump.

- Take appropriate protective measures before working on the pump (e.g. safety glasses, safety gloves, ...). Observe the safety data sheet for the feed chemical.
- Drain and flush the liquid end before working on the pump.



### WARNING!

#### Danger of an electric shock

When working on the motor or electrical auxiliary equipment, there is a danger of an electric shock.

- Before working on the motor, take note of the safety instructions in its operating instructions!
- Should external fans, servomotors or other auxiliary equipment be installed, these should also be disconnected and checked that they are voltage free.



*Place a spare parts kit in stock ready for maintenance work. You can find order numbers in the appendix under "Ordering information" - "Spare parts kits".*



*Third party spare parts for the pumps may lead to problems when pumping.*

- Use only original spare parts.
- Use the correct spare part kits. In case of doubt, refer to the exploded views and ordering information in the appendix.

## Standard liquid ends:

Interval	Maintenance work	Personnel
Quarterly*	<ul style="list-style-type: none"> <li>■ Check that the metering lines are fixed firmly to the liquid end.</li> <li>■ Check that the suction valve and discharge valve are correctly seated.</li> <li>■ Check that the dosing head screws are tight</li> <li>■ Check the condition of the metering diaphragm - see ↗ <i>'Check the condition of the metering diaphragm' on page 68.</i></li> <li>■ Check that the flow is correct: Allow the pump to prime briefly.</li> <li>■ Check that the electrical connections are intact</li> </ul>	Technical personnel

\* Under normal loading (approx. 30 % of continuous operation).

Under heavy loading (e.g. continuous operation): shorter intervals.

## Check the condition of the metering diaphragm

The metering diaphragm is a wear part, the service life of which is dependent upon the following parameters:

- System back pressure
- Operating temperature
- Feed chemical properties

When using abrasive feed chemicals, the diaphragm service life is reduced. In such cases, more frequent checking of the diaphragm is recommended.

## Tightening torques

Data	Value	Unit
Tightening torques for dosing head screws:	4.5 ... 5.0	Nm

# 11 Repairs

## Safety notes



### WARNING!

It is mandatory that you read the safety information and specifications in the "Storage, Transport and Unpacking" chapter prior to shipping the pump.



### CAUTION!

#### Warning of feed chemical spraying around

Feed chemical can spray out of the hydraulic components if they are manipulated or opened due to pressure in the liquid end and adjacent parts of the system.

- Disconnect the pump from the mains power supply and ensure that it cannot be switched on again by unauthorised persons.
- Depressurise the system before commencing any work on hydraulic parts.



### WARNING!

#### Warning of dangerous or unknown feed chemical

Should a dangerous or unknown feed chemical be used: It may escape from the hydraulic components when working on the pump.

- Take appropriate protective measures before working on the pump (e.g. safety glasses, safety gloves, ...). Observe the safety data sheet for the feed chemical.
- Drain and flush the liquid end before working on the pump.

## 11.1 Cleaning valves



*Unsuitable spare parts for the valves may lead to problems for the pumps.*

- *Only use new components that are especially adapted to fit your valve (both in terms of shape and chemical resistance).*
- *Use the correct spare part kits. In case of doubt, refer to the exploded views and ordering information in the appendix.*

Personnel:  Technical personnel

## Repairing ball valves



### CAUTION!

#### Warning of personal injury and material damage

Feed chemical may escape from the liquid end, for example, if ball valves not repaired correctly.

- Only use new components which fit your valve - both in terms of shape and chemical resistance!
- Pay attention to the flow direction of the discharge and suction connectors when fitting the valve.

1. ➤ Unscrew the valve from the liquid end.
2. ➤ Screw the valve cap (5) on its suction side - see diagram.
3. ➤ Carefully remove the parts from the valve body (2).
4. ➤ Replace the worn parts.
5. ➤ Clean the remaining parts.
6. ➤ Check all parts.
7. ➤ Insert the valve ball (3 and the valve seat (4).
8. ➤ Screw on the valve cap (5).

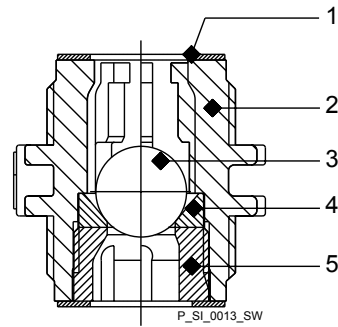

*Fig. 32: Simple cross-section through ball valve*

- 1 Flat seal
- 2 Valve body
- 3 Valve ball
- 4 Valve seat
- 5 Valve cap

## 11.2 Replacing the metering diaphragm



Third party spare parts for the pumps may lead to problems when pumping.

- Use only original spare parts.
- Use the correct spare part kits. In case of doubt, refer to the exploded views and ordering information in the appendix.

Personnel: ■ Technical personnel

### Requirements:

- If necessary take protective measures.
  - Observe the safety data sheet for the feed chemical.
  - Depressurise the system.
1. ➤ Drain the liquid end: Place the liquid end on its head and allow the feed chemical to run out; flush out with a suitable medium; flush the liquid end thoroughly when using hazardous feed chemicals!
  2. ➤ With the pump running, move the stroke adjustment dial to the stop at 0 % stroke length.
    - ⇒ The drive axle is now difficult to turn.
  3. ➤ Switch off the pump.
  4. ➤ Unscrew the hydraulic connectors on the discharge and suction side.
  5. ➤ Unscrew the diaphragm rupture sensor from the dosing head.
  6. ➤ Remove the 6 screws on the dosing head.
  7. ➤ Remove the dosing head.
  8. ➤ Check the condition of the diaphragm rupture sensor - see  'Checking the condition of the diaphragm rupture sensor' on page 73.
  9. ➤ Loosen the diaphragm from the drive axle with a gentle backwards turn in the anti-clockwise direction.
  10. ➤ Completely unscrew the diaphragm from the drive axle.
  11. ➤ Tentatively screw the new diaphragm anticlockwise up to the stop on the drive axle.
    - ⇒ The diaphragm now is now seated against the stop of the thread while the diaphragm flap is within the tolerance range.

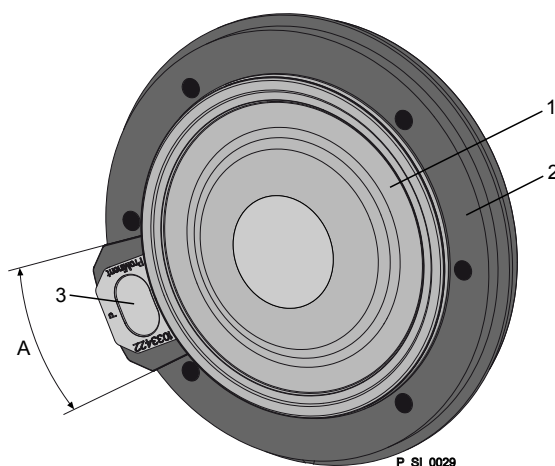



Fig. 33: Tolerance range of the flap on the backplate

- 1 Diaphragm
- 2 Backplate
- 3 Flap

### A Tolerance range

- 12.** ▶ Should this not work, remove dirt or swarf out of the thread and screw the diaphragm correctly onto the drive axle this time.
  - ⇒ If this is still unsuccessful, contact ProMinent-ProMaqua customer service.
- 13.** ▶ Place the dosing head with the screws onto the diaphragm - the suction connector must be pointing downwards in the pump's fitting position.
- 14.** ▶ Tighten the screws gently to start with.
- 15.** ▶ Screw the diaphragm rupture sensor into the dosing head.
- 16.** ▶ Start up the pump and adjust the stroke length to 100 %.
- 17.** ▶ Stop the pump and tighten the screws crosswise. Tightening torque - see  'Tightening torques' on page 68.
- 18.** ▶ Start the pump and at maximum pressure, check for leaks.



#### **CAUTION!**

##### **Warning of escaping feed chemical**

The liquid end may leak should it not be possible to check the tightening torque of the screws.

- Check the tightening torque of the screws after 24-hours of operation!
- With PP, PC and TT dosing heads also re-check the tightening torques quarterly!



## Checking the condition of the diaphragm rupture sensor

1. If the inside of the diaphragm rupture sensor has become damp or dirt has penetrated it: replace.

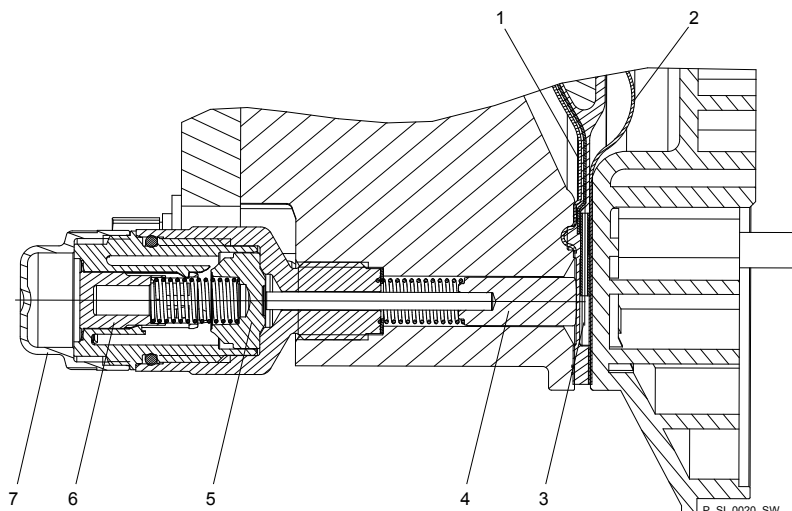

Fig. 34: Section through the Sigma diaphragm rupture warning system ("Visual break indicator" version)

- 1 Working layer ( $\hat{=}$  operating diaphragm)
  - 2 Safety layer ( $\hat{=}$  safety diaphragm)
  - 3 Flap
  - 4 Piston
  - 5 Diaphragm rupture sensor
  - 6 Cylinder, red
  - 7 Cover, transparent
2. If the piston of the diaphragm rupture sensor - see Fig. 34, item 4 - should have become dirty or damp, clean both it and the hole in which it runs.
  3. Check whether it can move freely in the hole.
  4. Refit the clean diaphragm rupture sensor with the clean piston.
  5. Test the diaphragm rupture sensor.

### Optical diaphragm rupture sensor

1. Unscrew the transparent cover from the diaphragm rupture sensor.
2. Press the red cylinder into the diaphragm rupture sensor until it engages.
3. Press the piston on the other side of the diaphragm rupture sensor with a blunt, smooth object into the dosing head (approximately 4 mm) until it triggers.



#### CAUTION!

##### Feed chemical may escape

If the expandable flap of the diaphragm is damaged, then feed chemical can escape when there is a diaphragm rupture.

The piston must not be scratched, it must remain completely smooth so that during operation it does not damage the expandable flap of the diaphragm.

4. Press the red cylinder into the diaphragm rupture sensor again and repeat the test.
5. If it does not trigger both times, replace the membrane rupture sensor.

6. ➤ After a successful test, screw the transparent cover onto the diaphragm rupture sensor and then continue at the top by fitting the diaphragm.

**Electrical diaphragm rupture sensor**

1. ➤ Press the piston of the diaphragm rupture sensor with a blunt, smooth object into the dosing head (approximately 4 mm) until the monitor triggers alarm.



**CAUTION!**

**Feed chemical may escape**

If the expandable flap of the diaphragm is damaged, then feed chemical can escape when there is a diaphragm rupture.

The piston must not be scratched, it must remain completely smooth so that during operation it does not damage the expandable flap of the diaphragm.

2. ➤ Repeat the test.
3. ➤ If the monitor does not trigger an alarm both times, replace the membrane rupture sensor.
4. ➤ After a successful test, continue at the top by fitting the diaphragm.

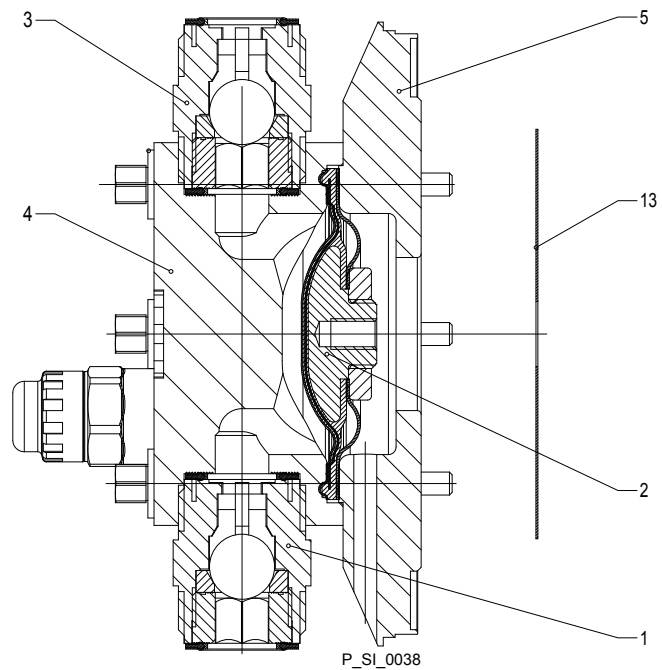

*Fig. 35: Cross-section through the liquid end*

- 1 Suction valve
- 2 Metering diaphragm
- 3 Discharge valve
- 4 Dosing head
- 5 Backplate
- 13 Safety diaphragm

**Tightening torques**

Data	Value	Unit
Tightening torques for dosing head screws:	4.5 ... 5.0	Nm

## 12 Troubleshooting

### Safety notes



#### WARNING!

##### Warning of dangerous or unknown feed chemical

Should a dangerous or unknown feed chemical be used: It may escape from the hydraulic components when working on the pump.

- Take appropriate protective measures before working on the pump (e.g. safety glasses, safety gloves, ...). Observe the safety data sheet for the feed chemical.
- Drain and flush the liquid end before working on the pump.



#### CAUTION!

##### Warning of feed chemical spraying around

Feed chemical can spray out of the hydraulic components if they are manipulated or opened due to pressure in the liquid end and adjacent parts of the system.

- Disconnect the pump from the mains power supply and ensure that it cannot be switched on again by unauthorised persons.
- Depressurise the system before commencing any work on hydraulic parts.

### 12.1 Faults without a fault alert

Fault description	Cause	Remedy	Personnel
Pump does not prime in spite of full stroke motion and bleeding	Minor crystalline deposits on the ball seat due to the valves drying out	Take suction hose out of the storage tank and thoroughly flush out the liquid end	Technical personnel
	Major crystalline deposits on the ball seat due to the valves drying out	Dismantle the valves and clean them - refer to the "Overhaul" chapter.	Technical personnel
Fluid is escaping from the backplate	The screws in the dosing head are too loose	Tighten the screws in the dosing head in a diagonal pattern - refer to the "Repairs" chapter for tightening torque.	
	The metering diaphragm is not tight	Replace the diaphragm - refer to the "Overhaul" chapter.  If a diaphragm rupture has been indicated, clean the diaphragm rupture reporter, refer to the "Overhaul" chapter.	Technical personnel
The CAN LED flickers after connection of the HMI to the pump.	The software versions of the pump and HMI are different.	Wait. In the log term, arrange for service to update the pump software.	
Green LED display (operating display) does not light up	The wrong mains voltage or no mains voltage is connected	Connect the pump correctly to the specified mains voltage - according to the specification on the nameplate.	Electrician

### 12.2 Fault alerts

Red LED "Fault indicator" lights up.

Fault description	Cause	Remedy	Personnel
The "Level" symbol  appears flashing on the LCD screen, plus the error message 'Level error' E-33-3 and the pump stops.	The liquid level in the storage tank has reached "liquid level low 2nd stage".	Fill the storage tank	Technical personnel
The symbol "External"  MEM appears flashing on the LCD screen plus the error message 'Memory overflow' E-34-3 and the pump stops.	The stroke memory has overflowed.	Rectify the cause, then press the [P/OK] key (think through the consequences for the process!).	Technical personnel
The symbol $i < 4mA$ appears flashing on the LCD screen plus the error message 'Under 4mA' E-35-3 and the pump stops.	The pump is in 'Analog' 'operating mode', a fault behaviour has been programmed in the 'ANALOG' menu and the control current has fallen below 4 mA.	Clear the cause of the low control current or	Technical personnel
The symbol $i > 20mA$ appears flashing on the LCD screen plus the error message 'Under 20 mA' E-36-3 and the pump stops.	The pump is in 'Analog' 'operating mode', a fault behaviour has been programmed in the 'ANALOG' menu and the control current has risen above 23 mA.	Clear the cause of the high control current or	Technical personnel
The symbol "Flow"  FLOW appears flashing on the LCD screen plus the error message 'Defective stroke dosing' E-37-3 and the pump stops.	The dosing monitor is not correctly connected.	Connect the dosing monitor correctly and Press the [P/OK] key.	Electrician
	The dosing monitor reported too few strokes, more than set in the 'FLOW' menu.	Press the [P/OK] key. Investigate and clear the cause	Technical personnel
The symbol "Membrane"  DIA appears flashing on the LCD screen and the error message 'Diaphragm break' E-38-3 and the pump stops.	The diaphragm is broken.	Replace the diaphragm and clean the diaphragm rupture sensor, refer to the "Repair" chapter.	Technical personnel
The symbol "Stroke length adjustment"  STRK appears flashing on the LCD screen plus the error message 'Stroke length mis-set' E-39-3 and the pump stops.	The stroke adjustment dial was rotated by more than 10 % while the menu was locked.	Turn the stroke adjustment dial back or enter the password.	Technical personnel
The symbol "Temperature"  FC appears flashing on the LCD screen plus the error message 'Temperature FC' E47-4 and the pump stops.	The pump is overloaded.	Rectify the cause, then press the [P/OK] key (think through the consequences for the process!).	Technical personnel
	The temperature is too high.	Rectify the cause, then press the [P/OK] key (think through the consequences for the process!).	Technical personnel
The symbol "Overpressure" $p+ FC$ appears flashing on the LCD screen plus the error message 'Overload FC' E48-4 and the pump stops.	A constriction or a closed shut-off valve on the discharge side.	Open the shut-off valve or clear the constriction, then press the [P/OK] key (think through the consequences for the process!).	Technical personnel
The symbol "Mains"  PWR appears flashing on the LCD screen plus the error message 'Mains voltage' E51-5 and the pump stops.	No or incorrect mains voltage.	Connect the correct mains voltage.	Technical personnel

## 12.3 Warning Alerts

Yellow LED indicator "warning indicator" lights up:

Fault description	Cause	Remedy	Personnel
The "Level" symbol !⊕ appears flashing on the LCD screen, plus the error message 'Level warning' W1-3.	The liquid level in the storage tank has reached "liquid level low 1st stage".	Fill the storage tank	Instructed personnel
The symbol "Calibrate" !cal appears flashing on the LCD screen plus the error message 'Calibration warning' W2-3.	The stroke adjustment dial of the calibrated pump was rotated by more than 10 %.	Turn the stroke adjustment dial back or recalibrate the pump.	Instructed personnel
The "Flow" symbol !⊕ appears flashing on the LCD screen, plus the error message 'Defective strokes dosing' W3-3.	The dosing monitor is not correctly connected.	Connect the dosing monitor correctly and Press the [P/OK] key.	Electrician
	The dosing monitor reported too few strokes, more than set in the 'FLOW' menu.	Press the [P/OK] key. Investigate and clear the cause.	Technical personnel
The symbol "Membrane" !dia appears flashing on the LCD screen plus the error message 'Diaphragm break' W4-3.	The diaphragm is broken.	Replace the diaphragm and clean the diaphragm rupture sensor, refer to the "Repair" chapter.	Technical personnel
The "Stroke length adjustment" symbol !⊙ appears flashing on the LCD screen, plus the error message 'Stroke length mis-set' W5-3.	The stroke adjustment dial was rotated by more than 10 % while the menu was locked.	Turn the stroke adjustment dial back or enter the code.	Technical personnel
The symbol "Overload" !p+ appears flashing on the LCD screen plus the error message 'Overload FU' W6-4.	A constriction or a closed shut-off valve on the discharge side.	Open the shut-off valve or rectify the constriction.	Technical personnel
The "Temperature" symbol !⊖ appears flashing on the LCD screen, plus the error message 'Temperature FU' W7-4.	The frequency converter is overloaded.	Rectify the cause, then press the [P/OK] key (think through the consequences for the process!).	Technical personnel
	The temperature is too high.	Rectify the cause, then press the [P/OK] key (think through the consequences for the process!).	Technical personnel
The "Temperature" symbol !⊖ appears flashing on the LCD screen, plus the error message 'Temperature PFC' W7-5.	The pump is overloaded.	Rectify the cause, then press the [P/OK] key (think through the consequences for the process!).	Technical personnel
	The temperature is too high.	Rectify the cause, then press the [P/OK] key (think through the consequences for the process!).	Technical personnel
The 'BUS' symbol ! appears flashing on the LCD screen, plus the error message 'CANopen pump' W8-3.	The HMI was connected to a CANopen pump.	Disconnect the HMI from the pump.	Technical personnel

## 12.4 All Other Faults

Please contact the responsible ProMinent branch or agency, see [www.prominent.de](http://www.prominent.de) - "Contact" - "Your contact worldwide" or as the case may be, the published by details of these operating instructions.

## 13 Decommissioning

### Decommissioning



**WARNING!**

**Danger of an electric shock**

When working on the motor or electrical auxiliary equipment, there is a danger of an electric shock.

- Before working on the motor, take note of the safety instructions in its operating instructions!
- Should external fans, servomotors or other auxiliary equipment be installed, these should also be disconnected and checked that they are voltage free.



**WARNING!**

**Danger from chemical residues**

There is normally chemical residue in the liquid end and on the housing after operation. This chemical residue could be hazardous to people.

- It is mandatory that the safety note relating to the "Storage, Transport and Unpacking" chapter is read before shipping or transporting the unit.
- Thoroughly clean the liquid end and the housing of chemicals and dirt. Adhere to the safety data sheet for the feed chemical.



**WARNING!**

**Warning of dangerous or unknown feed chemical**

Should a dangerous or unknown feed chemical be used: It may escape from the hydraulic components when working on the pump.

- Take appropriate protective measures before working on the pump (e.g. safety glasses, safety gloves, ...). Observe the safety data sheet for the feed chemical.
- Drain and flush the liquid end before working on the pump.



**CAUTION!**

**Warning of feed chemical spraying around**

Feed chemical can spray out of the hydraulic components if they are manipulated or opened due to pressure in the liquid end and adjacent parts of the system.

- Disconnect the pump from the mains power supply and ensure that it cannot be switched on again by unauthorised persons.
- Depressurise the system before commencing any work on hydraulic parts.





**CAUTION!****Danger of damage to the device**

The device can be damaged by incorrect and improper storage or transportation.

- Take into account the information in the "Storage, Transport and Unpacking" chapter if the system is decommissioned for a temporary period.

**(Temporary) decommissioning**

Personnel:  Technical personnel

1.  Disconnect the pump from the mains power supply.
2.  Depressurise and bleed the hydraulic system around the pump.
3.  Empty the liquid end by turning the pump upside down and allowing the feed chemical to run out.
4.  Flush the liquid end with a suitable medium - Observe the safety data sheet! Flush the dosing head thoroughly when using hazardous feed chemicals!
5.  Possible additional work - see chapter "Storage, Transport and Unpacking".

**Disposal**

Personnel:  Technical personnel

**CAUTION!****Environmental hazard due to incorrect disposal**

- Note the local guidelines currently applicable in your country, particularly in regard to electronic waste!

## 14 Technical data

### 14.1 Performance data

S1Cb

Type	Minimum pump capacity at maximum back pressure				Maximum stroke rate		Suction lift	Permissible priming pressure, suction side	Connector size
	bar	psi	l/h	gph					
12017 PVT	12	174	20	5	88	3.9	7	1	3/4" - 10
12017 SST	12	174	20	5	88	3.9	7	1	3/4" - 10
12035 PVT	12	174	42	11	172	4.1	7	1	3/4" - 10
12035 SST	12	174	42	11	172	4.1	7	1	3/4" - 10
10050 PVT	10	145	49	13	200	4.1	7	1	3/4" - 10
10050 SST	10	145	49	13	200	4.1	7	1	3/4" - 10
10022 PVT	10	145	26	7	88	5.1	6	1	3/4" - 10
10022 SST	10	145	26	7	88	5.1	6	1	3/4" - 10
10044 PVT	10	145	53	14	172	5.1	6	1	3/4" - 10
10044 SST	10	145	53	14	172	5.1	6	1	3/4" - 10
07065 PVT	7	102	63	17	200	5.3	6	1	3/4" - 10
07065 SST	7	102	63	17	200	5.3	6	1	3/4" - 10
07042 PVT	7	102	50	13	88	9.6	3	1	1" - 15
07042 SST	7	102	50	13	88	9.6	3	1	1" - 15
04084 PVT	4	58	101	27	172	9.8	3	1	1" - 15
04084 SST	4	58	101	27	172	9.8	3	1	1" - 15
04120 PVT	4	58	117	31	200	9.8	3	1	1" - 15
04120 SST	4	58	117	31	200	9.8	3	1	1" - 15

All figures refer to water at 20 °C.

The suction lift applies to filled suction line and filled liquid end - when installed correctly.

#### Accuracies

Data	Value	Unit
Reproducibility	±2	% *

\* - when installed correctly, under constant conditions, at least 30 % stroke length and water at 20 °C



## 14.2 Viscosity

The liquid ends are suitable for the following viscosity ranges:

Version	Stroke rate, max.	Viscosity
	Strokes/min	mPas
Standard	180	0 ... 200
With valve springs	130	200 ... 500
With valve springs and suction-side feed	90	500 ... 1000*

\* Only when the installation is correctly adjusted

## 14.3 Shipping weight

Types	Material version	Shipping weight
		kg
12017; 12035; 10050	PVT	9.8
	SST	11.7
10022; 10044; 07065	PVT	9.8
	SST	11.7
07042; 04084; 04120	PVT	10.0
	SST	13.2

## 14.4 Wetted materials

Material version	Liquid end	Suction/discharge connector	Seals* / ball seat	Balls	Springs	Integral relief valve
PVT	PVDF	PVDF	PTFE/PTFE	Ceramic	Hastelloy C	PVDF / FPM or EPDM
SST	Stainless steel 1.4404	Stainless steel 1.4581	PTFE/PTFE	Stainless steel 1.4404	Hastelloy C	Stainless steel / FPM or EPDM

\* Metering diaphragm is PTFE coated

## 14.5 Ambient conditions

### 14.5.1 Ambient temperatures

Pump, compl.

Data	Value	Unit
Storage and transport temperature	-10 ... +50	°C
Ambient temperature in operation (drive + motor):	-10 ... +45	°C

## 14.5.2 Media temperatures

PVT liquid end

Data	Value	Unit
Max. temperature long-term at max. operating pressure	65	°C
Max. temperature for 15 min at max. 2 bar	100	°C
Minimum temperature	-10	°C

SST liquid end

Data	Value	Unit
Max. temperature long-term at max. operating pressure	90	°C
Max. temperature for 15 min at max. 2 bar	120	°C
Minimum temperature	-10	°C

## 14.5.3 Air humidity

Air humidity

Data	Value	Unit
Maximum air humidity *:	95	% rel. humidity

\* non-condensing

## 14.5.4 Enclosure rating and safety requirements

Degree of protection

Protection against contact and humidity:

IP 65 in accordance with IEC 529, EN 60529, DIN VDE 0470 Part 1



*A CAN plug or the supplied sealing cap must always be plugged into the CAN port for the HMI.*

Safety requirements

Degree of protection:

1 - mains power connection with protective earth conductor

## 14.6 Electrical connection



*The electrical data do not relate to the motor, but the pump, which is connected as a whole unit.*

*For the motor electrical data use the motor data sheet in the appendix.*

Electrical data S1Cb pump

Identity code specification "power supply" - "U": 100 - 230 V ± 10 %, 240 V ± 6 %, 50/60 Hz

**Electrical data at 100 V**

Data	Value	Unit
Switch on peak current, (for approx. 100 ms)	4	A

**Electrical data at 230 V**

Data	Value	Unit
Switch on peak current, (for approx. 100 ms)	8	A

**Fuses**

Fuse	Value	Part no.
Fuse, internal	3.15 AT - (1.5 kA)	732414

 *Only use the original fuses from ProMinent! It is not sufficient to use a fuse with the above fuse rating.*

## 14.7 Diaphragm rupture sensor

**Contact (standard)**

**Contact loading, max.**

at voltage	Maximum current
30 V DC	1 A

The contact is an opener.

The contact is an potential-free.

 – *For safety reasons we recommend connecting to a protective low voltage, e.g. in accordance with EN 60335-1 (SELV).*  
 – *The cable can be poled as required.*

## 14.8 Relay

 *The technical data for the relay are contained in the chapter "Installation, electrical".*

## 14.9 Sound pressure level

**Sound pressure level**

Sound pressure level LpA < 70 dB in accordance with EN ISO 20361:2010-10

at maximum stroke length, maximum stroke rate, maximum back pressure (water)

# 15 Motor data sheets

ProMinent®

<b>Motor Datenblatt / Motor data sheet / Fiche technique pour moteur / Hoja de datos del motor</b>			
<b>Bestell Nr. / order no.</b> no. de commade / No.de pedido		<b>1042145</b>	<b>Hersteller / producer</b> producteur / fabricánte
			<b>Bonfiglioli</b> (W83032050790023)
<b>Motor- Typ</b> motor type type du moteur tipo de motor	X_BN 56B 4 230/400-50 IP55 CLF B5 12649/1000	<b>Leistungsfaktor</b> power factor facteur de puissance factor de potencia	0,6
<b>Maschinenart</b> type of machine désignation tipo de máquina	3 Ph. Motor	<b>Wirkungsgrad</b> efficiency rendement rendimiento	51,7 % (100 %) 47,6 % (75 %)
<b>Schutzart</b> degree of protection degré de protection clase de protección	IP 55	<b>Bemessungsfrequenz</b> rated frequency fréquence nominale frecuencia nominal	50 / 60 Hz
<b>Bauform</b> mounting construction Forma constructiva	B5	<b>Bemessungsdrehzahl</b> rated speed vitesse nominale velocidad nominal	1350/1620 U/min rpm t/mn
<b>Bemessungsleistung</b> rated output puissance nominale potencia nominal	0,09 kW	<b>Wärmeklasse</b> temperature class class d'isolement clase térmica	F
<b>Bemessungsspannung</b> rated voltage tension nominale tension nominal	△ / Δ 400/230 V (+/- 10%)	<b>Anzugsstrom</b> starting current courant de démarrage corrente de arranque	2,6 fach fold fois veces
<b>Bemessungsstrom</b> rated current courant nominale corriente nominal	0,42 A bei / at 400 V	<b>Anzugsmoment</b> starting torque couple de démarrage par de arranque	2,4 fach fold fois veces
<b>Geprüft nach</b> tested in acc. with contrôlé selon testado de acuerdo a	CEI EN 60034-1	<b>Kippmoment</b> pull-out torque couple de décrochage par de inversión	2,5 fach fold fois veces
<b>ATEX Nr.</b>		<b>Umgebungstemperatur</b> ambient temperature température ambiante temperatura ambiente	-15° C - +40° C
<b>Ex-Schutzklasse</b> ex-protective system class de protection Ex clase de protección Ex		<b>Schaltung</b> connection branchement conexión	△ / Δ
		<b>Drehzahlregelbereich</b> speed ajustment range	
<b>Anmerkung</b> comments observation observación	Getriebemotor / drive motor / motoréducteur / motorreductor Übersetzung / drive ratio / rapport de transmission / relación de transmisión: 20:1		
<b>ProMinent</b> Pumpentyp pump type type de pompe tipo de bomba	S1CbH _____ U _____		
Die Daten entsprechen den Angaben der Motorenhersteller. Kenndaten funktionsgleicher Motoren anderer Hersteller ändern sich nur unwesentlich. Angaben ohne Gewähr. The data correspond to the details given by the motor manufacturers. Ratings of motors with the same functions made by other producers show insignificant changes only. This information is supplied without liability. Les données techniques correspondent au descriptif du fabricant des moteurs. Les données techniques des moteurs similaires chez d' autres fabricants varient très peu. Données sont d' ordre général.Los datos corresponden la información obtenida por el fabricante de Motores. Las características del funcionamiento identico de los Motores de otros fabricantes cambian solo marginalmente. A la Información no se asuma responsabilidad.			

# 16 Dimension sheets

## Sigma/ 1 Control Type S1Cb

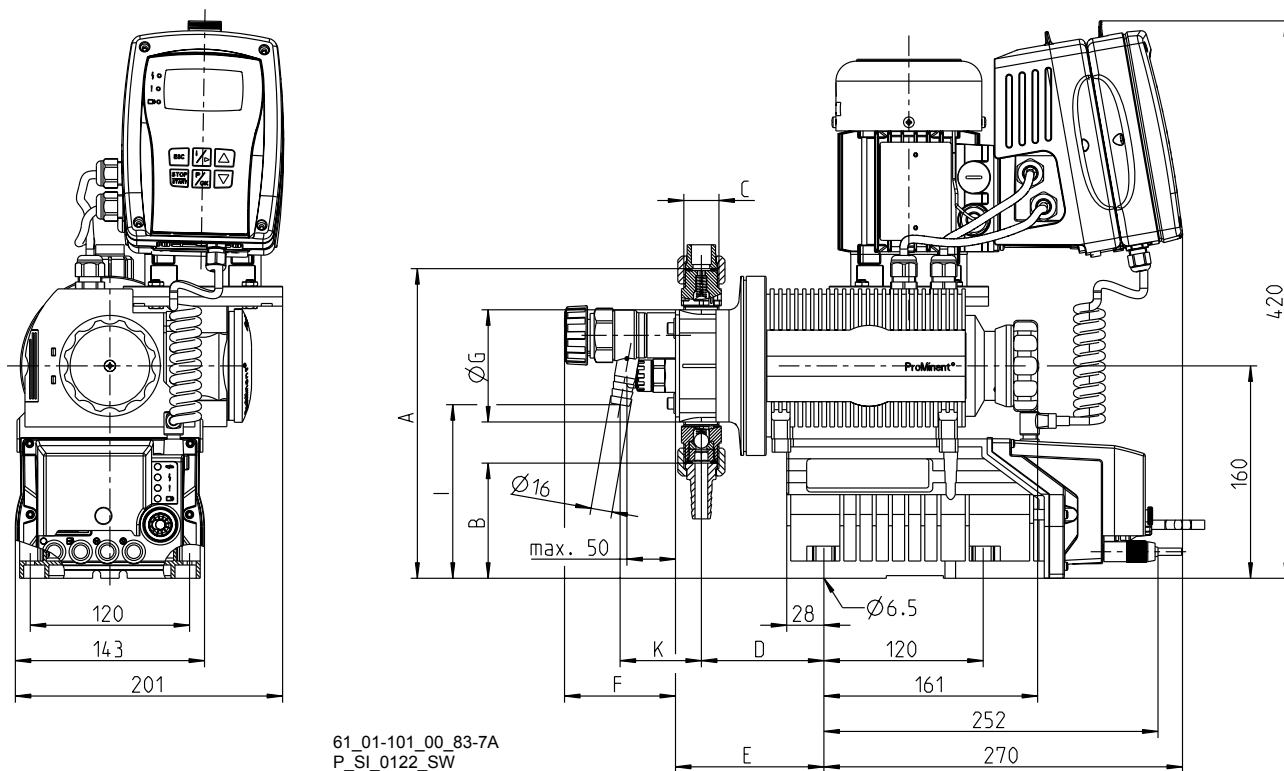

Fig. 36: Dimensions in mm

Type	Conne- ction	A	B	C	D	E	F*	ØG	I*	K*
12017, 12035, 10050 PVT	DN 10	234	87	G1 3/4 A	93	112*/ 109	84	96	131	62
12017, 12035, 10050 SST	DN 10	231	89	G1 3/4 A	92	108	88	108	100	45
10022, 10044, 07065 PVT	DN 10	234	87	G1 3/4 A	93	112*/ 109	84	96	131	62
10022, 10044, 07065 SST	DN 10	231	89	G1 3/4 A	92	108	88	108	100	45

## Dimension sheets

Type	Conne- tion	A	B	C	D	E	F*	ØG	I*	K*
07042, 04084, 04120 SST	DN 15	243	78	G1 A	98	129*/ 119	74	122	138	63
07042, 04084, 04120 PVT	DN 15	243	78	G1 A	97	118	88	124	112	51

### Tube nozzle relief valve with thread

Thread	ØS
G 3/4 A	16

### HMI and wall bracket

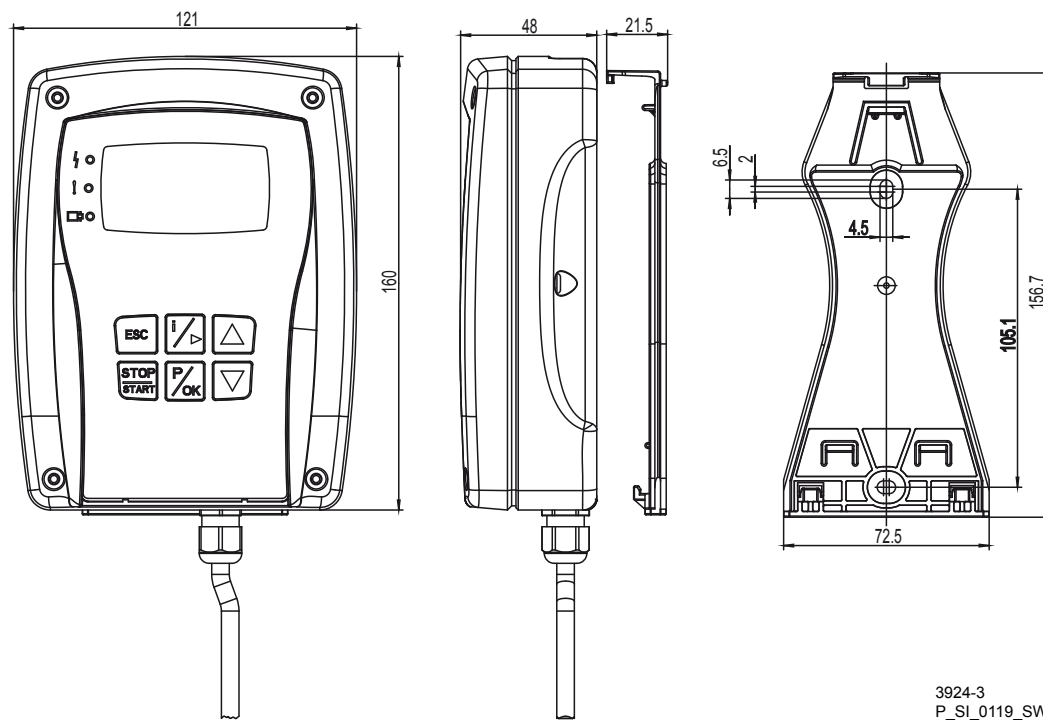
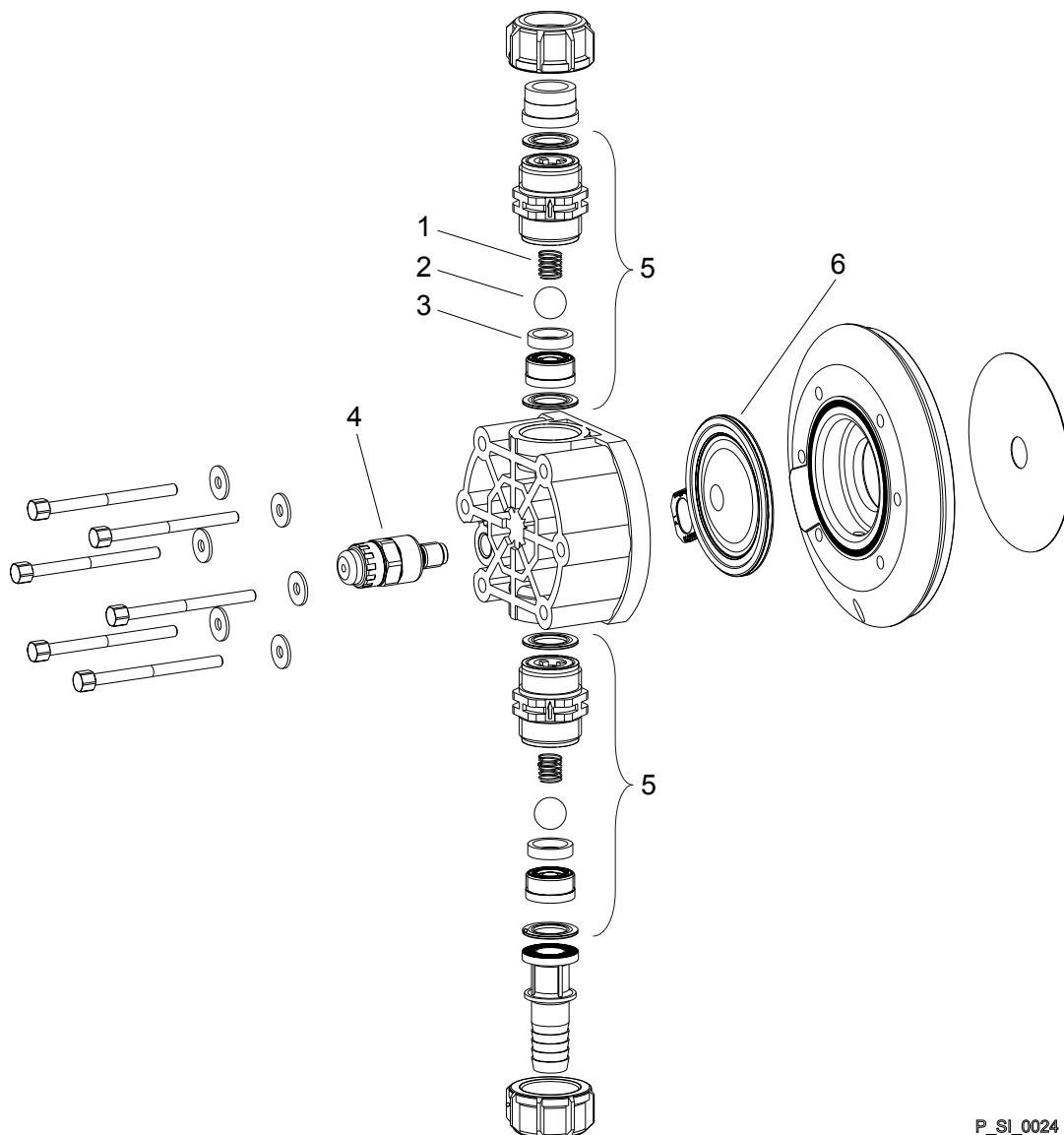

Fig. 37: Dimensions in mm

## 17 Exploded view drawings

### 17.1 Exploded drawings Sigma/ 1

Liquid end Sigma/ 1 050 and 065 PVT



P\_SI\_0024

Fig. 38: Liquid end Sigma/ 1 050 and 065 PVT

Item	Description	Type 12035, 12017, 10050	Type 07065, 10044, 10022
1	Spring	**	**
2	Ball	*	*
3	Ball seat	*	*
4	Diaphragm rupture sensor, visual	1033323	1033323
5	Valve	1002267*	1002267*
6	Multi-layer diaphragm	1030114*	1030115*

\* The items listed are included in the spare parts kit. \*\* Special accessories (not included in the spare parts kit). Technical changes reserved.

Liquid end Sigma/ 1 120 PVT

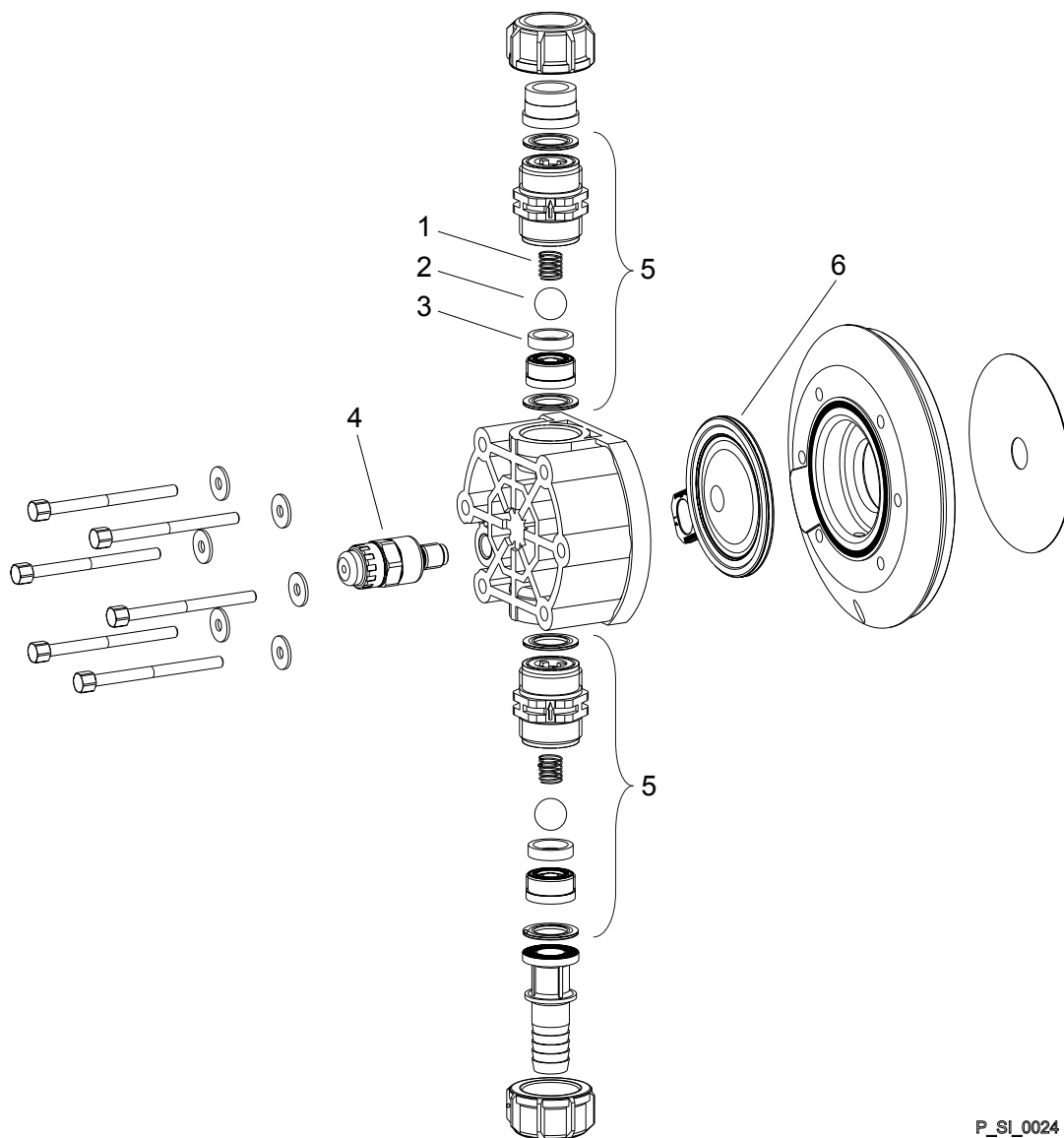

P\_SI\_0024

Fig. 39: Liquid end Sigma/ 1 120 PVT

Item	Description	Type 04084, 04120, 07042
1	Spring	**
2	Ball	*
3	Ball seat	*
4	Diaphragm rupture sensor, visual	1033323
5	Valve	792517*
6	Multi-layer diaphragm	1035828*

\* The items listed are included in the spare parts kit. \*\* Special accessories (not included in the spare parts kit). Technical changes reserved.



Sigma/ 1 PVT bleed valve

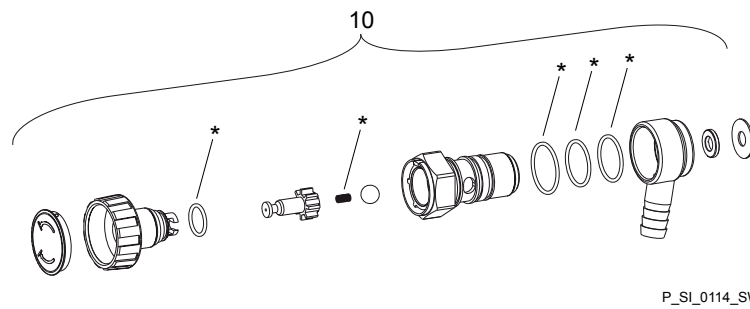
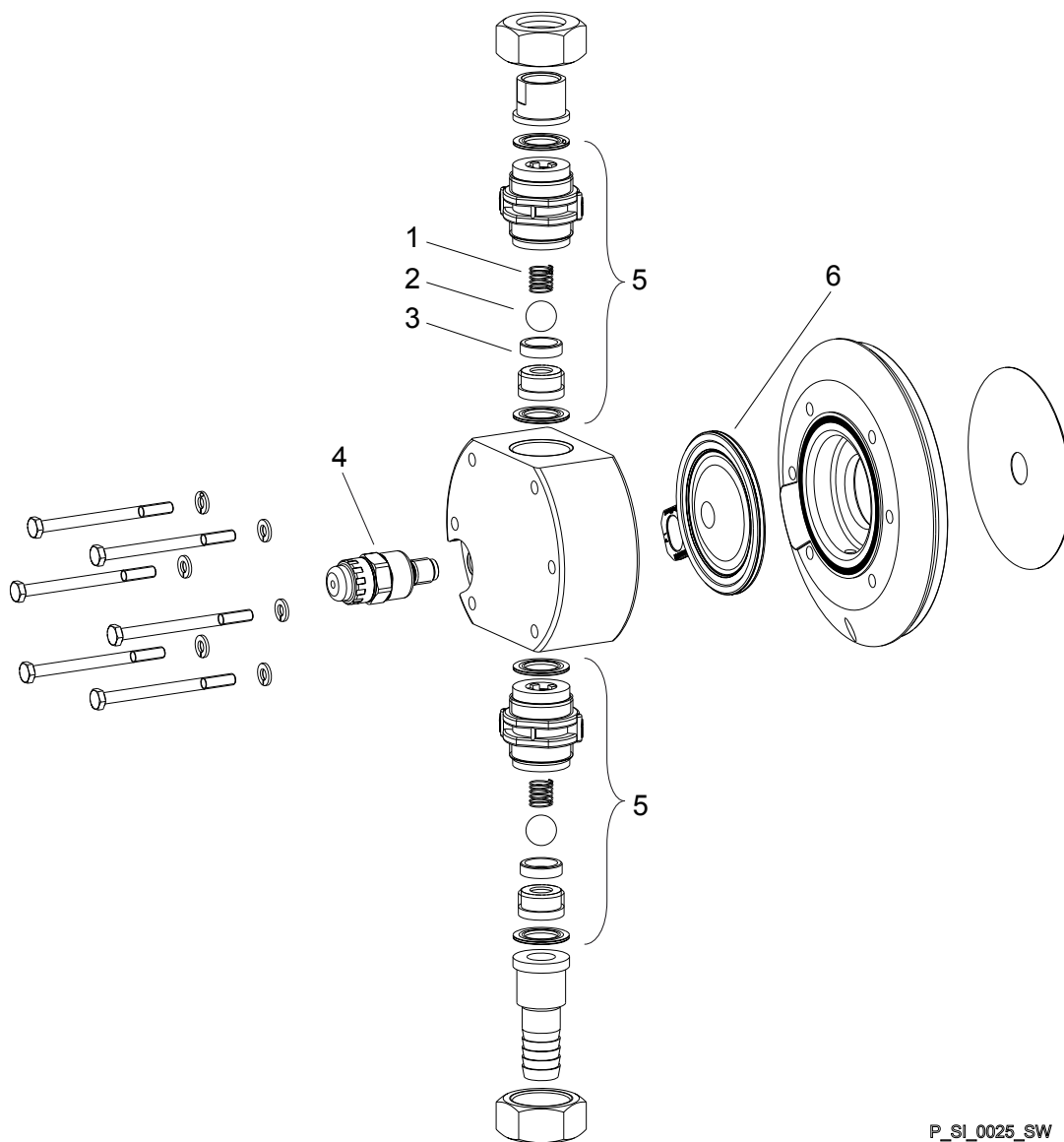

Fig. 40: Sigma/ 1 PVT bleed valve

Item	Description	Part no.
10	Integrated bleed valve, complete, DN10 PVA	1041067
10	Integrated bleed valve, complete, DN10 PVE	1041068

\* The items listed are included in the spare parts kit. Springs made from Hastelloy C, O-rings from FPM-A and EPDM. Technical changes reserved.

Liquid end Sigma/ 1 050 and 065 SST



P\_SI\_0025\_SW

Fig. 41: Liquid end Sigma/ 1 050 and 065 SST

Item	Description	Type 12035, 12017, 10050	Type 07065, 10044, 10022
1	Spring	**	**
2	Ball	*	*
3	Ball seat	*	*
4	Diaphragm rupture sensor, visual	1033323	1033323
5	Valve	809459	809459
6	Multi-layer diaphragm	1030114*	1030115*

\* The items listed are included in the spare parts kit. \*\* Special accessories (not included in the spare parts kit). Technical changes reserved.

Liquid end Sigma/ 1 120 SST

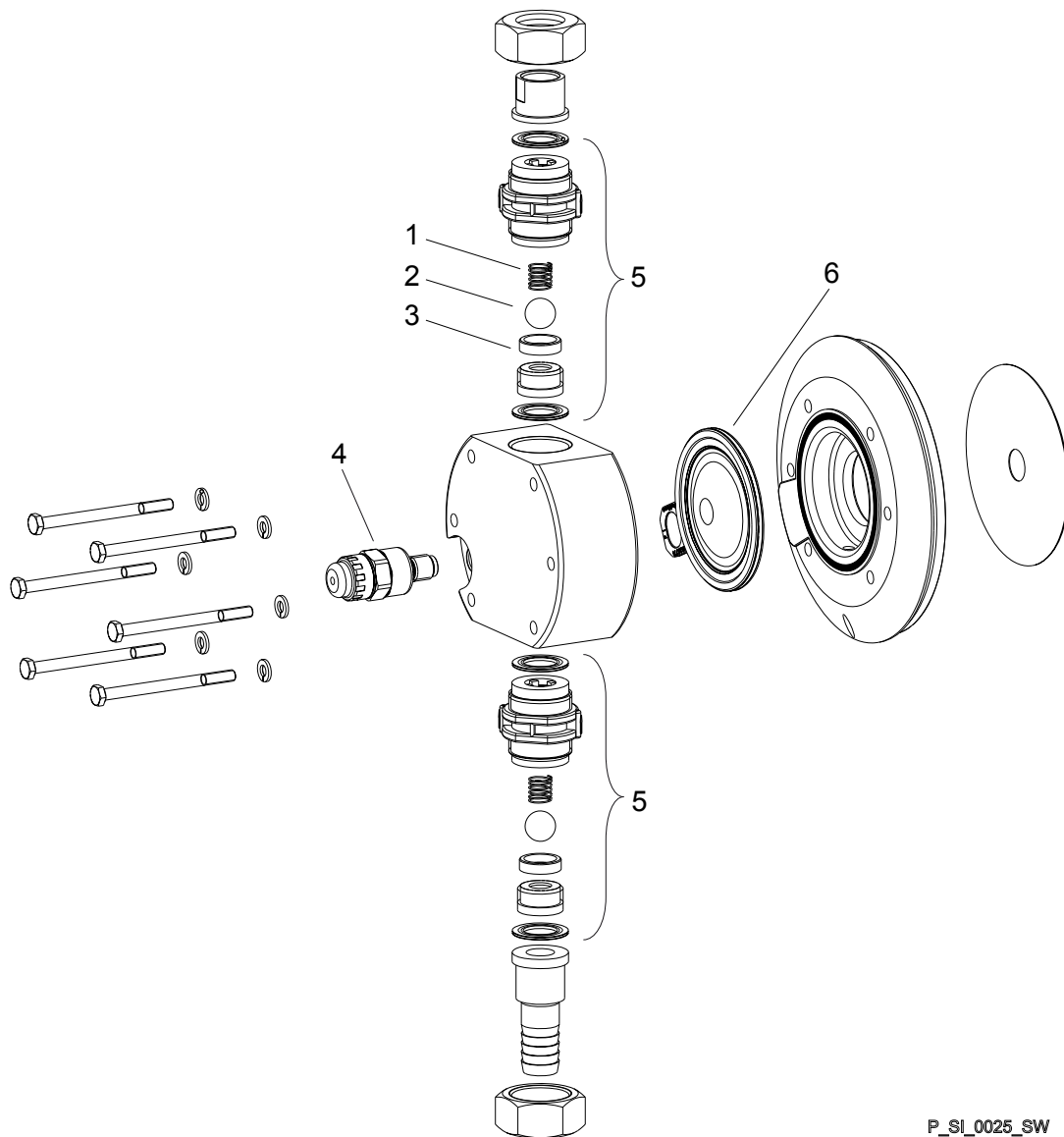

P\_SI\_0025\_SW

Fig. 42: Liquid end Sigma/ 1 120 SST

Item	Description	Type 04084, 04120, 07042
1	Spring	**
2	Ball	*
3	Ball seat	*
4	Diaphragm rupture sensor, visual	1033323
5	Valve	809404
6	Multi-layer diaphragm	1035828*

\* The items listed are included in the spare parts kit. \*\* Special accessories (not included in the spare parts kit). Technical changes reserved.

Sigma/ 1 SST bleed valve

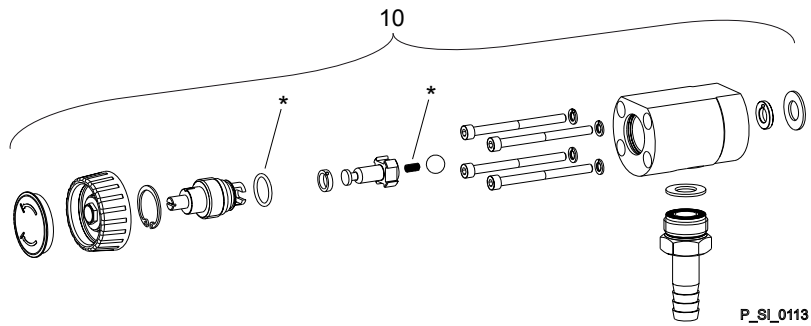

Fig. 43: Sigma/ 1 SST bleed valve

Item	Description	Part no.
10	Integrated bleed valve, complete, DN10 SSA	1041071
10	Integrated bleed valve, complete, DN10 SSE	1041072

\* The items listed are included in the spare parts kit. Springs made from Hastelloy C, O-rings from FPM-A and EPDM. Technical changes reserved.

## 18 Ordering Information

Spare parts kits normally include the wearing parts of a liquid end.



*Other locations where ordering information can be found: Exploded assembly drawings, general operating instructions for ProMinent® motor-driven metering pumps and hydraulic accessories, ProMinent® product catalogue, [www.prominent.com](http://www.prominent.com).*

### Spare parts kits PVT (liquid ends)

Spare parts kit	Types 12017, 12035, 10050	Types 10022, 10044, 07065	Types 07042, 04084, 04120
FM 50 - DN 10	1035964		
FM 65 - DN 10		1035967	
FM 120 - DN 15			1035961

Scope of supply: see exploded view drawings.

### Spare parts kits SST (liquid ends)

Spare parts kit	Types 12017, 12035, 10050	Types 10022, 10044, 07065	Types 07042, 04084, 04120
FM 50 - DN 10	1035966		
FM 50 with 2 complete valves	1035965		
FM 65 - DN 10		1035969	
FM 65 with 2 complete valves		1035968	
FM 120 - DN 15			1035963
FM 120 with 2 complete valves			1035962

Scope of supply: see exploded view drawings.

### Spare parts kits for integrated bleed valve

Spare parts kit	for material version	Seals	Part no.
ETS EV	PVT/SST	FPM-A and EPDM	1043785

Scope of supply: see exploded view drawings.

### HMI spare parts

Spare part	Part no.
HMI wall bracket	1036683
HMI protective film	1036724

# 19 Diagrams for adjusting the capacity

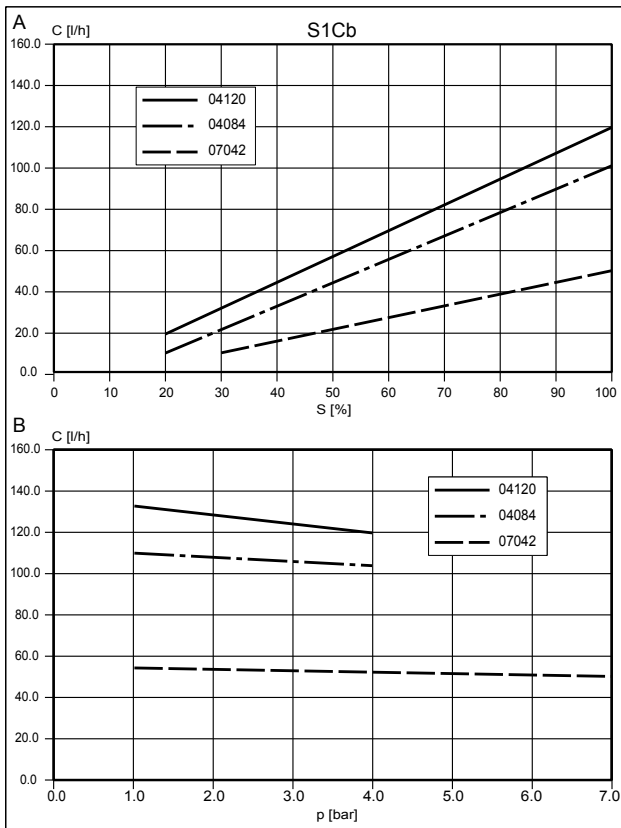
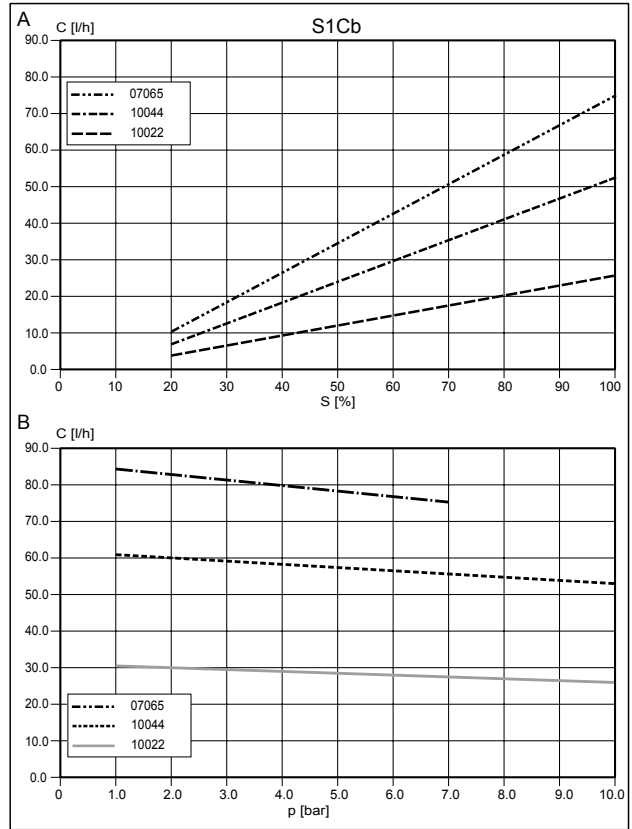
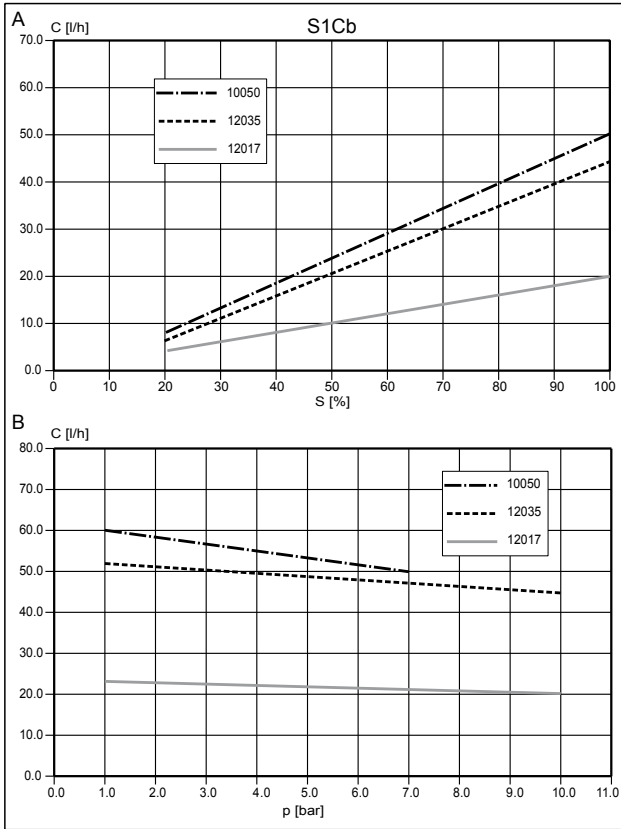

Fig. 44: A) Capacity C at minimum back pressure dependent on the stroke length s. B) Capacity C dependent on the back pressure p.

## 20 EC Declaration of Conformity

### - Original - EC Declaration of Conformity for Machinery

We, **ProMinent Dosiertechnik GmbH**  
**Im Schuhmachergewann 5 - 11**  
**D - 69123 Heidelberg**

hereby declare that the product identified below conforms to the basic health and safety requirements of the EC Directive, by virtue of its design and construction, and in the configuration placed on the market by us.  
This declaration is no longer applicable if changes are made to the product without our authorisation.

Product description: ***Dosing pump, Sigma series***

Product type: ***S1Cb***

Serial no.: ***see type plate on the unit***

Applicable EC Directives: ***EC Machinery Directive (2006/42/EC)***  
***EC EMC Directive (2004/108/EC)***  
***The safety objectives of the Low Voltage Directive 2006/95/EC were complied with in accordance with Appendix 1, No. 1.5.1 of the Machinery Directive 2006/42/EC***

Applied harmonised standards, especially: ***EN ISO 12100, EN 809,***  
***EN 60335-1, EN 60335-2-41***  
***EN 61000-6-2, EN 61000-6-4***

Technical documentation was compiled by the authorised representative for documentation: ***Dr. Johannes Hartfiel***  
***Im Schuhmachergewann 5-11***  
***D - 69123 Heidelberg***

Date / Manufacturer signature: ***13.11.2012***

Name / position of the signatory: ***Joachim Schall, Manager Innovation and Technology***

## 21 Operating / adjustment overview

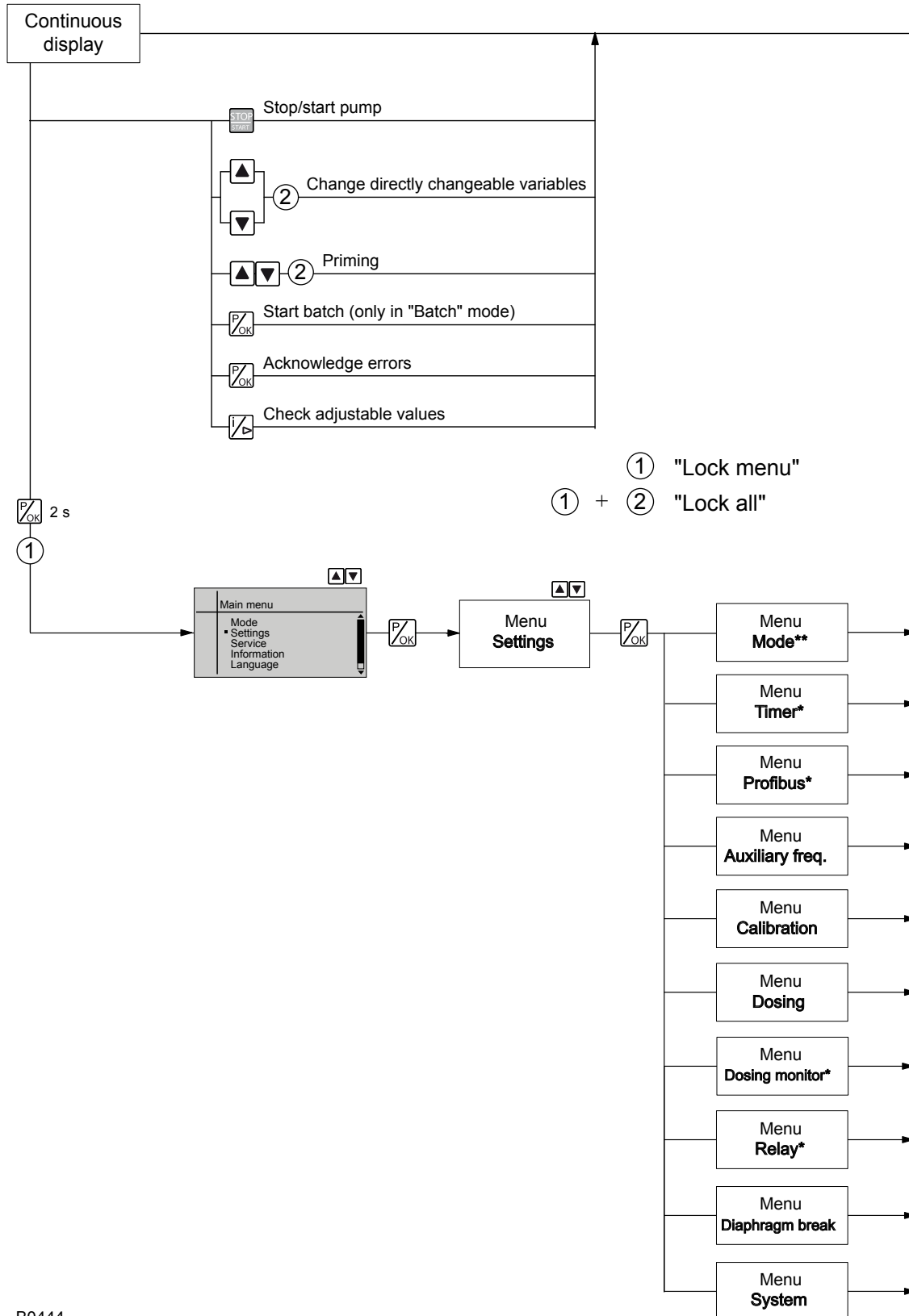

B0444

Fig. 45: \* Menu appears only with corresponding module



## 22 Continuous displays

### Continuous displays

Continuous display	Mode "Manual"	Mode "Batch" with memory and transfer factor 5	Mode "Contact" with memory	Mode "Analog"
Stroke rate (Strokes/min)				
Factor				
Remaining litres				
Capacity				
		Identifier "m" only if function extension "Stroke memory" activated.		

= variables directly changeable using the [Up] and [Down] arrow keys

### Auxiliary displays in the continuous display

Auxiliary display	Mode "Manual"	Mode "Batch" with memory and transfer factor 5	Mode "Contact" with memory and transfer factor 5	Mode "Analog"
Total number of strokes	86500 Cp	86500 Cp	86500 Cp	86500 Cp
Stroke length	65 %	65 %	65 %	65 %
Total litres (metering quantity)	576,67 L <sup>1</sup>	576,67 L <sup>1</sup>	576,67 L <sup>1</sup>	576,67 L <sup>1</sup>
Remaining strokes		25,00 ↓ Cp <sup>2</sup>	25,00 ↓ Cp <sup>2</sup>	
Factor		5 Cp / $\frac{1}{s}$	5 Cp / $\frac{1}{s}$	
Signal current (at the input)				12,7 mA <sup>3</sup>
Stroke rate (Strokes/min)	180 Cp/min	180 Cp/min	180 Cp/min	180 Cp/min
Dosing mode	Standard	Standard	Standard	Standard
Capacity	80,00 L/h <sup>1</sup>	80,00 L/h <sup>1</sup>	80,00 L/h <sup>1</sup>	80,00 L/h <sup>1</sup>
Batch size/remaining litres		0,833 ↓ L <sup>1,2</sup>	0,833 ↓ L <sup>1,2</sup>	
Stroke rate (Strokes/h)	12000 Cp/h	12000 Cp/h	12000 Cp/h	12000 Cp/h

1 = only by running through the CALIBRATE menu, even after changing the operating mode

2 = only with function extension "Memory"

3 = only with current output

## 23 Index

"	
"External control" terminal.....	39
<b>1, 2, 3 ...</b>	
4 - 20 mA.....	51
<b>A</b>	
Access protect.....	62
Accuracy.....	80
Adjustment, chapter.....	44
Adjustment mode.....	45
Air humidity.....	82
Ambient conditions.....	81
Analog.....	24, 26, 51
Analog current output.....	25
Analog error.....	53
Analog output.....	59
Assembly.....	28
AUX.....	54
Auxiliary frequency.....	24, 26, 39, 54, 57
<b>B</b>	
Basic principles of control adjustment.....	44
Batch.....	24, 26, 47
Bleeder valve.....	33
BUS.....	24
<b>C</b>	
Calibrate.....	24, 55
CAN bus.....	15, 41
CANopen status indicator.....	26
Capacity.....	80, 94
Cavitation.....	56
Checking adjustable values.....	44
Cleaning valves.....	69
CLEAR COUNTERS.....	60
Climate.....	82
Connector size.....	80
Contact.....	24, 26, 48, 83
Continuous displays.....	44
Contrast.....	61
Control.....	57
Control elements.....	15
Correct and proper use.....	9
Current output.....	37
<b>D</b>	
Decommissioning.....	78
Decontamination declaration.....	13
Degree of protection.....	82
Diagrams.....	94
Diaphragm.....	21
Diaphragm break.....	59
Diaphragm rupture sensor.....	15, 83
Dimension sheet HMI + wall bracket.....	86
Dimension sheet pump.....	85
Discharge opti.....	56
Discharge valve.....	21
DISPLAY.....	61
Disposal.....	79
Dosing.....	56, 57
Dosing head.....	21
Dosing monitor.....	57
Dosing profile.....	56
Drive motor.....	15
Drive unit.....	15, 20
<b>E</b>	
Electrical data.....	82
Emergency.....	11
Emptying the liquid end.....	79
Error.....	26, 57
Error messages.....	44
Extended.....	51, 53
External analog.....	26
External contact.....	26, 39
External frequency changeover.....	26
<b>F</b>	
Factor.....	47, 48
Fault indicating relay.....	25, 36, 37
Fault indicator.....	15, 26
Fault processing.....	53
Fault statuses.....	26
Flow.....	25, 57
Functional description.....	20
Function indicator.....	26
Functions.....	24, 26
Function settings.....	54
<b>G</b>	
Gallon.....	60
Gaseous feed chemicals.....	56
<b>H</b>	
Hardware versions.....	63
Hierarchy of operating modes.....	26
HMI.....	29, 41
HMI login.....	61
HMI logout.....	61
HMI operating unit.....	41
<b>I</b>	
Identification of safety notes.....	9
Identity code.....	63
Information.....	63
Information in the event of an emergency.....	11
Installation.....	31
Integral bleeder valve.....	33
IP.....	82

<b>K</b>		
Keys.....	15, 17	
<b>L</b>		
Language.....	63	
Leakage hole.....	68	
LED.....	15	
Level switch.....	25	
Linear.....	52	
Liquid end.....	15, 21	
Liter.....	60	
<b>M</b>		
Maintenance.....	67	
Manual.....	24, 26, 47	
Manual operation.....	64	
mA-Output.....	15, 25	
Materials.....	81	
Memory.....	47, 48	
Mixing, optimal.....	56	
Mode.....	46	
<b>N</b>		
NPSH.....	56	
<b>O</b>		
Operating indicator.....	15, 26	
Operating modes.....	24, 26	
Operating mode selection.....	46	
Operating mode settings.....	46	
Operation.....	64	
Optional module.....	15	
Options.....	25	
Ordering Information.....	93	
Output relay.....	25, 35, 37	
Overload switch-off.....	24	
Overview of equipment.....	15	
<b>P</b>		
Pacing relay.....	25	
Password.....	62	
Pause.....	25, 26, 39	
Power supply.....	42	
Priming.....	25, 26	
PROFIBUS®.....	15	
Protection against contact and humidity.....	82	
Protection class.....	82	
Pump capacity.....	80	
<b>Q</b>		
Qualification of personnel.....	11	
<b>R</b>		
Radioactive.....	13	
Relay.....	57	
Relay behaviour.....	57	
Relay output.....	15	
Relief valve.....	15	
Remote operation.....	66	
Repairs.....	69	
Replacing the Diaphragm.....	71	
Replacing the metering diaphragm.....	71	
Reproducibility.....	80	
<b>S</b>		
Safety chapter.....	9	
Safety requirements.....	82	
Scope of supply.....	13	
Secondary displays.....	45	
Security.....	62	
Semiconductor relay.....	25, 36, 37	
Serial number.....	63	
SERVICE.....	60	
Shipping weight.....	81	
Sideband.....	53	
Signalization.....	57	
Sockets.....	15	
Software versions.....	63	
Sound pressure level.....	12, 83	
Spare Parts kits.....	93	
Standard.....	51	
Status LED CAN bus, internal.....	15	
Stop.....	25, 26	
Storage.....	13	
Storage and transport temperature.....	81	
Stroke length.....	63	
Stroke length adjustment wheel.....	15	
Suction lift.....	80	
Suction opti.....	56	
Suction valve.....	21	
System.....	60	
<b>T</b>		
Temperatures.....	81	
Timer.....	15	
Tolerance.....	57	
Total litres.....	60	
Total number of strokes.....	60	
Transport.....	13	
<b>U</b>		
Unit.....	60	
Unpacking.....	13	
<b>V</b>		
Versions.....	63	
Viscosity.....	56, 81	
<b>W</b>		
Wall bracket.....	86	
Warning.....	57	
Warning indicator.....	15, 26	
Warning sign.....	9	
Weight.....	81	
Wetted materials.....	81	