

DP, EF, SL1, SLV and AUTO_{ADAPT} pumps

0.6 to 2.6 kW
50 Hz



Contents

Introduction

Introduction	3
Applications	3
Construction features	4

Identification

Type keys	5
Nameplates	9

Selection of product

Ordering a pump	10
-----------------	----

Performance range

Performance overview	11
----------------------	----

Product range

Standard pumps	12
Explosion-proof pumps	16

Variants

List of variants	20
------------------	----

Construction

Material specification, DP and EF pumps	22
Material specification, DP10 and EF AUTO _{ADAPT} pumps	29
Material specification, SL1 and SLV pumps	37
Material specification, SL1 and SLV AUTO _{ADAPT} pumps	42

Product description

Features	48
Operating conditions	49
Pumped liquids	49
Motor range	49
Frequency converter operation	49
Approvals	50
Wiring diagrams	51

Curve charts

Curve conditions	53
Performance tests	53
Certificates	53
Witness test	53
DP10.50	54
DP10.65	57
EF30.50	58
SL1.50.65	65
SLV.65.65	70

Dimensions

DP and EF standard and AUTO _{ADAPT} pumps	78
SL1 and SLV standard and AUTO _{ADAPT} pumps	88

Accessories

Installation systems	92
Other accessories	92
DP, EF, SL1 and SLV pumps	93
DP, EF, SL1 and SLV AUTO _{ADAPT} pumps	96

Further product documentation

WebCAPS	98
WinCAPS	99

Introduction

This data booklet deals with small Grundfos DP, EF, SL1 and SLV wastewater pumps, both standard pumps and AUTO_{ADAPT} pumps.



Fig. 1 DP, EF, SL1 and SLV pumps

The pumps are SuperVortex (free-flow) and single-channel impeller pumps specifically designed for pumping sewage and wastewater in a wide range of municipal, private and industrial applications.

The pumps are made of wear-resistant materials, such as cast iron and stainless steel. These materials ensure reliable operation.

The pumps are available with motors of 0.6 kW and up to and including 2.6 kW.

The nominal diameter of the pump discharge port is 10 to 65 mm.

The pumps are available for

- submerged installation on auto-coupling system
- submerged installation, free-standing.

Applications

Typical applications are transfer of liquids, such as:

- municipal wastewater
- wastewater with high content of fibres (SuperVortex impeller)
- drainage water and groundwater
- domestic wastewater
- industrial wastewater
- process and cooling water.

The pumps are ideal for the pumping of the above liquids from for instance:

- municipal network pumping stations
- public buildings
- blocks of flats
- factories/industry.

Construction features

All pumps have the following features:

- Watertight cable entry of corrosion-resistant polyamide.
- Power supply cable incorporating wires for thermal sensors in the motor windings.
- No additional cable required for sensors in pumps with sensors.
- Monitoring of operating conditions for pumps with sensors.
- Moisture detector for continuous monitoring of motor enclosure and automatic cut-out in case of leakage.
- Heavy-duty bearings greased for life.
- Built for frequency converter operation.
- Smooth pump surface prevents dirt and impurities from sticking to the pump.
- Self-cleaning channel impeller with long vanes reducing the risk of jamming or clogging, or Super-Vortex impeller with high pumping efficiency and less downtime.
- Explosion-proof motors for potentially explosive environments.
- Motor insulation class F (155 °C).
- Enclosure class IP68 with thermal sensor in each phase.

Service-friendly design:

- Clamp connection between motor and pump.
- Cartridge shaft seal.
- Cable connection to motor via plug.

Additional DP, EF, SL1 and SLV AUTO_{ADAPT} features

The pumps incorporate a controller, sensors and motor protection. They only need to be connected to the mains supply.

The pumps offer the following benefits:

- Built-in level and dry-running sensors.
- Built-in motor protection.
- Pump alternation.
If several pumps are installed in the same tank, the control logic incorporated in the pump will ensure that the load is distributed evenly among the pumps over time.
- Alarm relay output.
The pump incorporates an alarm relay output. NC and NO are available and can be used as required, for example for acoustic or visual alarms.

Alarm	Alarm log	Signal relay
Overvoltage	•	•
Undervoltage	•	•
Overload	•	•
Blocked motor/pump	•	•
Dry running	•	
Motor temperature	•	•
Electronics temperature (Pt1000)	•	•
Thermal switch 1 in motor	•	•
Thermal switch 2 in motor	•	•
Phase sequence reversed	•	•
High-level alarm		•
Sensor fault	•	•

- Random start delay in case of general power shutdown.
- The pump does not start unless the phase sequence is correct.
- Self-calibration after each pump cycle.
- Anti-seizing function.
The anti-seizing function starts the pump at programmed intervals to prevent the impeller from seizing up. This function will overrule the dry-running sensor of non-Ex versions.
- After-run function (foam draining).
The after-run function can be used at programmed intervals if there is a risk of a floating layer.

The Grundfos CIU unit can be permanently or temporarily connected for changing the default settings, making further settings or reading the alarm log and operating parameters, such as number of starts and operating hours.

Type keys

DP and EF

Code	Example	DP	1	10	.65	.11	.A	.Ex	.2	.5	02
	Pump range										
DP	Grundfos drainage pump										
EF	Grundfos effluent pump										
	Material										
Blank	Standard, cast iron										
	Impeller type										
1	Single-channel impeller										
V	SuperVortex (free-flow) impeller										
	Pump passage										
10	Maximum solids size [mm]										
	Pump discharge										
65	Nominal diameter of discharge port [mm]										
	Output power, P2										
11	P2 = code number from type designation/10 [kW]										
	Sensor version										
Blank	Standard										
A	Connected to a CU 100 control box										
	Pump version										
Blank	Non-explosion-proof pump (standard)										
Ex	Explosion-proof pump										
	Number of poles										
2	2 poles										
	Mains frequency										
5	50 Hz										
	Supply voltage and starting method										
02	230 V, direct-on-line starting										
0B	400-415 V, direct-on-line starting										
0C	230-240 V, direct-on-line starting										
	Materials in pump										
Blank	Standard materials in pump										

DP and EF AUTO_{ADAPT}

Code	Example	DP	10	.50	.15	.E	.Ex	.2	.1	.5	02
DP EF	Type range Grundfos drainage pump Grundfos effluent pump										
Blank	Material Standard, cast iron										
10	Maximum spherical impeller clearance [mm]										
50	Pump discharge Nominal diameter of discharge port [mm]										
15	Output power, P2 P2 = code number from type designation/10 [kW]										
Blank E	Equipment in pump Standard Electronic version with AUTO _{ADAPT} functions										
Blank Ex	Pump version Non-explosion-proof pump (standard) Explosion-proof pump										
2	Number of poles 2 poles, n = 3000 min ⁻¹ , 50 Hz										
1 Blank	Number of phases Single-phase motor Three-phase motor										
5	Mains frequency 50 Hz										
02 0B	Supply voltage and starting method 230 V, direct-on-line starting 400-415 V, direct-on-line starting										
Blank A B	Generation First generation Second generation Third generation, etc. The pumps belonging to the individual generations differ in design, but are similar in terms of power rating.										
Blank	Materials in pump Standard materials in pump										

SL1 and SLV

Code	Example	SL	1	.80	.80	.40	.A	.Ex	.4	.5	0D
SL	Pump range Grundfos sewage and wastewater pump										
1	Impeller type Single-channel impeller										
V	SuperVortex (free-flow) impeller										
80	Pump passage Maximum solids size [mm]										
80	Pump discharge Nominal diameter of discharge port [mm]										
40	Output power, P2 P2 = code number from type designation/10 [kW]										
Blank	Sensor version Standard										
A	Connected to a CU 100 control box										
Blank	Pump version Non-explosion-proof pump (standard)										
Ex	Explosion-proof pump										
2	Number of poles 2 poles										
1	Number of phases Single-phase motor										
Blank	Three-phase motor										
5	Mains frequency 50 Hz										
02	Supply voltage and starting method 230 V, direct-on-line starting										
0B	400-415 V, direct-on-line starting										
0C	230-240 V, direct-on-line starting										

Note: The pump types are not available in all variants.

SL1 and SLV AUTO_{ADAPT}

Code	Example	SL	1	.50	.65	.11	.E	.Ex	.2	.1	.5	02
SL	Type range Grundfos sewage and wastewater pump											
Blank	Material Standard, cast iron											
1	Impeller type Channel impeller											
V	SuperVortex impeller											
Blank	Semi-open impeller											
50	Maximum spherical impeller clearance [mm]											
65	Pump discharge Nominal diameter of discharge port [mm]											
11	Output power, P2 P2 = code number from type designation/10 [kW]											
Blank	Equipment in pump Standard											
E	Electronic version with AUTO _{ADAPT} functions											
Blank	Pump version Non-explosion-proof pump (standard)											
Ex	Explosion-proof pump											
2	Number of poles 2 poles, n = 3000 min ⁻¹ , 50 Hz											
1	Number of phases Single-phase motor											
Blank	Three-phase motor											
5	Mains frequency 50 Hz											
02	Supply voltage and starting method 230 V, direct-on-line starting											
0B	400-415 V, direct-on-line starting											
Blank	Generation First generation											
A	Second generation											
B	Third generation, etc. The pumps belonging to the individual generations differ in design, but are similar in terms of power rating.											
Blank	Materials in pump Standard materials in pump											

Note: The pump types are not available in all variants.

Nameplates

Pump nameplates

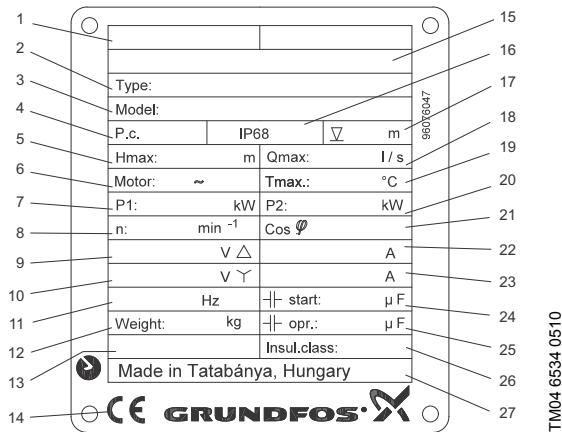

TM04 6534 0510

Fig. 2 DP, EF, SL1 and SLV pumps

Pos.	Description
1	Ex mark
2	Type designation
3	Product number
4	Production code (year/week)
5	Maximum head
6	Number of phases
7	Rated input power
8	Rated speed
9	Rated voltage, Δ
10	Rated voltage, Y
11	Frequency
12	Weight without cable
13	EN approval
14	CE mark
15	Explosion protection
16	Enclosure class to IEC
17	Maximum installation depth
18	Maximum flow rate
19	Maximum liquid temperature
20	Power power
21	Power factor
22	Rated current, Δ
23	Rated current, Y
24	Starting capacitor
25	Operating capacitor
26	Insulation class
27	Country of production

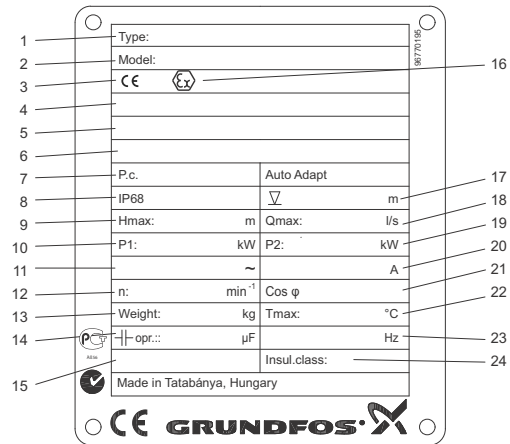

TM04 4459 5209

Fig. 3 DP, EF, SL1 and SLV AUTO_{ADAPT} pumps

Pos.	Description
1	Type designation
2	Product number
3	CE mark
4	ATEX certificate*
5	IEC Ex mark*
6	IEC Ex certificate*
7	Production code (year/week)
8	Enclosure class to IEC
9	Maximum head
10	Rated input power
11	Number of phases
12	Rated speed
13	Weight without cable
14	Operating capacitor
15	EN approval
16	Ex mark*
17	Maximum installation depth
18	Maximum flow rate
19	Output power
20	Rated current
21	Power factor
22	Maximum liquid temperature
23	Frequency
24	Insulation class

* Only explosion-proof pumps.

Ordering a pump

When ordering a pump, you need to take the following aspects into consideration:

- pump type
- custom-built variation (option)
- accessories
- controller
- explosion-proof version.

Pump

Use the table below to identify the pump type that best meets your needs. The table is for guidance only.

Pumped liquid	DP	EF	SL1	SLV
Storm water			•	•
Groundwater	•	•	•	•
Drainage and surface water	•	•	•	•
Drainage and surface water with small impurities	•	•	•	•
Abrasive surface water	•	•	•	•
Wastewater with long fibres, e.g. from laundries		•	•	•
Wastewater from commercial buildings without discharge from toilets		•	•	•
Domestic wastewater with discharge from toilets			•	•
Industrial process water with solids or fibres				•
Industrial process water with solids		•	•	•
Industrial process water without solids and fibres	•	•	•	

When you have selected the pump type, you can identify the specific pump that best meets your needs in sections *Product range*, pages 12 to 19, and *Type keys*, pages 5 to 9.

The list below is a detailed description of the product you get if you order the following pump:

Pump	Product number
SLV.65.65.22.2.51D	96871966

- Pump as specified in the type key.
- 10 metres of cable.
- Paint: NSC 8005-R80B (dark grey), gloss code 35, thickness 100 µ.
- Three thermal switches, one in each phase, or three thermal sensors (PTC).
- Tested according to DIN 9906, Annex A.

See section *Performance curves / Technical data*, pages 54 to 77 for selection of a pump.

Note: Pump-specific data can also be found on www.Grundfos.com (WebCAPS) by entering the product number 96871966.

For further information about WebCAPS, see page 98.

Custom-built variants

The pumps can be customised to meet individual requirements. Many pump features and options are available for customisation, such as explosion-proof versions, cable lengths or special materials.

Accessories

Depending on installation type and pump variant, accessories may be required. See section *Accessories*, page 92, for selection of the correct accessories.

Note: Ordered accessories are not fitted from factory.

Controller

The following controllers are available:

DP, EF, SL1 and SLV

- Dedicated Controls. See also page 93.
- LC and LCD 107 operated by air bells. See also page 94.
- LC and LCD 108 operated by float switches. See also page 94.
- LC and LCD 110 operated by electrodes. See also page 94.
- CU 100. See also page 95.

DP, EF, SL1 and SLV AUTO_{ADAPT}

- Built-in controller. See also page 4.
- Grundfos CIU unit. See also page 96.
- Grundfos R100 remote control. See also page 96.

Explosion-proof version

All pump ranges are available in explosion-proof versions.

The pumps are provided with a Europe CE 0344  II 2 G and Ex bcd IIB T4 Gb explosion protection classification according to EN 12050-1 and EN 12050-2.

The pumps are also available for IEC countries (Australia and others) with an Ex d IIB T4 Gb explosion protection classification according to IEC 60079-0 and IEC 60079-1.

Performance overview

Figure 4 shows the performance range of DP, EF, SL1 and SLV standard and AUTO_{ADAPT} pumps as well as the explosion-proof versions. It gives an overview of the various sizes and impeller types.

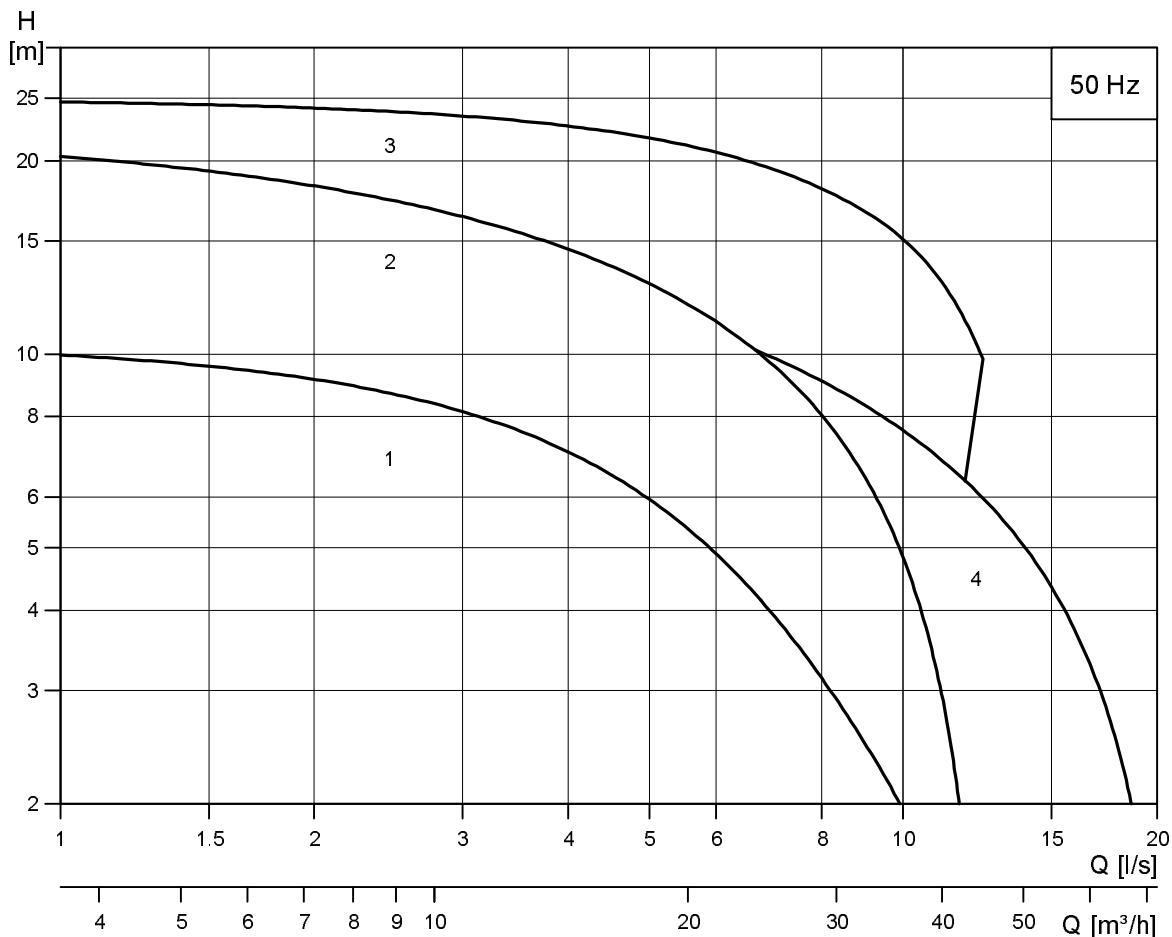

TM04 6698 0710

Fig. 4 Performance range

Pump type	Curve number
DP10	3
EF30	2
SL1.50.65.09	4
SL1.50.65.11	
SL1.50.65.15	
SLV.65.65.09	1
SLV.65.65.11	
SLV.65.65.15	

Standard pumps

DP10 standard

Pump type	Product number	Voltage [V]	Cable length [m]	Thermal protection
DP10.50.09.2.1.502	96104200	1 x 230 V D	10	Thermal switch
DP10.50.09.A.2.1.502	96104202	1 x 230 V D	10	Thermal switch
DP10.50.09.2.50B	96104204	3 x 400-415 V Y	10	Thermal switch
DP10.50.09.A.2.50B	96104206	3 x 400-415 V Y	10	Thermal switch
DP10.50.15.2.50B	96104208	3 x 400-415 V Y	10	Thermal switch
DP10.50.15.A.2.50B	96104210	3 x 400-415 V Y	10	Thermal switch
DP10.65.26.2.50B	96106542	3 x 400-415 V Y	10	Thermal switch
DP10.65.26.A.2.50B	96106544	3 x 400-415 V Y	10	Thermal switch

DP10 AUTO_{ADAPT}

Pump type	Product number	Voltage [V]	Cable length [m]	Thermal protection
DP10.50.09.E.2.1.502	96877476	1 x 230 V	10	Thermal switch
DP10.50.09.E.2.50B	96877478	3 x 400-415 V Y	10	Thermal switch
DP10.50.15.E.2.50B	96877503	3 x 400-415 V Y	10	Thermal switch
DP10.65.26.E.2.50B	96877506	3 x 400-415 V Y	10	Thermal switch

DP10 standard, Norway

Pump type	Product number	Voltage [V]	Cable length [m]	Thermal protection
DP10.50.09.2.50C	96566074	3 x 230-240 V D	10	Thermal switch
DP10.50.09.A.2.50C	96566075	3 x 230-240 V D	10	Thermal switch
DP10.50.15.2.50C	96566078	3 x 230-240 V D	10	Thermal switch
DP10.50.15.A.2.50C	96566079	3 x 230-240 V D	10	Thermal switch
DP10.65.26.2.50C	96566081	3 x 230-240 V D	10	Thermal switch
DP10.65.26.A.2.50C	96566082	3 x 230-240 V D	10	Thermal switch

EF30 standard

Pump type	Product number	Voltage [V]	Cable length [m]	Thermal protection
EF30.50.06.2.1.502	96106546	1 x 230 V D	10	Thermal switch
EF30.50.06.A.2.1.502	96106548	1 x 230 V D	10	Thermal switch
EF30.50.06.2.50B	96106550	3 x 400-415 V Y	10	Thermal switch
EF30.50.06.A.2.50B	96106552	3 x 400-415 V Y	10	Thermal switch
EF30.50.09.2.1.502	96115111	1 x 230 V D	10	Thermal switch
EF30.50.09.A.2.1.502	96115113	1 x 230 V D	10	Thermal switch
EF30.50.09.2.50B	96115115	3 x 400-415 V Y	10	Thermal switch
EF30.50.09.A.2.50B	96115117	3 x 400-415 V Y	10	Thermal switch
EF30.50.11.2.1.502	96106554	1 x 230 V D	10	Thermal switch
EF30.50.11.A.2.1.502	96106556	1 x 230 V D	10	Thermal switch
EF30.50.11.2.50B	96106558	3 x 400-415 V Y	10	Thermal switch
EF30.50.11.A.2.50B	96106560	3 x 400-415 V Y	10	Thermal switch
EF30.50.15.2.50B	96104196	3 x 400-415 V Y	10	Thermal switch
EF30.50.15.A.2.50B	96104198	3 x 400-415 V Y	10	Thermal switch

EF30 AUTO *ADAPT*

Pump type	Product number	Voltage [V]	Cable length [m]	Thermal protection
EF30.50.06.E.2.1.502	96877508	1 x 230 V	10	Thermal switch
EF30.50.06.E.2.50B	96877510	3 x 400-415 V Y	10	Thermal switch
EF30.50.09.E.2.1.502	96877515	1 x 230 V	10	Thermal switch
EF30.50.09.E.2.50B	96877516	3 x 400-415 V Y	10	Thermal switch
EF30.50.11.E.2.1.502	96875101	1 x 230 V	10	Thermal switch
EF30.50.11.E.2.50B	96878445	3 x 400-415 V Y	10	Thermal switch
EF30.50.15.E.2.50B	96878448	3 x 400-415 V Y	10	Thermal switch

EF30 standard, Norway

Pump type	Product number	Voltage [V]	Cable length [m]	Thermal protection
EF30.50.06.2.50C	96566084	3 x 230-240 V D	10	Thermal switch
EF30.50.06.A.2.50C	96566086	3 x 230-240 V D	10	Thermal switch
EF30.50.09.2.50C	96566088	3 x 230-240 V D	10	Thermal switch
EF30.50.11.2.50C	96566091	3 x 230-240 V D	10	Thermal switch
EF30.50.11.A.2.50C	96566092	3 x 230-240 V D	10	Thermal switch
EF30.50.15.2.50C	96566094	3 x 230-240 V D	10	Thermal switch
EF30.50.15.A.2.50C	96566095	3 x 230-240 V D	10	Thermal switch

SL1 standard

Pump type	Product number	Voltage [V]	Cable length [m]	Thermal protection
SL1.50.65.09.2.1.502	96106562	1 x 230 V D	10	Thermal switch
SL1.50.65.09.2.50C	96106567	3 x 230-240 V D	10	Thermal switch
SL1.50.65.09.2.50B	96106566	3 x 400-415 V Y	10	Thermal switch
SL1.50.65.09.A.2.1.502	96106564	1 x 230 V D	10	Thermal switch
SL1.50.65.09.A.2.50C	96106571	3 x 230-240 V D	10	Thermal switch
SL1.50.65.09.A.2.50B	96106570	3 x 400-415 V Y	10	Thermal switch
SL1.50.65.11.2.1.502	96104125	1 x 230 V D	10	Thermal switch
SL1.50.65.11.2.50C	96104130	3 x 230-240 V D	10	Thermal switch
SL1.50.65.11.2.50B	96104129	3 x 400-415 V Y	10	Thermal switch
SL1.50.65.11.A.2.1.502	96104127	1 x 230 V D	10	Thermal switch
SL1.50.65.11.A.2.50C	96104134	3 x 230-240 V D	10	Thermal switch
SL1.50.65.11.A.2.50B	96104133	3 x 400-415 V Y	10	Thermal switch
SL1.50.65.15.2.50C	96104119	3 x 230-240 V D	10	Thermal switch
SL1.50.65.15.2.50B	96104118	3 x 400-415 V Y	10	Thermal switch
SL1.50.65.15.A.2.50C	96104123	3 x 230-240 V D	10	Thermal switch
SL1.50.65.15.A.2.50B	96104122	3 x 400-415 V Y	10	Thermal switch

SL1 AUTO_{ADAPT}

Pump type	Product number	Voltage [V]	Cable length [m]	Thermal protection
SL1.50.65.09.E.2.1.502	96878450	1 x 230 V	10	Thermal switch
SL1.50.65.09.E.2.50B	96878451	3 x 400-415 V Y	10	Thermal switch
SL1.50.65.11.E.2.1.502	96878454	1 x 230 V	10	Thermal switch
SL1.50.65.11.E.2.50B	96878455	3 x 400-415 V Y	10	Thermal switch
SL1.50.65.15.E.2.50B	96878458	3 x 400-415 V Y	10	Thermal switch

SL1 standard, Norway

Pump type	Product number	Voltage [V]	Cable length [m]	Thermal protection
SL1.50.65.09.2.50C	96106567	3 x 230-240 V D	10	Thermal switch
SL1.50.65.09.A.2.50C	96106571	3 x 230-240 V D	10	Thermal switch
SL1.50.65.11.2.50C	96104130	3 x 230-240 V D	10	Thermal switch
SL1.50.65.11.A.2.50C	96104134	3 x 230-240 V D	10	Thermal switch
SL1.50.65.15.2.50C	96104119	3 x 230-240 V D	10	Thermal switch
SL1.50.65.15.A.2.50C	96104123	3 x 230-240 V D	10	Thermal switch

SLV standard

Pump type	Product number	Voltage [V]	Cable length [m]	Thermal protection
SLV65.65.09.2.1.502	96115119	1 x 230 V D	10	Thermal switch
SLV65.65.09.2.50B	96115123	3 x 400-415 V Y	10	Thermal switch
SLV65.65.09.A.2.1.502	96115121	1 x 230 V D	10	Thermal switch
SLV65.65.09.A.2.50B	96115125	3 x 400-415 V Y	10	Thermal switch
SLV65.65.11.2.1.502	96106573	1 x 230 V D	10	Thermal switch
SLV65.65.11.2.50B	96106577	3 x 400-415 V Y	10	Thermal switch
SLV65.65.11.A.2.1.502	96106575	1 x 230 V D	10	Thermal switch
SLV65.65.11.A.2.50B	96106579	3 x 400-415 V Y	10	Thermal switch
SLV65.65.15.2.50B	96104192	3 x 400-415 V Y	10	Thermal switch
SLV65.65.15.A.2.50B	96104194	3 x 400-415 V Y	10	Thermal switch

SLV AUTO_{ADAPT}

Pump type	Product number	Voltage [V]	Cable length [m]	Thermal protection
SLV65.65.09.E.2.1.502	96878474	1 x 230 V	10	Thermal switch
SLV65.65.09.E.2.50B	96878475	3 x 400-415 V Y	10	Thermal switch
SLV65.65.11.E.2.1.502	96882685	1 x 230 V	10	Thermal switch
SLV65.65.11.E.2.50B	96882686	3 x 400-415 V Y	10	Thermal switch
SLV65.65.15.E.2.50B	96878503	3 x 400-415 V Y	10	Thermal switch

Explosion-proof pumps

DP10 Ex

Pump type	Product number	Voltage [V]	Cable length [m]	Thermal protection
DP10.50.09.Ex.2.1.502	96104201	1 x 230 V D	10	Thermal switch
DP10.50.09.Ex.2.50B	96104205	3 x 400-415 V Y	10	Thermal switch
DP10.50.15.Ex.2.50B	96104209	3 x 400-415 V Y	10	Thermal switch
DP10.65.26.Ex.2.50B	96106543	3 x 400-415 V Y	10	Thermal switch

DP10 AUTO_{ADAPT} Ex

Pump type	Product number	Voltage [V]	Cable length [m]	Thermal protection
DP10.50.09.E.Ex.2.1.502	96877479	1 x 230 V	10	Thermal switch
DP10.50.09.E.Ex.2.50B	96877502	3 x 400-415 V Y	10	Thermal switch
DP10.50.15.E.Ex.2.50B	96877504	3 x 400-415 V Y	10	Thermal switch
DP10.65.26.E.Ex.2.50B	96877507	3 x 400-415 V Y	10	Thermal switch

DP10 Ex, Norway

Pump type	Product number	Voltage [V]	Cable length [m]	Thermal protection
DP10.50.09.Ex.2.50C	96566076	3 x 230-240 V D	10	Thermal switch
DP10.50.15.Ex.2.50C	96566080	3 x 230-240 V D	10	Thermal switch
DP10.65.26.Ex.2.50C	96566083	3 x 230-240 V D	10	Thermal switch

DP10 Ex, Australia

Pump type	Product number	Voltage [V]	Cable length [m]	Thermal protection
DP10.50.09.Ex.2.1.502	96104203	1 x 230 V D	10	Thermal switch
DP10.50.09.Ex.2.50B	96104207	3 x 400-415 V Y	10	Thermal switch
DP10.50.15.Ex.2.50B	96104211	3 x 400-415 V Y	10	Thermal switch
DP10.65.26.Ex.2.50B	96106545	3 x 400-415 V Y	10	Thermal switch

EF30 Ex

Pump type	Product number	Voltage [V]	Cable length [m]	Thermal protection
EF30.50.06.Ex.2.1.502	96106547	1 x 230 V D	10	Thermal switch
EF30.50.06.Ex.2.50B	96106551	3 x 400-415 V Y	10	Thermal switch
EF30.50.09.Ex.2.1.502	96115112	1 x 230 V D	10	Thermal switch
EF30.50.09.Ex.2.50B	96115116	3 x 400-415 V Y	10	Thermal switch
EF30.50.11.Ex.2.1.502	96106555	1 x 230 V D	10	Thermal switch
EF30.50.11.Ex.2.50B	96106559	3 x 400-415 V Y	10	Thermal switch
EF30.50.15.Ex.2.50B	96104197	3 x 400-415 V Y	10	Thermal switch

EF30 AUTO_{ADAPT} Ex

Pump type	Product number	Voltage [V]	Cable length [m]	Thermal protection
EF30.50.06.E.Ex.2.1.502	96877512	1 x 230 V	10	Thermal switch
EF30.50.06.E.Ex.2.50B	96877514	3 x 400-415 V Y	10	Thermal switch
EF30.50.09.E.Ex.2.1.502	96877518	1 x 230 V	10	Thermal switch
EF30.50.09.E.Ex.2.50B	96877532	3 x 400-415 V Y	10	Thermal switch
EF30.50.11.E.Ex.2.1.502	96878446	1 x 230 V	10	Thermal switch
EF30.50.11.E.Ex.2.50B	96878447	3 x 400-415 V Y	10	Thermal switch
EF30.50.15.E.Ex.2.50B	96878449	3 x 400-415 V Y	10	Thermal switch

EF30 Ex, Norway

Pump type	Product number	Voltage [V]	Cable length [m]	Thermal protection
EF30.50.06.Ex.2.50C	96566087	3 x 230-240 V D	10	Thermal switch
EF30.50.09.Ex.2.50C	96566090	3 x 230-240 V D	10	Thermal switch
EF30.50.11.Ex.2.50C	96566093	3 x 230-240 V D	10	Thermal switch
EF30.50.15.Ex.2.50C	96566096	3 x 230-240 V D	10	Thermal switch

EF30 Ex, Australia

Pump type	Product number	Voltage [V]	Cable length [m]	Thermal protection
EF30.50.Ex.06.2.1.502	96106549	1 x 230 V D	10	Thermal switch
EF30.50.Ex.06.2.50B	96106553	3 x 400-415 V Y	10	Thermal switch
EF30.50.Ex.09.2.1.502	96115114	1 x 230 V D	10	Thermal switch
EF30.50.Ex.09.2.50B	96115118	3 x 400-415 V Y	10	Thermal switch
EF30.50.Ex.11.2.1.502	96106557	1 x 230 V D	10	Thermal switch
EF30.50.Ex.11.2.50B	96106561	3 x 400-415 V Y	10	Thermal switch
EF30.50.Ex.15.2.50B	96104199	3 x 400-415 V Y	10	Thermal switch

SL1 Ex

Pump type	Product number	Voltage [V]	Cable length [m]	Thermal protection
SL1.50.65.09.Ex.2.1.502	96106563	1 x 230 V D	10	Thermal switch
SL1.50.65.09.Ex.2.50C	96106569	3 x 230-240 V D	10	Thermal switch
SL1.50.65.09.Ex.2.50B	96106568	3 x 400-415 V Y	10	Thermal switch
SL1.50.65.11.Ex.2.1.502	96104126	1 x 230 V D	10	Thermal switch
SL1.50.65.11.Ex.2.50C	96104132	3 x 230-240 V D	10	Thermal switch
SL1.50.65.11.Ex.2.50B	96104131	3 x 400-415 V Y	10	Thermal switch
SL1.50.65.15.Ex.2.50C	96104121	3 x 230-240 V D	10	Thermal switch
SL1.50.65.15.Ex.2.50B	96104120	3 x 400-415 V Y	10	Thermal switch

SL1 AUTO_{ADAPT} Ex

Pump type	Product number	Voltage [V]	Cable length [m]	Thermal protection
SL1.50.65.09.E.Ex.2.1.502	96878452	1 x 230 V	10	Thermal switch
SL1.50.65.09.E.Ex.2.50B	96878453	3 x 400-415 V Y	10	Thermal switch
SL1.50.65.11.E.Ex.2.1.502	96878456	1 x 230 V	10	Thermal switch
SL1.50.65.11.E.Ex.2.50B	96878457	3 x 400-415 V Y	10	Thermal switch
SL1.50.65.15.E.Ex.2.50B	96878472	3 x 400-415 V Y	10	Thermal switch

SL1 Ex, Norway

Pump type	Product number	Voltage [V]	Cable length [m]	Thermal protection
SL1.50.65.09.Ex.2.50C	96106569	3 x 230-240 V D	10	Thermal switch
SL1.50.65.11.Ex.2.50C	96104132	3 x 230-240 V D	10	Thermal switch
SL1.50.65.15.Ex.2.50C	96104121	3 x 230-240 V D	10	Thermal switch

SL1 Ex, Australia

Pump type	Product number	Voltage [V]	Cable length [m]	Thermal protection
SL1.50.65.09.Ex.2.1.502	96106565	1 x 230 V D	10	Thermal switch
SL1.50.65.09.Ex.2.50B	96106572	3 x 400-415 V Y	10	Thermal switch
SL1.50.65.11.Ex.2.1.502	96104128	1 x 230 V D	10	Thermal switch
SL1.50.65.11.Ex.2.50B	96104135	3 x 400-415 V Y	10	Thermal switch
SL1.50.65.15.Ex.2.50B	96104124	3 x 400-415 V Y	10	Thermal switch

SLV Ex

Pump type	Product number	Voltage [V]	Cable length [m]	Thermal protection
SLV65.65.09.Ex.2.1.502	96115120	1 x 230 V D	10	Thermal switch
SLV65.65.09.Ex.2.50B	96115124	3 x 400-415 V Y	10	Thermal switch
SLV65.65.11.Ex.2.1.502	96106574	1 x 230 V D	10	Thermal switch
SLV65.65.11.Ex.2.50B	96106578	3 x 400-415 V Y	10	Thermal switch
SLV.65.65.15.Ex.2.50B	96104193	3 x 400-415 V Y	10	Thermal switch

SLV AUTO_{ADAPT} Ex

Pump type	Product number	Voltage [V]	Cable length [m]	Thermal protection
SLV65.65.09.E.Ex.2.1.502	96878476	1 x 230 V	10	Thermal switch
SLV65.65.09.E.Ex.2.50B	96878477	3 x 400-415 V Y	10	Thermal switch
SLV65.65.11.E.Ex.2.1.502	96878480	1 x 230 V	10	Thermal switch
SLV65.65.11.E.Ex.2.50B	96878481	3 x 400-415 V Y	10	Thermal switch
SLV65.65.15.E.Ex.2.50B	96878504	3 x 400-415 V Y	10	Thermal switch

SLV Ex, Australia

Pump type	Product number	Voltage [V]	Cable length [m]	Thermal protection
SLV.65.65.Ex.09.2.1.502	96115122	1 x 230 V D	10	Thermal switch
SLV.65.65.Ex.09.2.50B	96115126	3 x 400-415 V Y	10	Thermal switch
SLV.65.65.Ex.11.2.1.502	96106576	1 x 230 V D	10	Thermal switch
SLV.65.65.Ex.11.2.50B	96106580	3 x 400-415 V Y	10	Thermal switch
SLV.65.65.Ex.15.2.50B	96104195	3 x 400-415 V Y	10	Thermal switch

List of variants

Motor		
		15 m
		20 m
Standard cables	Cable B, 4 G 1.5 mm ² + 3 x 1 mm ²	25 m
		30 m
		40 m
		50 m
Ex cables	Cable B, 4 G 1.5 mm ² + 3 x 1 mm ² , Ex	15 m
		20 m
		25 m
		30 m
		40 m
		50 m
Screened power cables for frequency converters	Screened cable B, Ex	10 m
		15 m
		20 m
		25 m
		30 m
		40 m
Cable protection	For 7-core cable	
Special motor	Special voltage With or without PTC, etc.	

Tests

Test at specified duty on standard impeller curve		
Trimmed impeller for specified duty test		
Additional test of entire QH curve (including report)	5 to 10 flows from pump performance curve.	
Different test standard	Efficiency guaranteed by Grundfos.	ISO 9906 grade 1 tolerances. ISO 9906 grade 2 tolerances.
Vibration test (including report)	According to Grundfos factory quality standard.	
NPSHr test	Not yet available.	
String test	Contact Grundfos.	
Witness test	Contact Grundfos.	

Certificates

ATEX-approved pump report	Special Grundfos report. Contact Grundfos.	
Certificate of compliance with order	According to EN 10204 2.1.	According to Annex A grades 1 and 2.
Pump certificate	According to EN 10204 2.2.	According to Annex A grades 1 and 2.
Inspection certificate	According to EN 10204 3.1.	According to Annex A grades 1 and 2.
Material specification report	According to EN 10204 3.1B.	
Material report with certificate	According to EN 10204 3.2.	Material supplier information.
Inspection certificate Lloyds Register	According to EN 10204 3.2.	
Inspection certificate DNV (Det Norske Veritas)	According to EN 10204 3.2.	
Inspection certificate Germanischer Lloyd	According to EN 10204 3.2.	
Inspection certificate American Bureau of Shipping	According to EN 10204 3.2.	
Inspection certificate Bureau Veritas	According to EN 10204 3.2.	
Registro Italiano Navale Argenteure	According to EN 10204 3.2.	
Other 3rd party test certificate	Contact Grundfos.	

Miscellaneous

Special packaging	Contact Grundfos.
Special nameplate	Contact Grundfos.
Other variants	Contact Grundfos.
Chemical-resistant shaft seal	FKM, standard (NBR).
Chemical-resistant pump	FKM, standard (NBR).
Internal surface treatment	Ceramic coating (impeller and pump housing). Extra epoxy (CED) coating.
Top coating	Black (RAL 9005), red (RAL 3000). Other colour.

Material specification, DP and EF pumps

The position numbers in the table below refer to the sectional drawings and exploded views on the following pages.

Pos.	Description	Material	EN standard	AISI/ASTM
6a	Pin	Stainless steel		
7a	Rivet	Stainless steel	1.4301	304
9a	Key	Stainless steel		
26a	O-ring	NBR		
37	O-ring	NBR		
37a	O-rings	NBR		
37b	O-rings	NBR		
48	Stator			
48a	Cover			
49	Impeller	Cast iron	EN-GJS-500-7	
50	Pump housing	Cast iron	EN-GJL-250	
55	Stator housing	Cast iron	EN-JL-1030	
58	Shaft seal carrier	Cast iron	EN-JL-1030	
66	Locking ring	Stainless steel		
76	Nameplate	Stainless steel	1.4301	304
84	Strainer*	Cast iron		
92	Clamp	Stainless steel	1.4301	304
102	O-ring	NBR		
103	Bush	Stainless steel	1.4057	431
104	Seal ring	NBR		
105	Shaft seal			
105a	Shaft seal			
107	O-rings	NBR		
150a	Stator in housing complete			
153	Bearing	6204		
153a	Washer			
153b	Washer			
154	Bearing	6303		
155	Oil chamber	Cast iron		
157	Washer			
158	Corrugated spring	Steel		
159	O-ring	NBR		
162	Wear plate	Cast iron		
172	Rotor Shaft		1.0533 1.4301	304
173	Screw	Steel		
173a	Washer	Steel		
176	Inner plug part	PET		
181	Outer plug part	CR rubber, cable H07RN-F	1.4308	CF-8
188a	Screw	Stainless steel		
188b	Locking screw			
188c	Locking screw			
189	Adjusting screw			
190	Lifting bracket	Stainless steel	1.4308	CF-8
193	Oil screw	Stainless steel		
193a	Oil	Shell Ondina 917		
194	Gasket	Nylon		
198	O-ring	NBR		
	Paint	Two-component epoxy		

* Only DP pumps

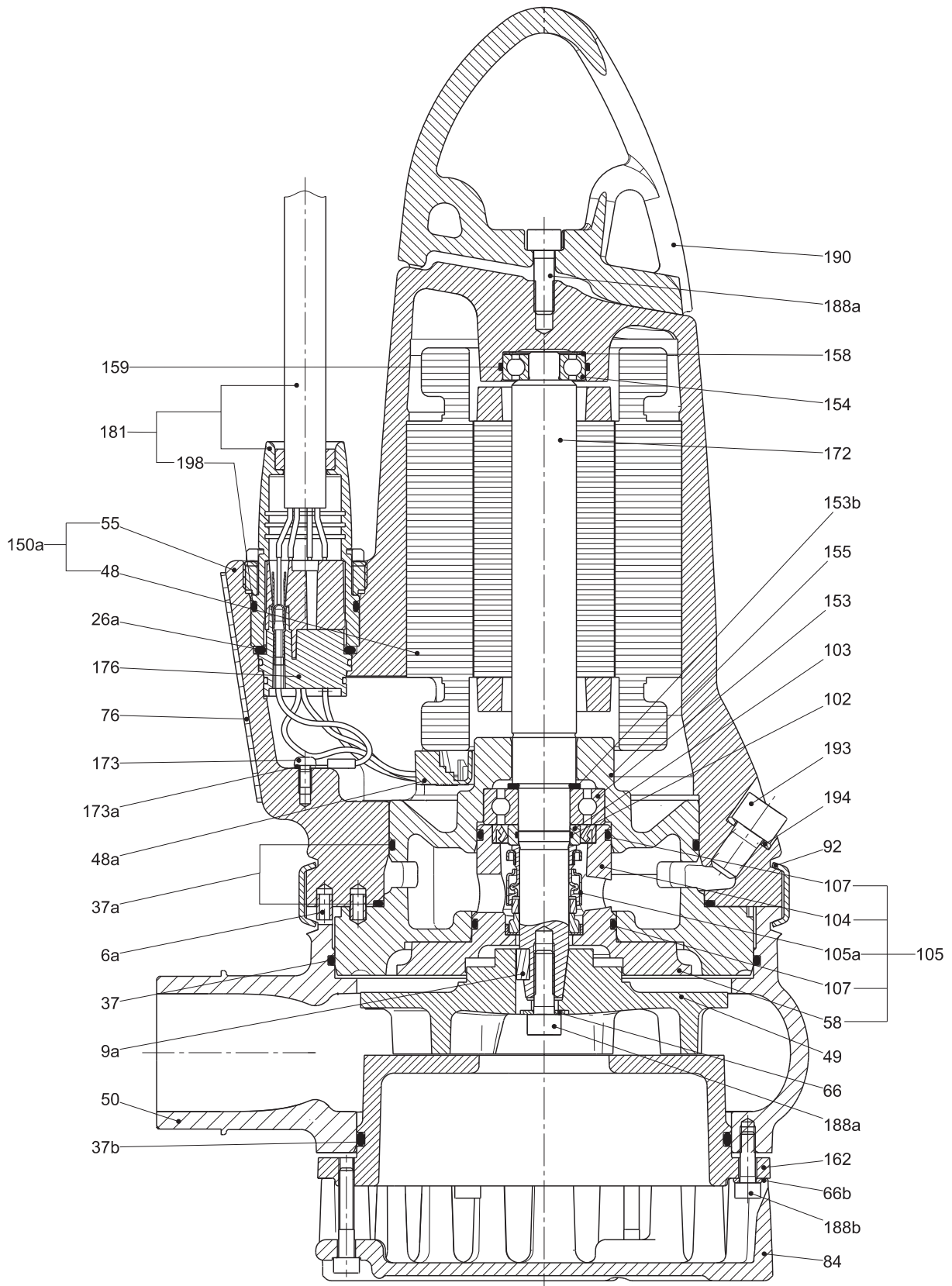

Fig. 5 Sectional drawing, DP10.50.09/15

TM02 7230 3209

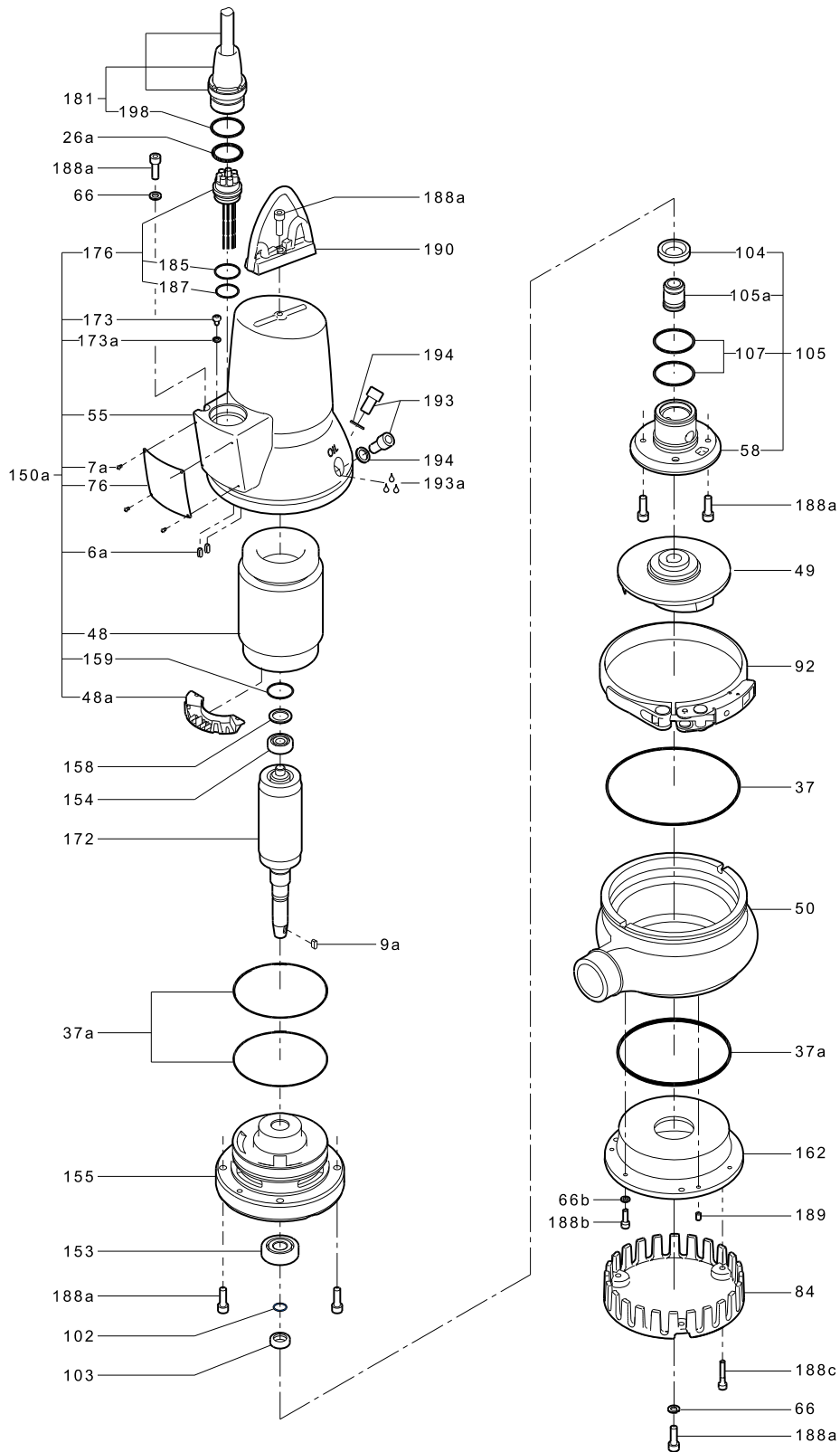

Fig. 6 Exploded view, DP10.50.09/15

TM02 7229 3009

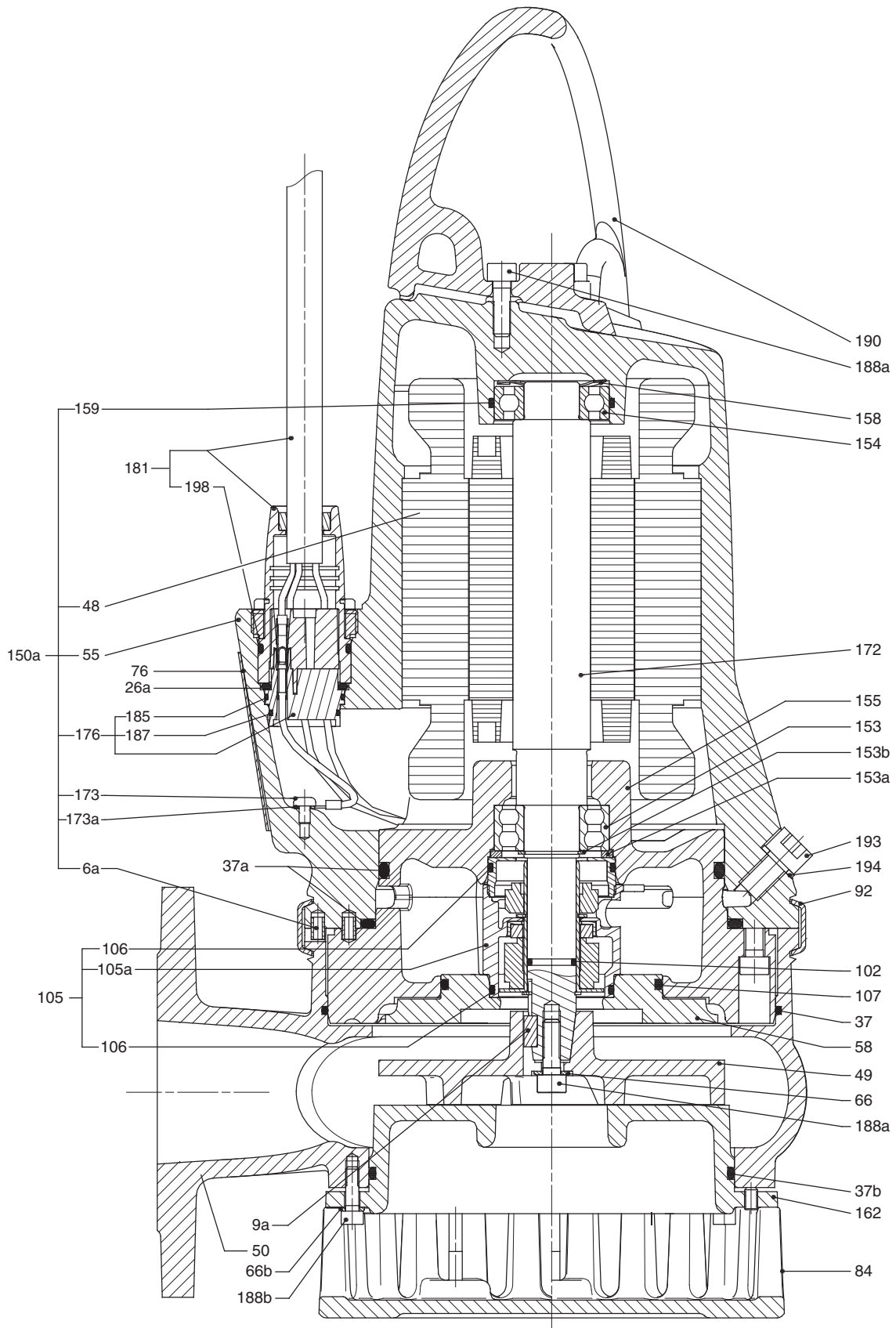

Fig. 7 Sectional drawing, DP10.65.26

TM02 7233 0904

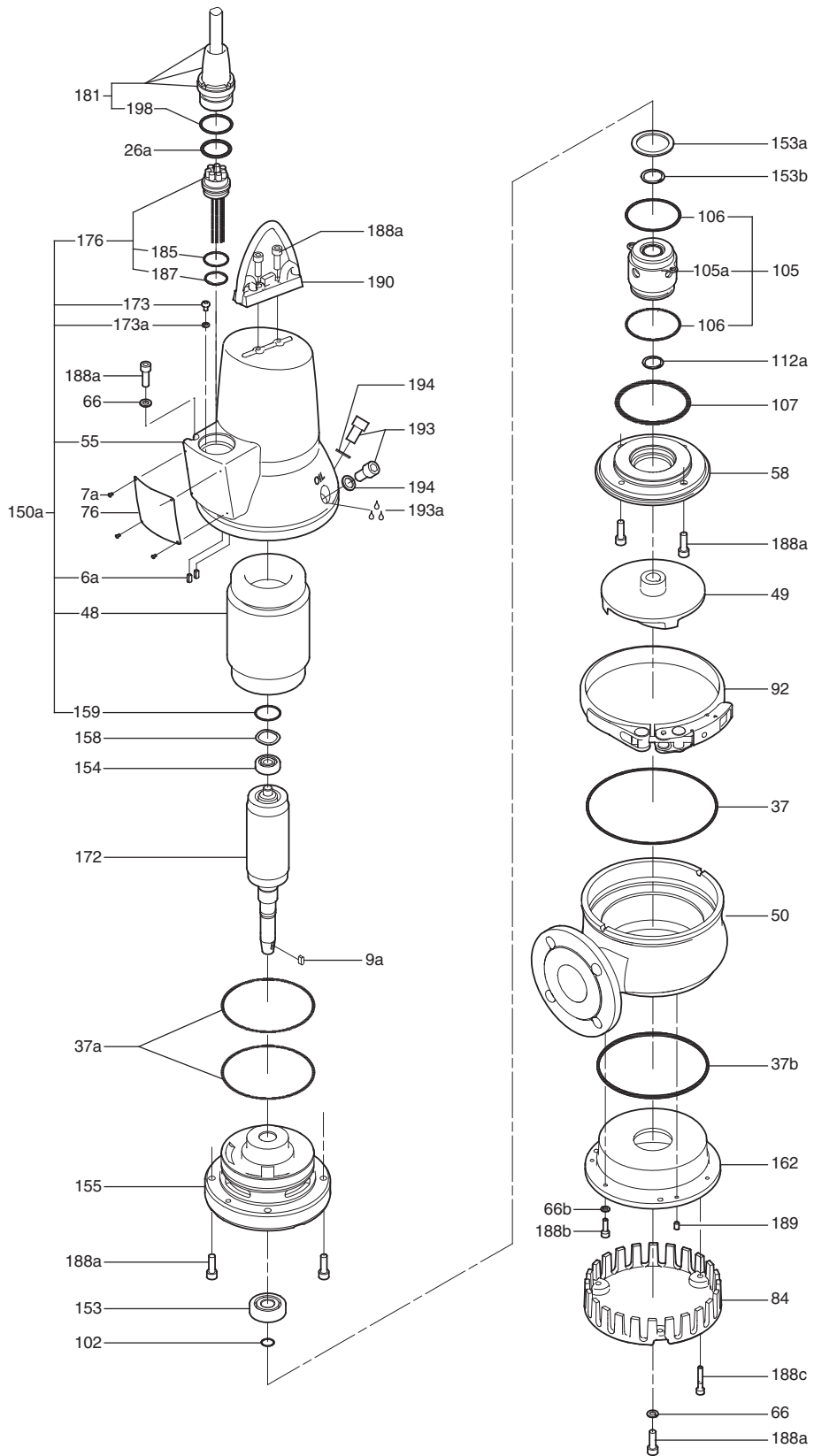

Fig. 8 Exploded view, DP10.65.26

TM02 7232 0904

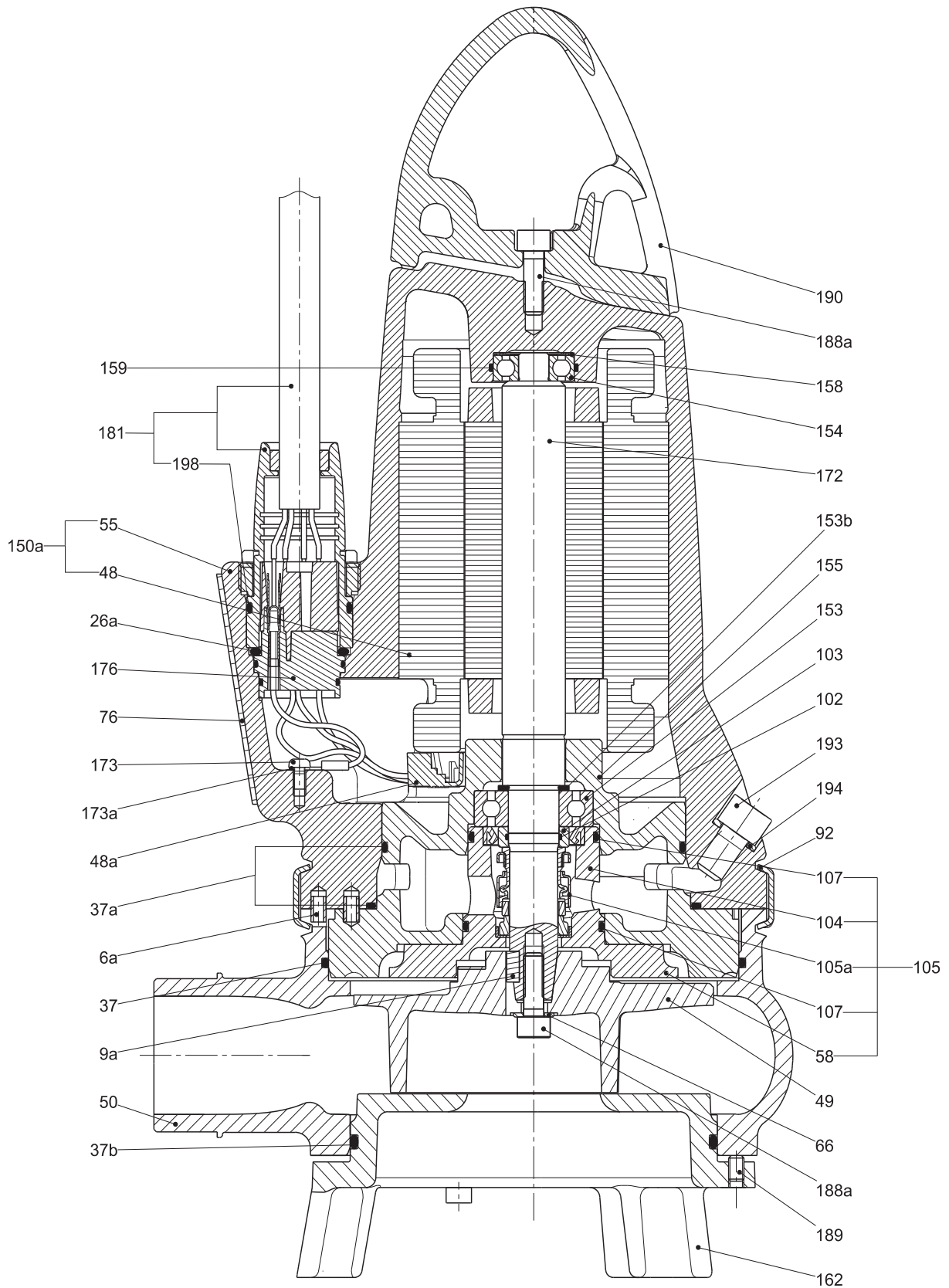

Fig. 9 Sectional drawing, EF

TM02 7359 3209

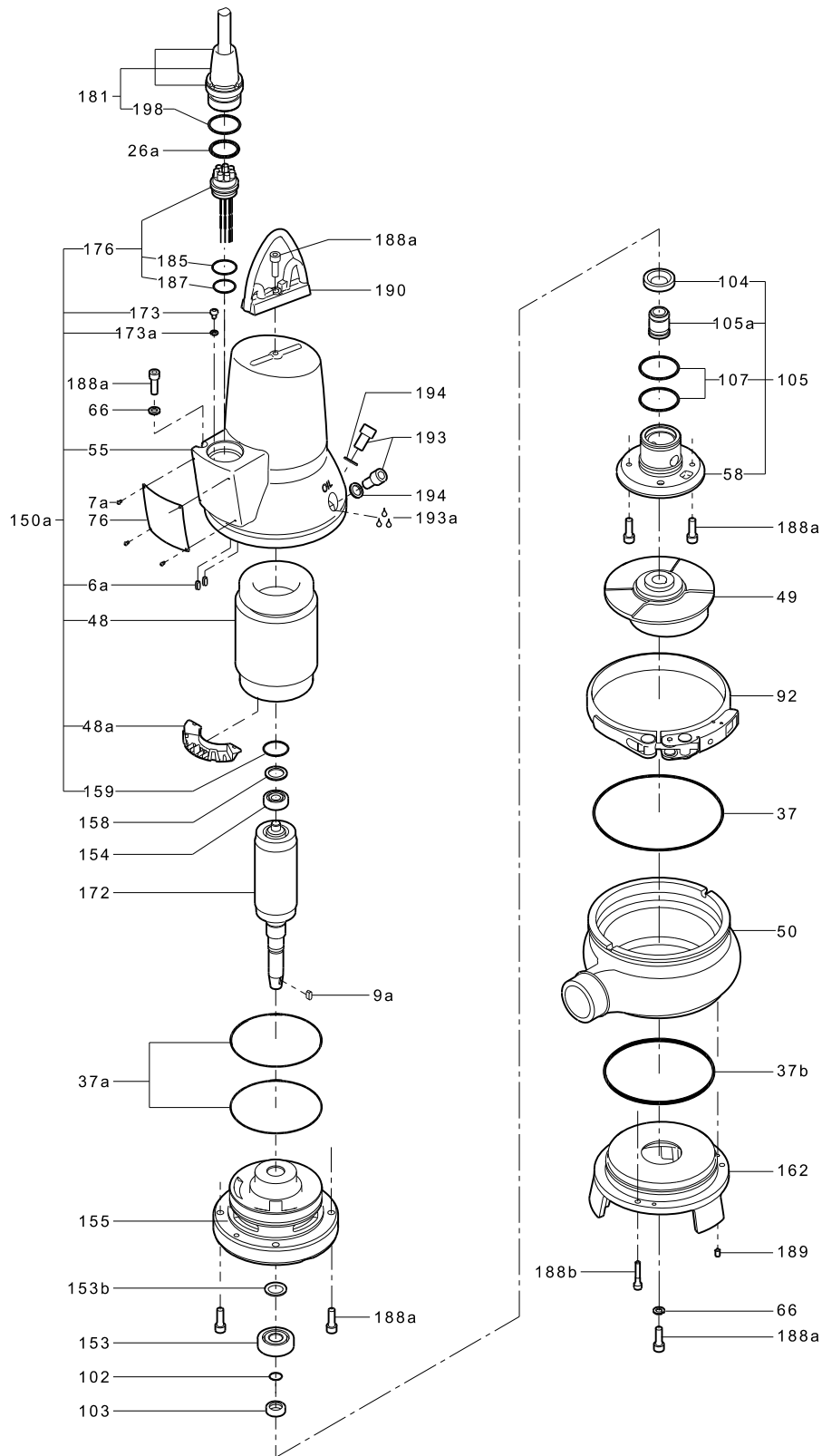

Fig. 10 Exploded view, EF

TM02 7362 3009

Material specification, DP10 and EF AUTO_{ADAPT} pumps

The position numbers in the table below refer to the sectional drawings and exploded views on the following pages.

Pos.	Description	Material	EN standard	AISI/ASTM
6a	Pin	Stainless steel		
7a	Rivet	Stainless steel		
9a	Key	Stainless steel		
26A	O-ring			
37	O-ring			
37a	O-rings	NBR		
37b	O-ring			
48	Stator			
48a	Terminal board			
49	Impeller	Cast iron	EN-JL-1030	
50	Pump housing	Cast iron	EN-JL-1030	
55	Stator housing	Cast iron	EN-JL-1030	
58	Shaft seal carrier	Cast iron	EN-JL-1030	
66	Locking ring	Stainless steel		
76	Nameplate	Stainless steel	1.4301	304
84	Suction strainer***	Cast iron		
90a	Electronic unit			
90b	O-ring			
92	Clamp	Stainless steel	1.4301	304
102	O-ring	NBR		
103	Bush	Stainless steel	1.4057	431
104	Seal ring	NBR		
105/105a	Shaft seal	Primary seal (0.6 to 1.5 kW): SiC/SiC Secondary seal (0.6 to 1.5 kW): lip seal, NBR Primary seal (2.6 kW): SiC/SiC Secondary seal (2.6 kW): carbon/aluminium oxide Other components: NBR, stainless steel		
107	O-rings	NBR		
153	Bearing	Up to and including 1.5 kW: 6303 2.6 kW and up: 3205		
154	Bearing	Up to and including 1.5 kW: 6201 2.6 kW and up: 6205		
155	Oil chamber			
158	Corrugated spring	Steel		
159	O-ring	NBR		
161	Operating capacitor*			
161b	Nut			
161c	Bracket			
161d	Washer			
161e	Washer			
161f	Screw	Steel		
172	Rotor/shaft	Shaft part at rotor: steel Shaft end at hydraulics: stainless steel	1.0533 1.4301	304
173	Screw	Steel		
173a	Washer	Steel		
174	Earth screw			
174a	Washer			
176	Inner plug part	PET		
181	Outer plug part	CR rubber, cable H07RN-F	1.4308	CF-8
188a	Screw	Stainless steel		
188b	Locking screw	Steel		
188c	Screw	Steel		
189	Adjusting screw	Steel		
190	Lifting bracket	Stainless steel	1.4308	CF-8
193	Oil screw	Stainless steel		

Pos.	Description	Material	EN standard	AISI/ASTM
193a	Oil	Shell Ondina 913		
194	Gasket	Nylon		
198	O-ring	NBR		
285	Dry-running sensors**			
285a	O-ring	NBR	1.4308	CF-8
285b	Set screw			
287	Level sensor			
287a	Protection cap			
287b	O-ring			
287c	Set screw			
288	Pt1000 sensor			
	Paint	Two-component epoxy		

* Single-phase pumps only.

** Explosion-proof pumps have two dry-running sensors.

*** DP pumps only.

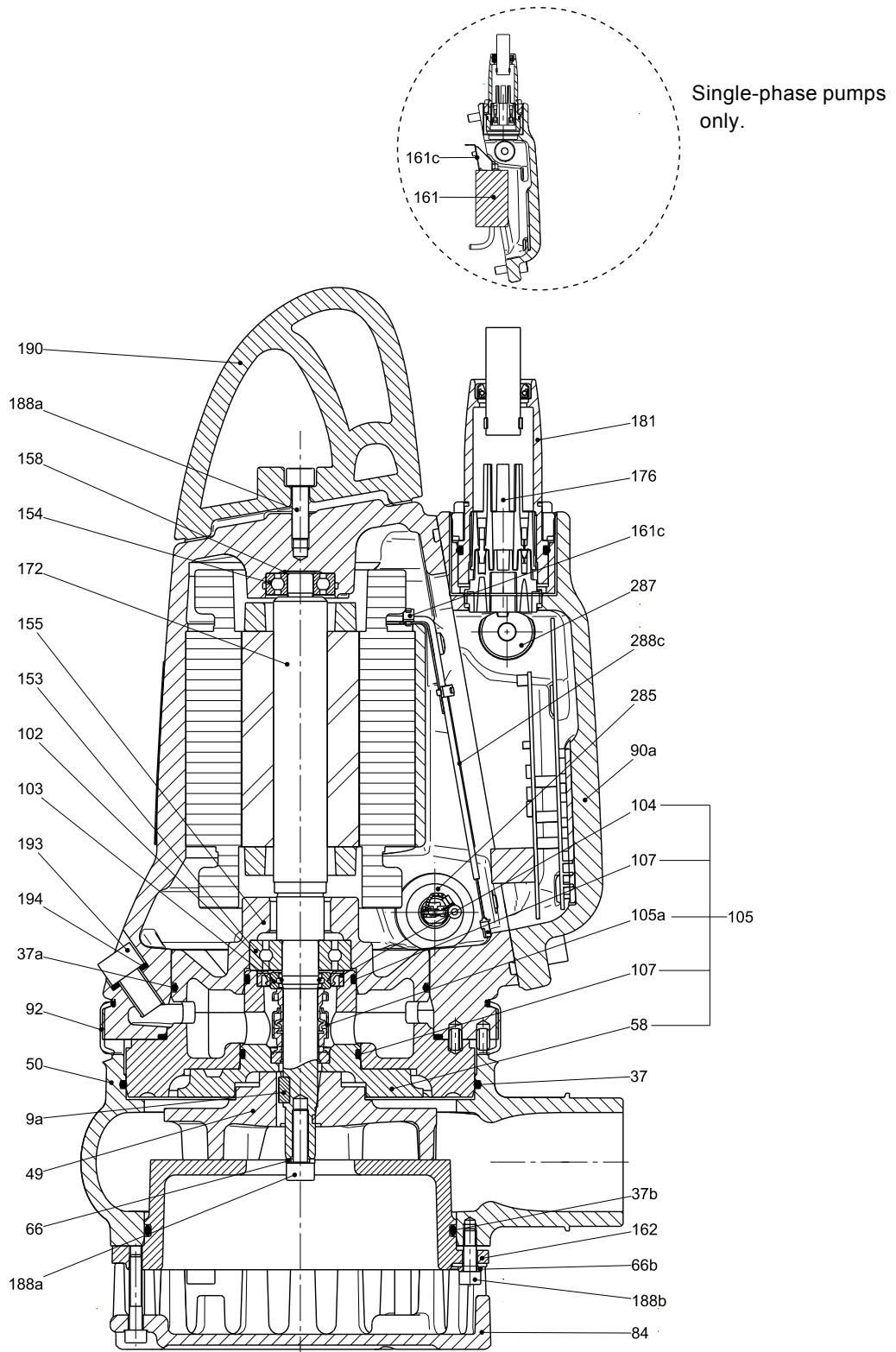
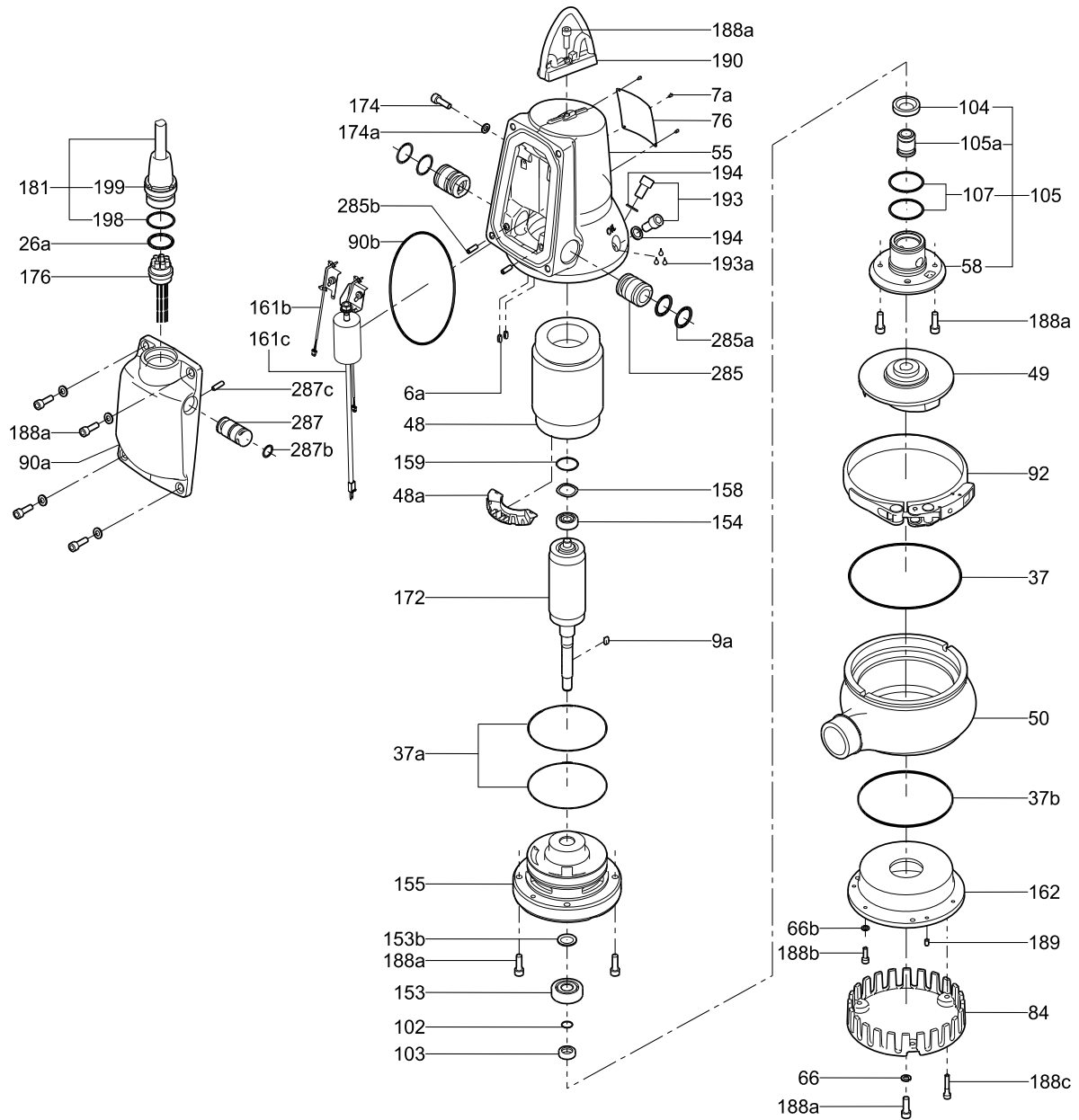

Fig. 11 Sectional drawing, DP10.50.09/15 AUTO_{ADAPT}

TM04 5989 4609



TMD4 4868 2109

Fig. 12 Exploded view, DP10.50.09/15 AUTOADAPT

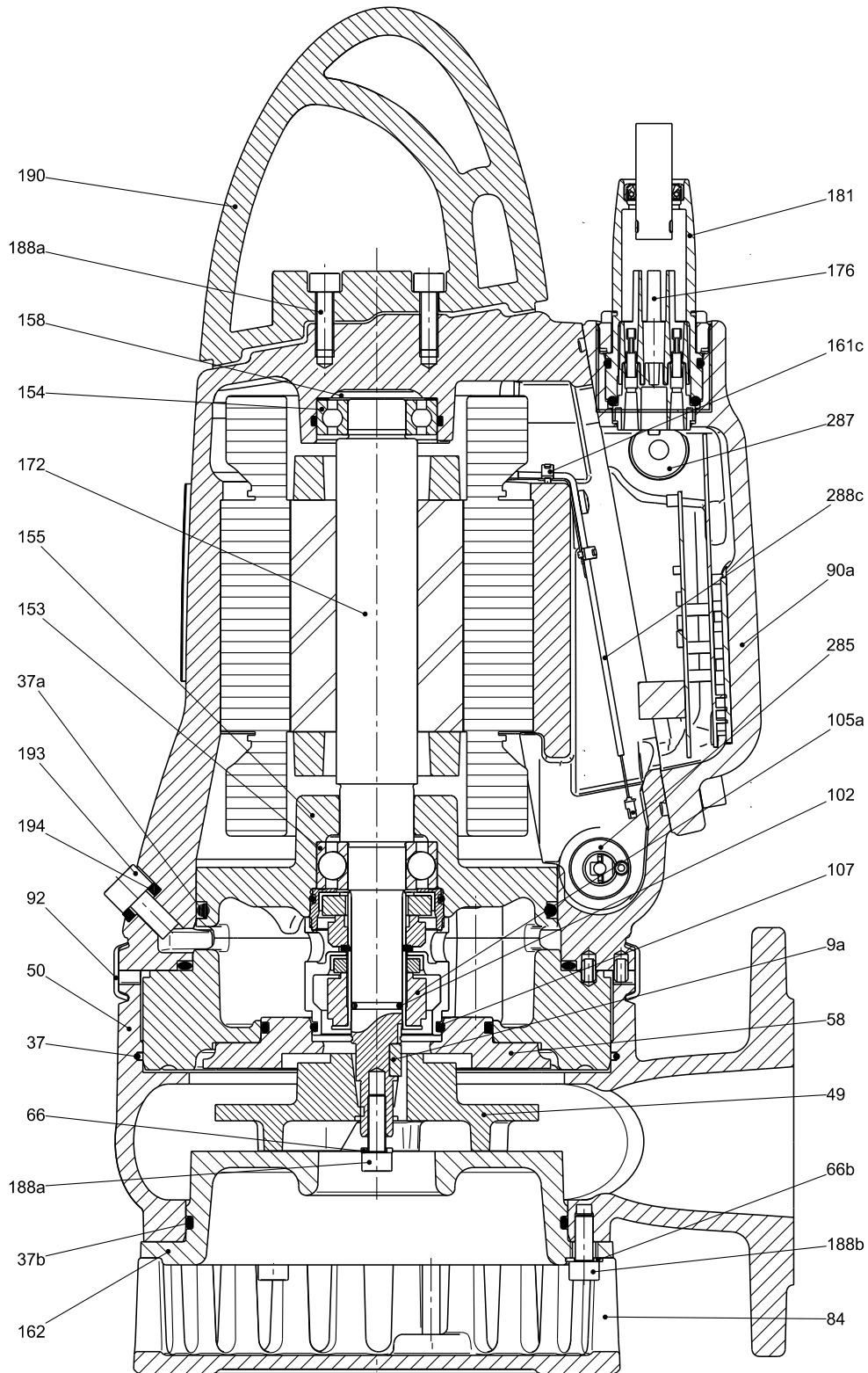

Fig. 13 Sectional drawing, DP10.65.26 AUTO_{ADAPT}

TM04 5931 4609

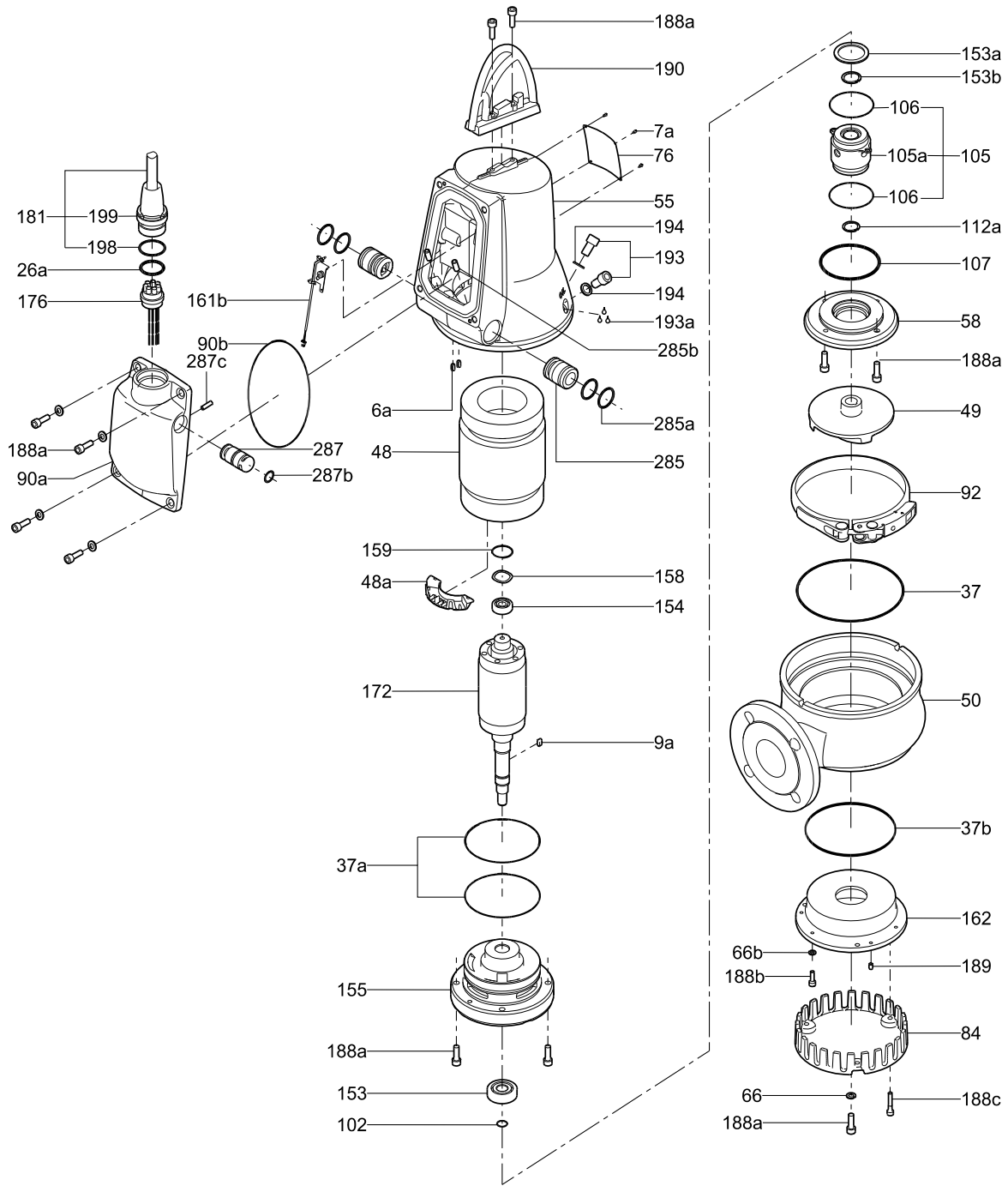

Fig. 14 Exploded view, DP10.65.26 AUTO_{ADAPT}

TM04 4869 2109

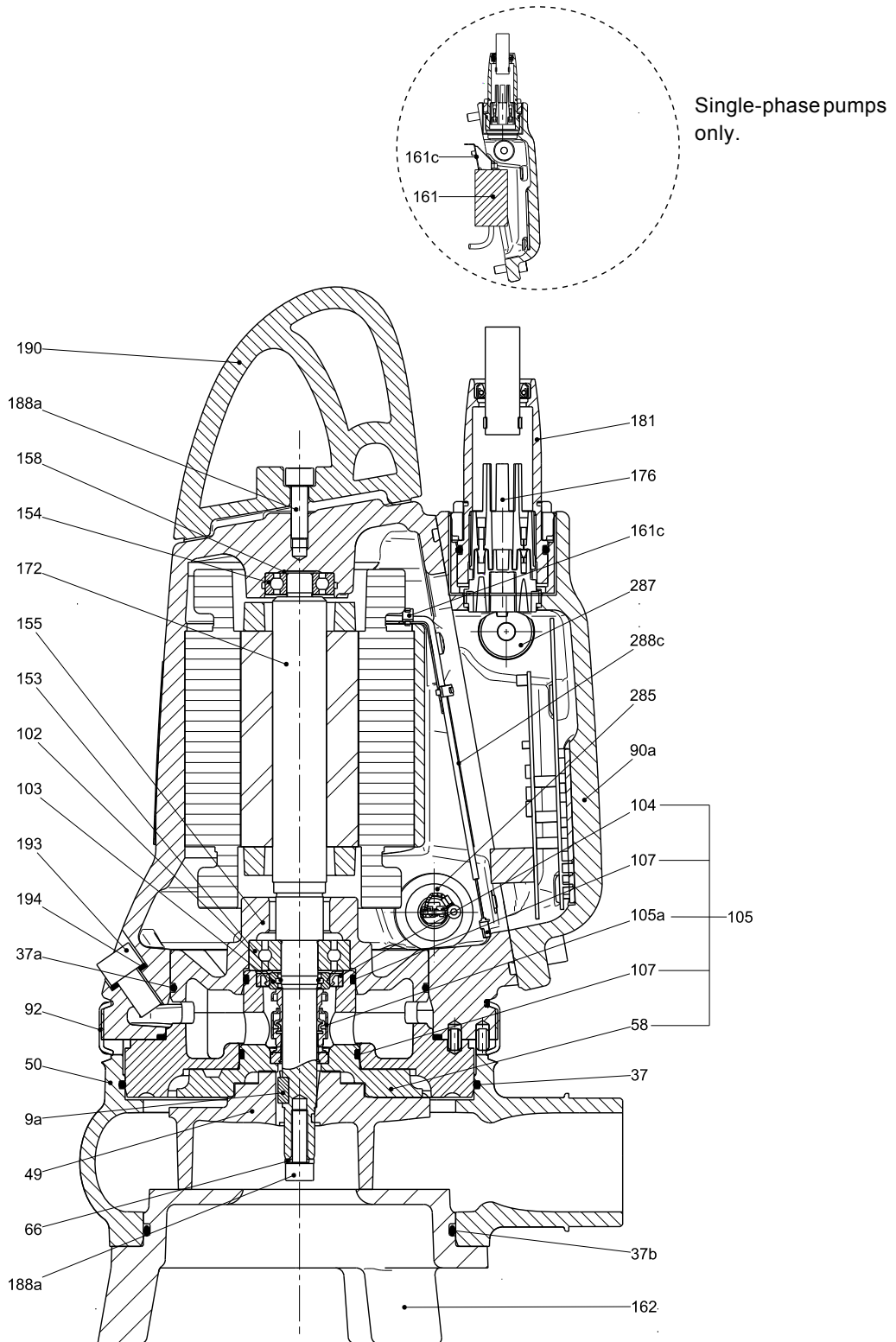

Fig. 15 Sectional drawing, EF AUTO_{ADAPT}

TM04 5993 4609

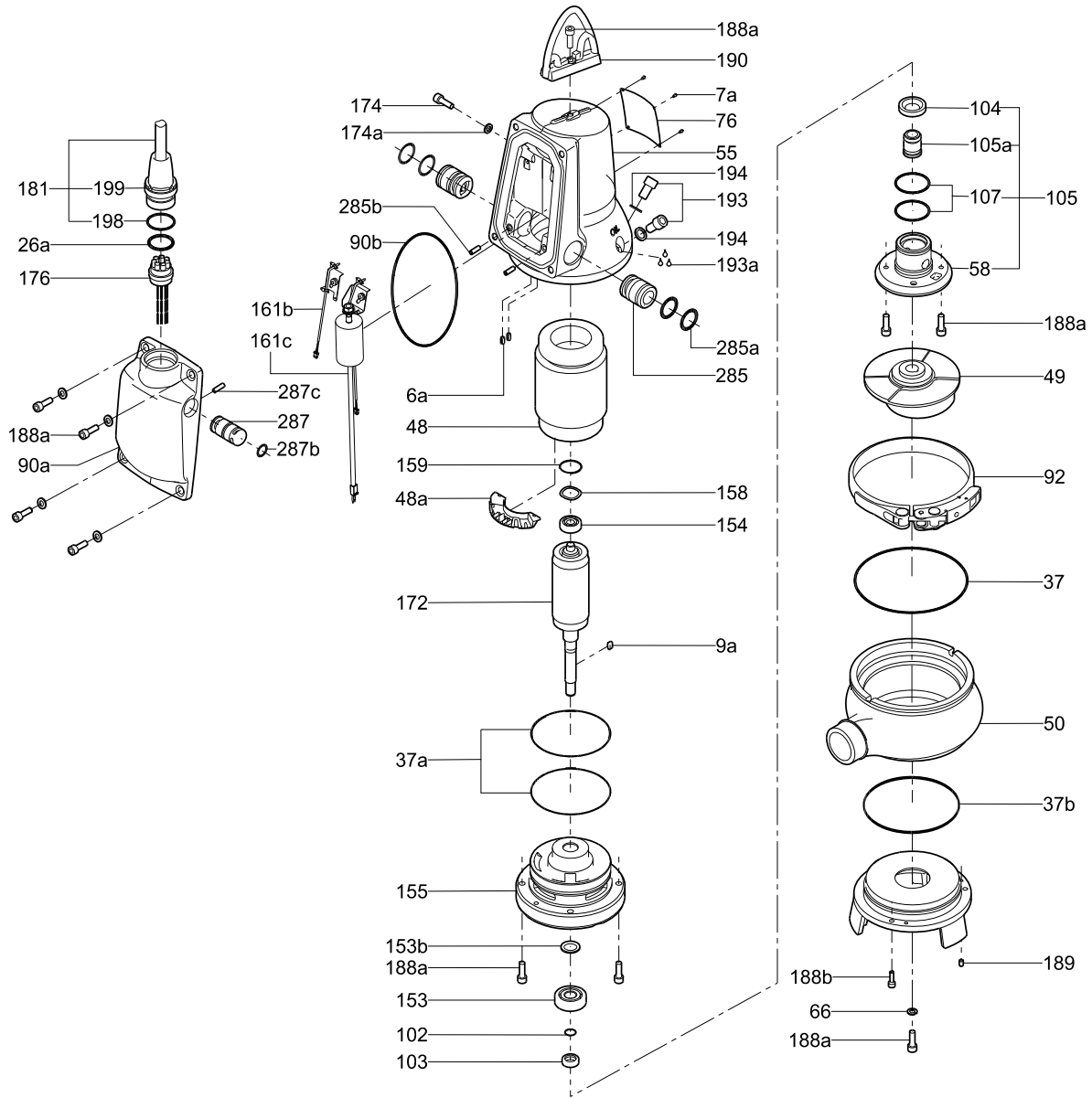

Fig. 16 Exploded view, EF AUTO_{ADAPT}

TM04 4870 2109

Material specification, SL1 and SLV pumps

The position numbers in the table below refer to the sectional drawings and exploded views on the following pages.

Pos.	Description	Material	EN standard	AISI/ASTM
6a	Pin	Stainless steel		
7a	Rivet	Stainless steel	1.4301	304
9a	Key	Stainless steel		
26a	O-ring	NBR		
37	O-ring	NBR		
37a	O-rings	NBR		
37b	O-rings	NBR		
48	Stator			
48a	Terminal board			
49	Impeller	Cast iron	EN-GJS-500-7	
50	Pump housing	Cast iron	EN-GJL-250	
55	Stator housing	Cast iron	EN-JL-1030	
58	Shaft seal carrier	Cast iron	EN-JL-1030	
66	Locking ring	Stainless steel		
76	Nameplate	Stainless steel	1.4301	304
92	Clamp	Stainless steel	1.4301	304
102	O-ring	NBR		
103	Bush	Stainless steel	1.4057	431
104	Seal ring	NBR		
105	Shaft seal			
105a	Shaft seal			
107	O-rings	NBR		
150a	Stator in housing complete			
153	Bearing	6204		
153b	Washer	Steel		
154	Bearing	6303		
155	Oil chamber	Cast iron		
158	Corrugated spring	Steel		
159	O-ring	NBR		
162	Wear plate*	Cast iron		
172	Rotor Shaft	Stainless steel	1.0533 1.4301	304
173	Screw	Steel		
173a	Washer	Steel		
176	Inner plug part	PET		
181	Outer plug part	CR rubber, cable H07RN-F	1.4308	
185	O-ring	NBR		
187	Screw	Steel		
188a	Screw	Stainless steel		CF-8
188b	Locking screw			
189	Adjusting screw			
190	Lifting bracket	Stainless steel	1.4308	
193	Oil screw	Stainless steel		CF-8
193a	Oil	Shell Ondina 917		
194	Gasket	Nylon		
198	O-ring	NBR		

* SL1 pumps only.

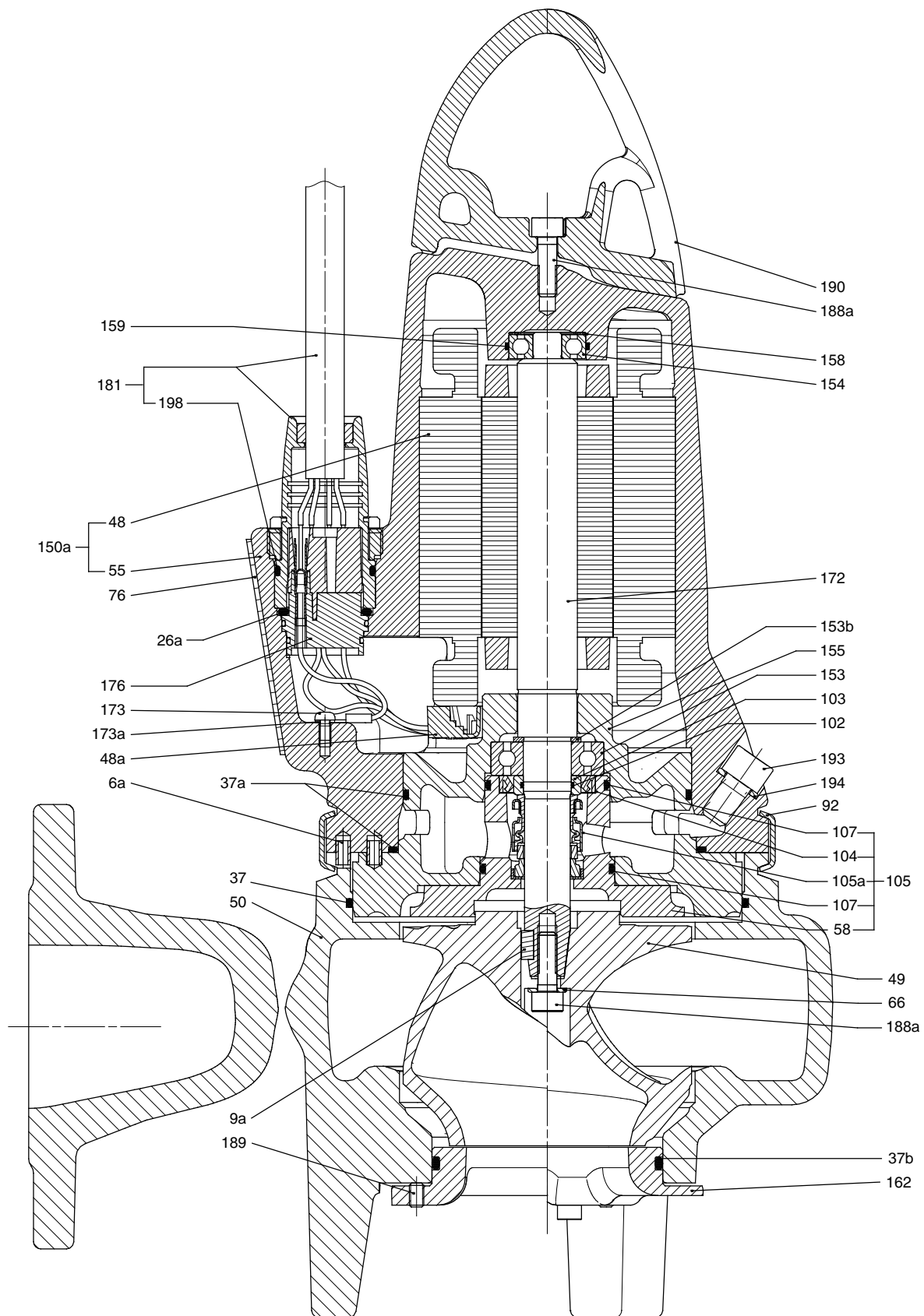

Fig. 17 Sectional drawing, SL1.50.65.09/11/15

TM02 7360 0904

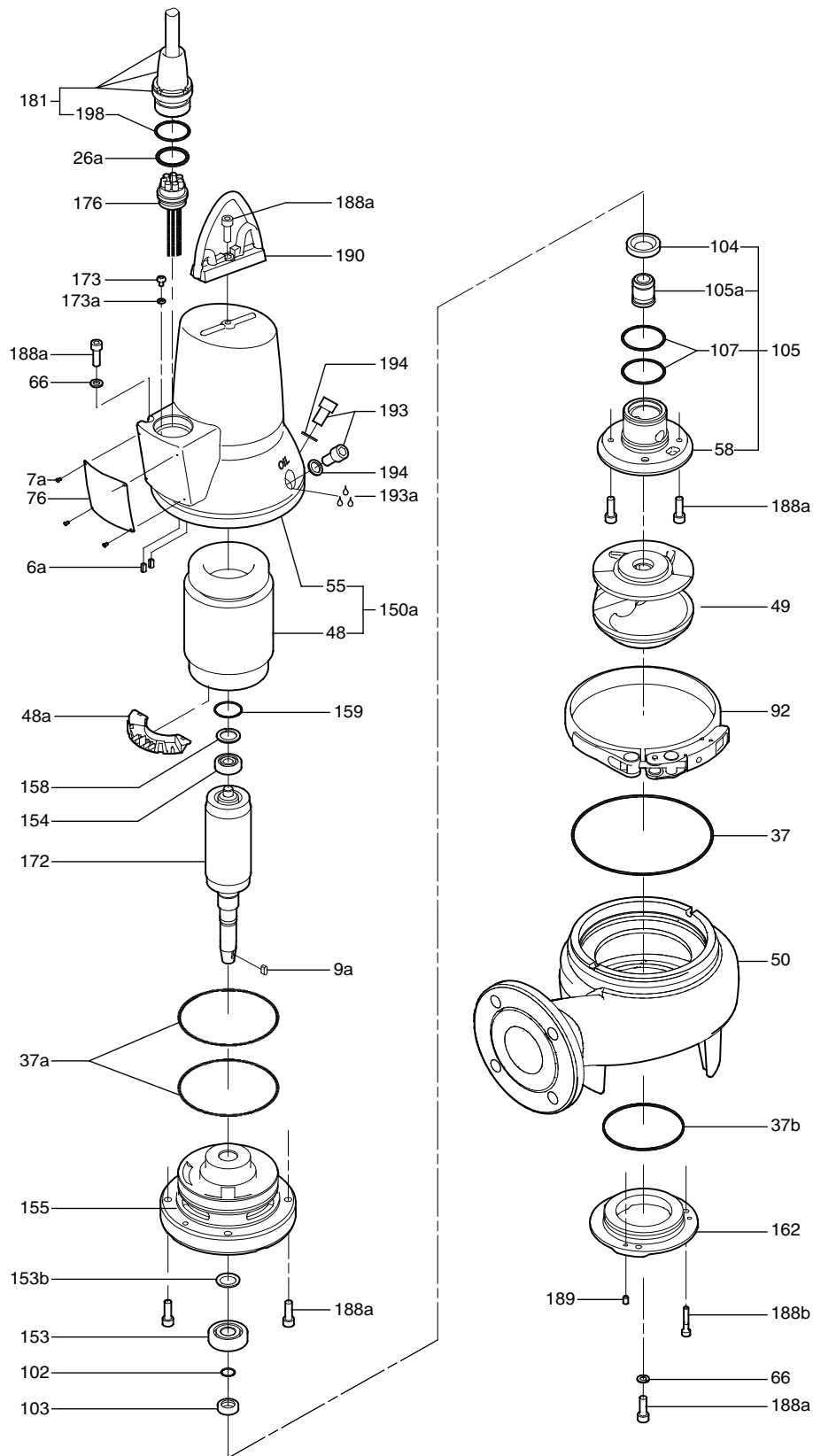

Fig. 18 Exploded view, SL1.50.65.09/11/15

TM02 7363 0904

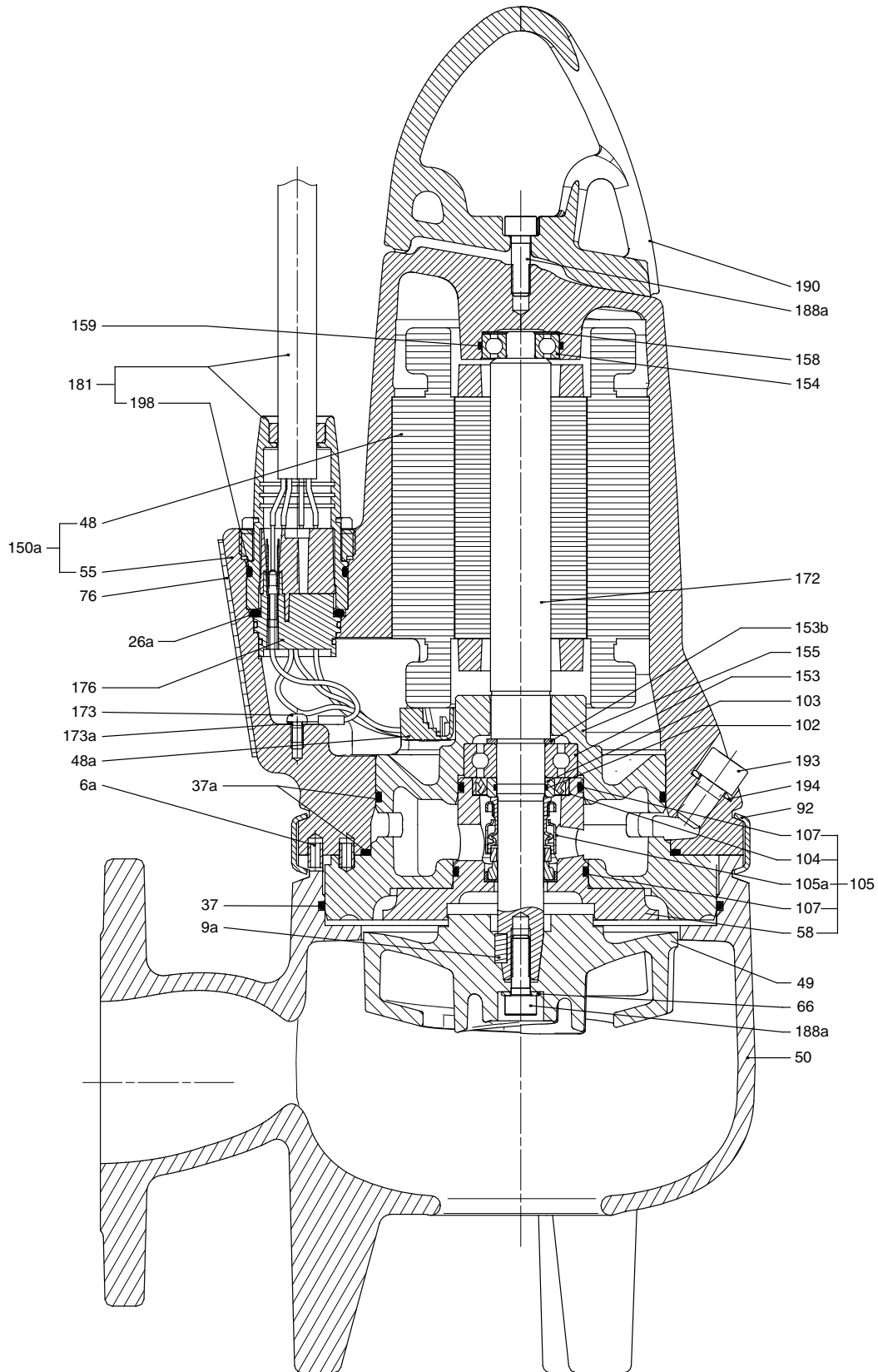

Fig. 19 Sectional drawing, SLV.65.65.09/11/15

TM02 7361 0904

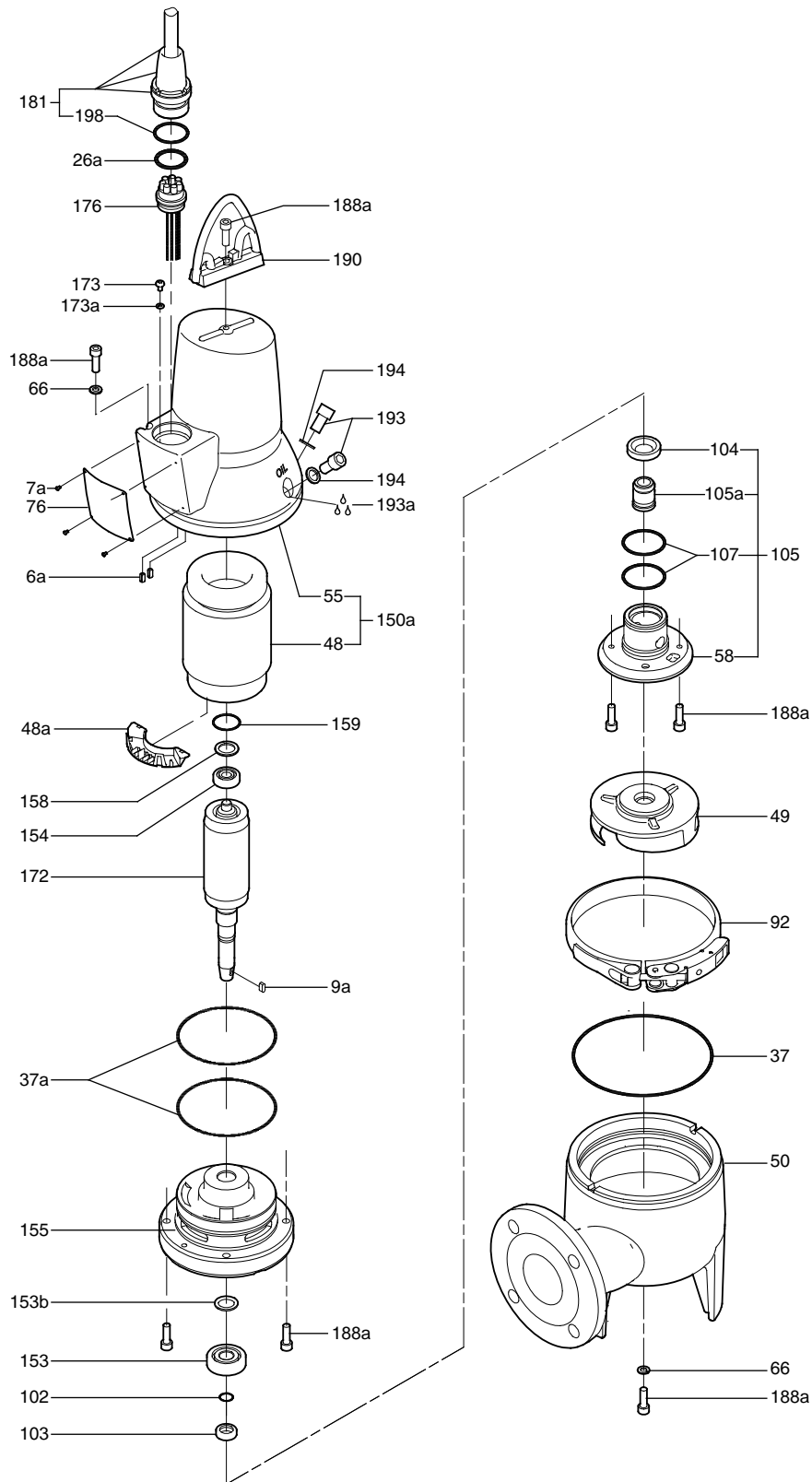

Fig. 20 Exploded view, SLV.65.65.09/11/15

TM02 7364 0904

Material specification, SL1 and SLV AUTO_{ADAPT} pumps

The position numbers in the table below refer to the sectional drawings and exploded views on the following pages.

Pos.	Description	Material	EN standard	AISI/ASTM
6a	Pin	Stainless steel		
7a	Rivet	Stainless steel		
9a	Key	Stainless steel		
26A	O-ring			
37	O-ring			
37a	O-rings	NBR		
37b	O-ring			
48	Stator			
48a	Terminal board			
49	Impeller	Cast iron	EN-JL-1030	
50	Pump housing	Cast iron	EN-JL-1030	
55	Stator housing	Cast iron	EN-JL-1030	
58	Shaft seal carrier	Cast iron	EN-JL-1030	
66	Locking ring	Stainless steel		
76	Nameplate	Stainless steel	1.4301	304
90a	Electronic unit			
90b	O-ring			
92	Clamp	Stainless steel	1.4301	304
102	O-ring	NBR		
103	Bush	Stainless steel	1.4057	431
104	Seal ring	NBR		
105/105a	Shaft seal	Primary seal (0.9 to 1.5 kW): SiC/SiC Secondary seal (0.9 to 1.5 kW): lip seal, NBR		
107	O-rings	NBR		
153	Bearing	Up to and including 1.5 kW: 6303		
154	Bearing	Up to and including 1.5 kW: 6201		
155	Oil chamber			
158	Corrugated spring	Steel		
159	O-ring	NBR		
161	Operating capacitor*			
161b	Nut			
161c	Bracket			
161d	Washer			
161e	Washer			
161f	Screw	Steel		
162	Wear plate***	Cast iron		
172	Rotor/shaft	Shaft part at rotor: steel Shaft end at hydraulics: stainless steel	1.0533 1.4301	304
173	Screw	Steel		
173a	Washer	Steel		
174	Earth screw			
174a	Washer			
176	Inner plug part	PET		
181	Outer plug part	CR rubber, cable H07RN-F	1.4308	CF-8
188a	Screw	Stainless steel		
188b	Locking screw	Steel		
190	Lifting bracket	Stainless steel	1.4308	CF-8
193	Oil screw	Stainless steel		
193a	Oil	Shell Ondina 913		
194	Gasket	Nylon		
198	O-ring	NBR		
285	Dry-running sensors**			
285a	O-ring	NBR	1.4308	CF-8
285b	Set screw			
287	Level sensor			
287a	Protection cap			

Pos.	Description	Material	EN standard	AISI/ASTM
287b	O-ring			
287c	Set screw			
288	Pt1000 sensor			
	Paint	Two-component epoxy		

* Single-phase pumps only.

** Explosion-proof pumps have two dry-running sensors.

*** SL1 pumps only.

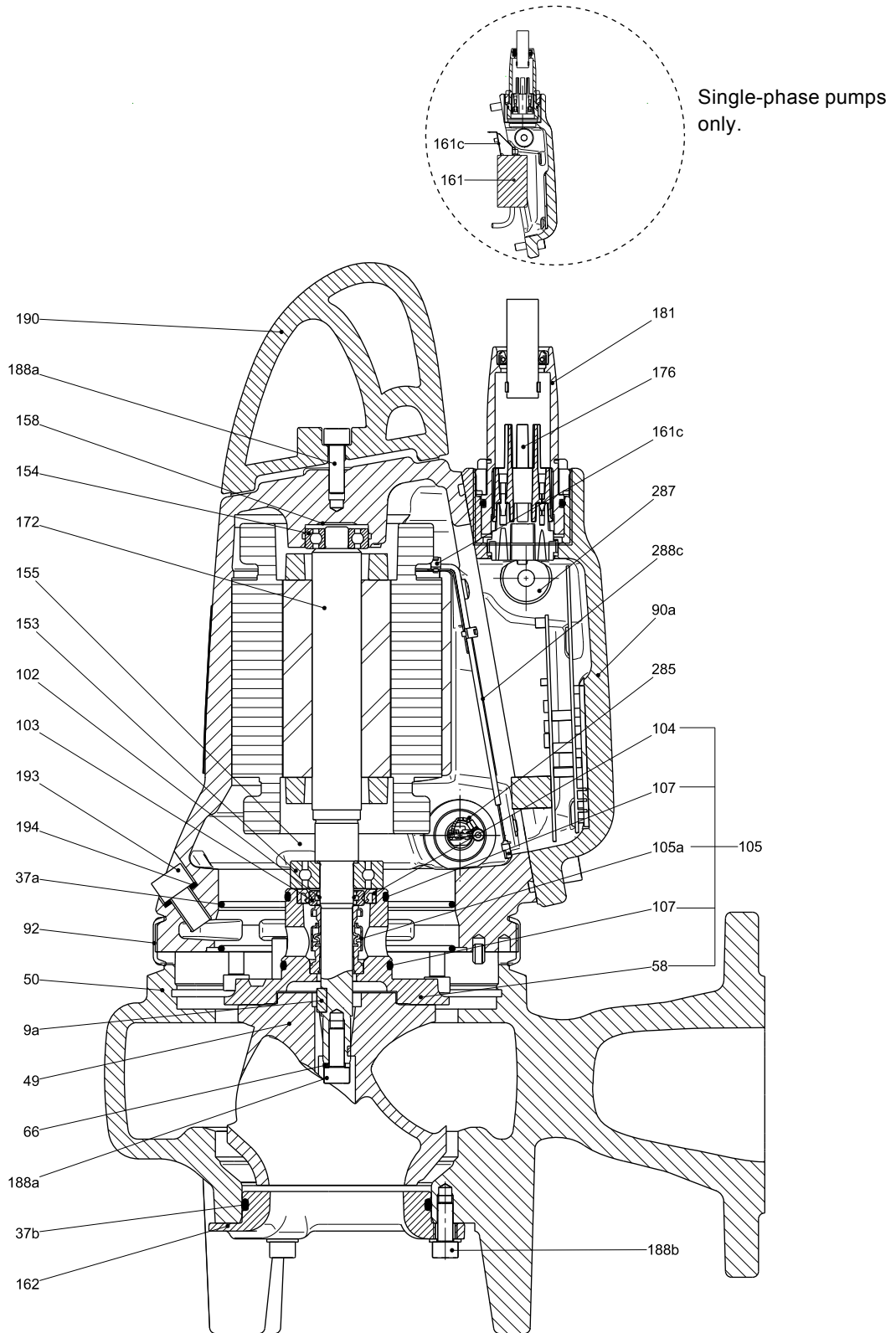
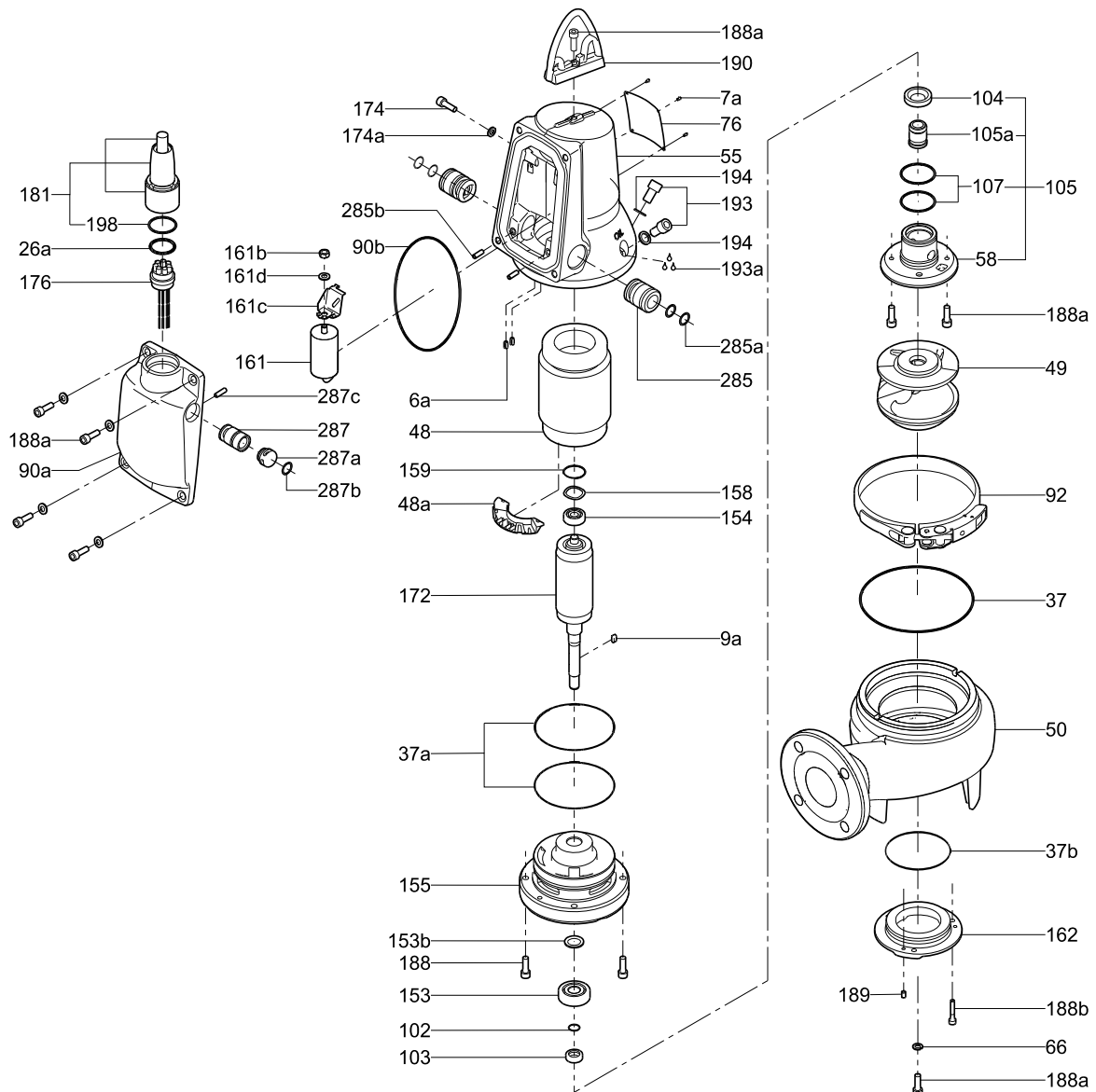

Fig. 21 Sectional drawing, SL1.50.65.09/11/15 AUTO_{ADAPT}

TM04 5992 4609



TM04 4799 2109

Fig. 22 Exploded view, SL1.50.65.09/11/15 AUTO_{ADAPT}

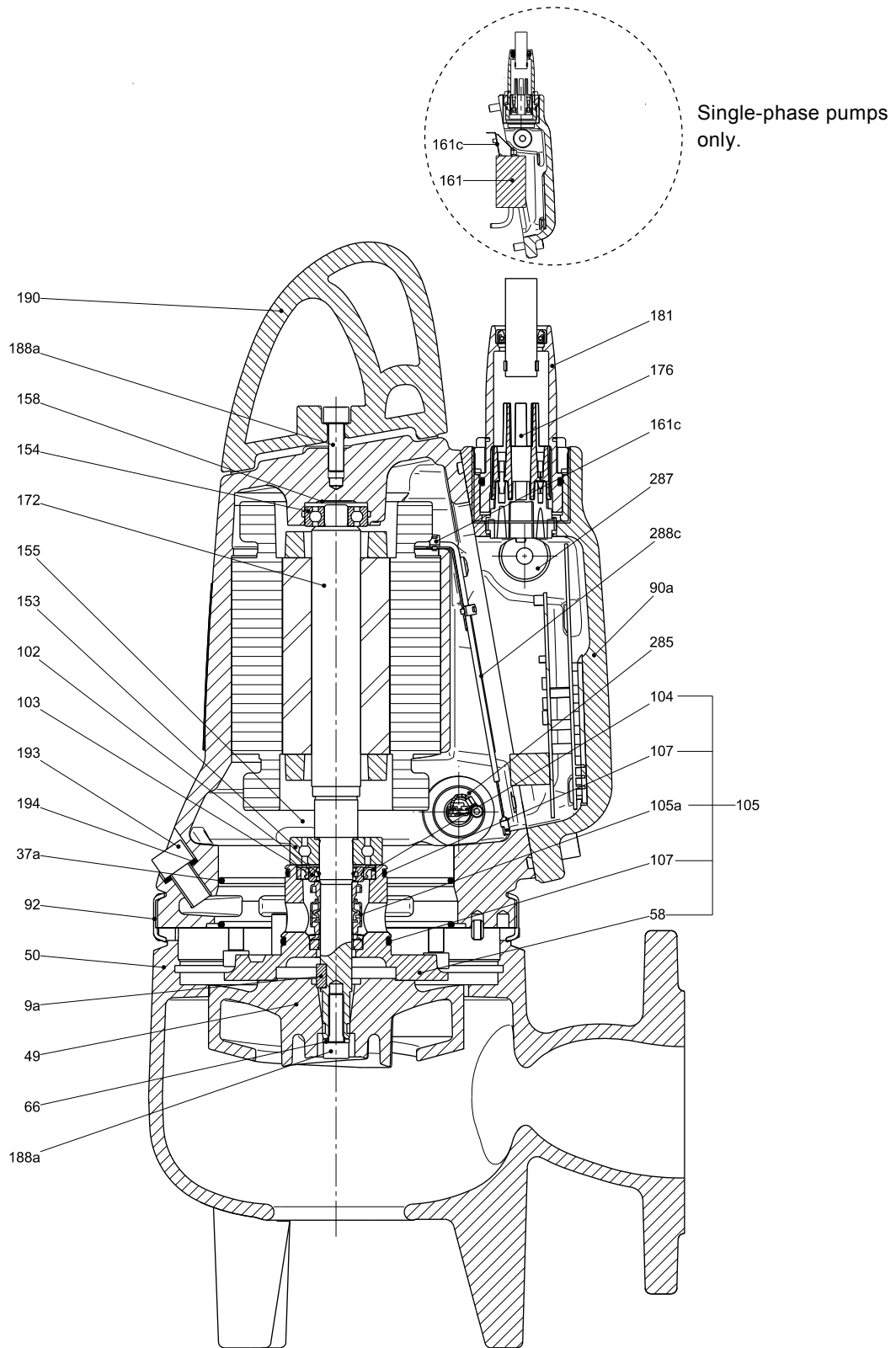

Fig. 23 Sectional drawing, SLV.65.65.09/11/15 AUTO_{ADAPT}

TM04 599Z 4609

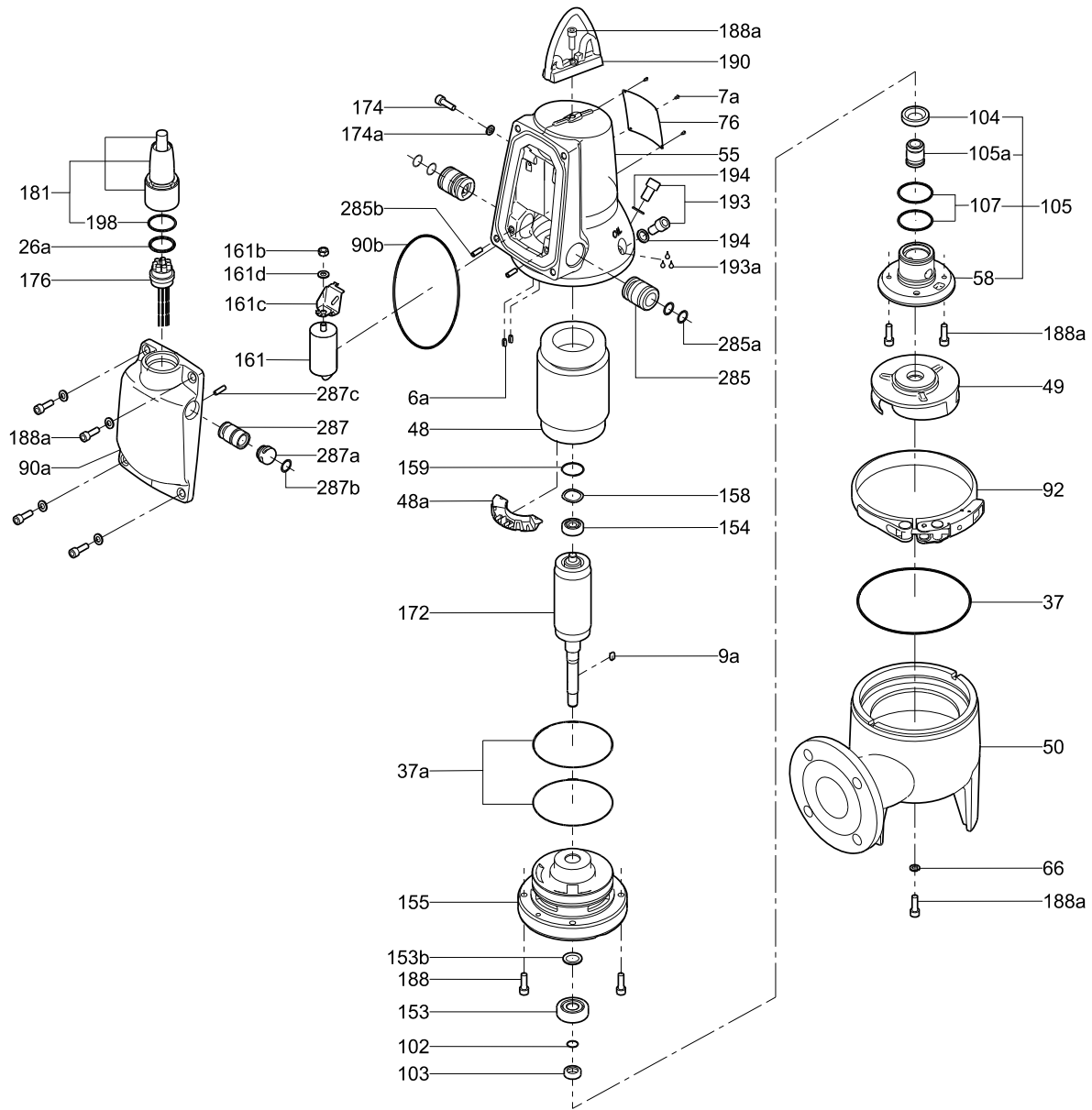

Fig. 24 Exploded view, SLV.65.65.09/11/15 AUTO_{ADAPT}

TM04 4800 2109

Features

Ball bearings

The ball bearings are greased for life.

Top bearings:

- Up to and including 1.5 kW:
Single-row ball bearing 6201.
- 2.6 kW and up:
Single-row ball bearing 6205.

Bottom bearings:

- Up to and including 1.5 kW:
Single-row ball bearing 6303.
- 2.6 kW and up:
Angular-contact ball bearing 3205.

Shaft seal

The DP, EF, SL1 and SLV pump ranges are available with two shaft seal variants. Both variants are fitted as cartridge seal units. The shaft seal separates the motor from the pumped liquid.

Pumps up to and including 1.5 kW have a silicon carbide/silicon carbide (SiC/SiC) mechanical shaft seal as primary seal and a lip seal as secondary seal. In connection with service, the mechanical shaft seal and the lip seal are supplied as one unit ready for fitting.

Pumps of 2.6 kW and up have a double seal consisting of a SiC/SiC mechanical shaft seal as primary seal and a carbon/aluminium oxide mechanical shaft seal as secondary seal.

Motor

The motor is a watertight, totally encapsulated motor.

Insulation class: F (155 °C).

Temperature class: F (105 °C).

Enclosure class: IP68.

For motor protection and sensors, see section *Sensors*.

Power supply cables

Standard cable

Cable type	Outer cable diameter [mm]	Bending radius	
		Fixed	Free
Lyniflex 4 G 1.5 mm ² + 3 x 1 mm ²	15.5 ± 0.5	60	90
Lyniflex 4 G 2.5 mm ² + 3 x 1 mm ²	17.0 ± 0.5	66	99
Lyniflex 7 G 2.5 mm ² + 3 x 1 mm ²	18.5 ± 0.5	74	111

EMC cable

Cable type	Outer cable diameter [mm]	Bending radius	
		Fixed	Free
3G3GC3G-F3x1AiC+4 G 2.5 mm ²	17.5 ± 0.5	85	170

As standard, the cables are 10 metres long. Other cable lengths are available on request. See section *List of variants*, page 20.

The number and dimension of cables depend on the motor size.

Cable entry

The stainless-steel plug is fastened with a union nut. The nut and O-rings provide sealing against ingress of the liquid.

The plug is filled with a special material that is cast into the plug around the leads of the cable. This prevents the ingress of water into the motor through the cable in case of cable breakage or adverse handling in connection with installation or service.

Sensors

DP, EF, SL1 and SLV pumps

As standard, the pumps have two thermal switches incorporated in the motor windings to protect the motor against overheating.

DP, EF, SL1 and SLV AUTO_{ADAPT} pumps

As standard, the pumps incorporate the following:

- One analog absolute-pressure transmitter.
- One dry-running sensor.
Explosion-proof versions have two dry-running sensors.
The dry-running sensor(s) are used for indicating the stop level in the first pump cycle and to prevent dry running.
On standard versions, the dry-running sensor can be overruled by an optional CIU unit if there is a risk of a floating layer.
- All pumps have two sets of thermal switches incorporated in the stator windings to protect the motor against overheating.
- Two Pt1000 sensors for analog measurement.
- Built-in motor protection I² (t) as extra safety.

Operating conditions

The pumps are designed for intermittent operation (S3). When completely submerged, the pumps can also operate continuously (S1).

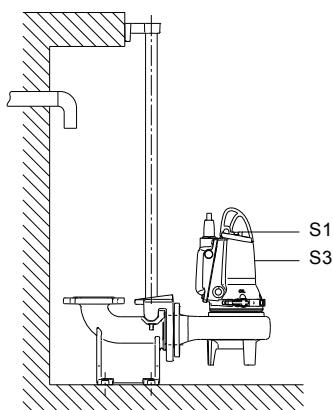

TM04 4810 2109

Fig. 25 Operation levels

- S3, intermittent operation:**
 The S3 operating mode means that within 10 minutes the pump must run for 4 minutes and be stopped for 6 minutes. See fig. 26. In this operating mode, the pump is partly submerged in the pumped liquid, i.e. the liquid level reaches at minimum the middle of the motor. See fig. 25.

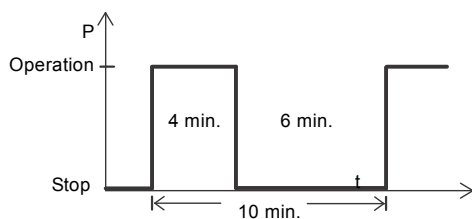

TM04 4527 1509

Fig. 26 S3 operation

- S1, continuous operation:**
 In this operating mode, the pump can operate continuously without having to be stopped for cooling. See fig. 27. Being completely submerged, the pump is sufficiently cooled by the surrounding liquid. See fig. 25.

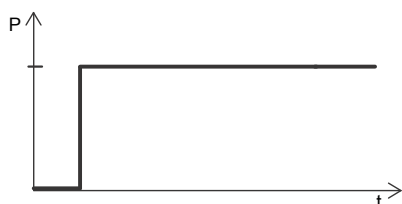

TM04 5228 1509

Fig. 27 S1 operation

Pumped liquids

pH value: 4 to 10.

Liquid temperature: 0 °C to +40 °C.

When pumping liquids with a density and/or a kinematic viscosity higher than that of water, use motors with correspondingly higher outputs.

For short periods (max. 3 minutes), temperatures up to 60 °C are permissible (non-Ex versions only).

Sound pressure level

The sound pressure level of the pump is lower than the limiting values stated in the EC Machinery Directive (2006/42/EC).

Motor range

Output power [kW]	Number of poles
0.6	2
0.9	2
1.1	2
1.5	2
2.6	2

Frequency converter operation

This section applies to DP, EF, SL1 and SLV pumps only.

Note: The DP, EF, SL1 and SLV AUTO_{ADAPT} pumps must not be used with a frequency converter.

In principle, all three-phase pumps, except the AUTO_{ADAPT} versions, can be connected to a frequency converter.

However, frequency converter operation will often expose the motor insulation system to a heavier load and cause the motor to be more noisy than usual due to eddy currents caused by voltage peaks.

In addition, large motors driven via a frequency converter will be loaded by bearing currents.

For more information, see the installation and operating instructions for the relevant frequency converter on www.grundfos.com (WebCAPS).

Approvals

DP, EF, SL1 and SLV standard and AUTO_{ADAPT} pumps have been tested by VDE.

The explosion-proof versions have been approved by KEMA according to the ATEX directive.

Approval standards

The standard versions are approved by LGA (notified body under the Construction Products Directive) according to EN 12050-1 and EN 12050-2.

Ex approval

The explosion protection classification of the pump is Europe CE 0344  II 2 G Ex b c d IIB T4 Gb.

Directive/standard	Code	Description
ATEX	CE 0344	= CE mark of conformity according to the ATEX directive 94/9/EC, Annex X. 0344 is the number of the notified body which has certified the quality system for ATEX.
		= Explosion protection mark.
	II	= Equipment group according to the ATEX directive, Annex II, point 2.2, defining the requirements applicable to the equipment in this group.
	2	= Equipment category according to the ATEX directive, Annex II, point 2.2, defining the requirements applicable to the equipment in this category.
	G	= Explosive atmospheres caused by gases, vapours or mists.
Harmonised European standard	Ex	= The equipment conforms to the harmonised European standard.
	b	Control of ignition sources according to EN 13463-6: 2005.
	c	Constructional safety according to EN 13463-5: 2003 and EN 13463-1: 2009.
	d	= Flame-proof enclosure according to EN 60079-1: 2007.
	II	= Suitable for use in explosive atmospheres (not mines).
	B	= Classification of gases according to EN 60079-0: 2006, Annex A. Gas group B includes gas group A.
	T4	= Maximum surface temperature is 135 °C according to EN 60079-0: 2006.
	Gb	Equipment protection level (IEC).
	X	= The equipment is subject to special conditions for safe use. The conditions are mentioned in the certificate and these installation and operating instructions.

IEC countries (Australia and others) Ex d IIB T4 Gb

Directive/standard	Code	Description
IEC 60079-0 and IEC 60079-1	Ex	= The equipment conforms to the harmonised European standard.
	d	= Flame-proof enclosure according to IEC 60079-1: 2007.
	II	= Suitable for use in explosive atmospheres (not mines).
	B	= Classification of gases according to IEC 60079-0: 2006, Annex A. Gas group B includes gas group A.
	T4	= Maximum surface temperature is 135 °C according to IEC 60079-0: 2006.
	IP68	= Enclosure class according to IEC 60529.
	X	The equipment is subject to special conditions for safe use. The conditions are mentioned in the certificate and the installation and operating instructions.

Wiring diagrams

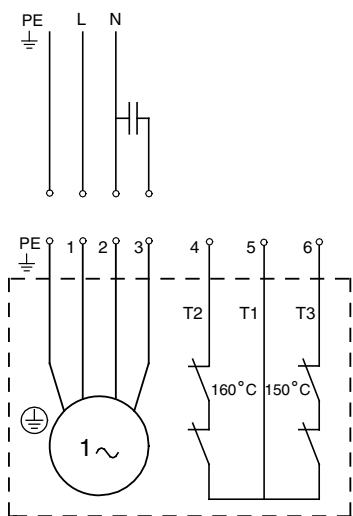

Fig. 28 Wiring diagram for single-phase pumps

TM02 5587 4302

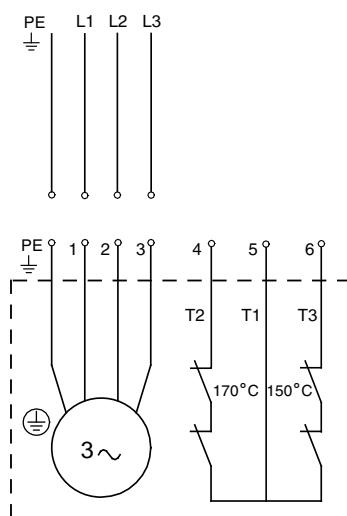

Fig. 30 Wiring diagram for three-phase pumps

TM02 5588 4302

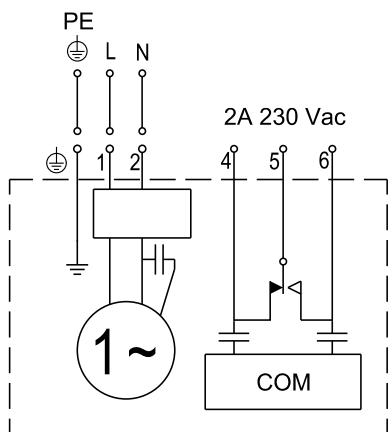

Fig. 29 Wiring diagram for single-phase AUTO_{ADAPT} pumps

TM04 4297 1209

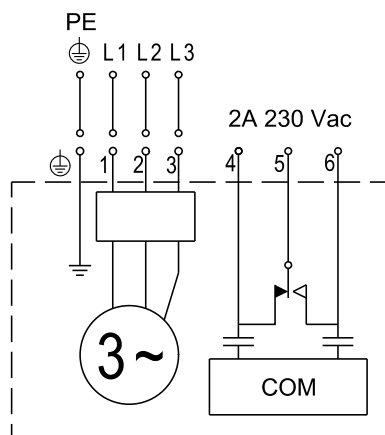

Fig. 31 Wiring diagram for three-phase AUTO_{ADAPT} pumps

TM04 4298 1209

How to read the performance curves

The curves on the following pages apply to DP, EF, SL1 and SLV standard and AUTO_{ADAPT} pumps as well as the explosion-proof versions.

Page	Pump curves	Page	Pump curves	Page	Pump curves	Page	Pump curves
54	Performance curves, DP10.50.09.(E).(Ex).1	58	Performance curves, EF30.50.06.(E).(Ex).1	65	Performance curves, SL1.50.65.09.(E).(Ex).1	70	Performance curves, SLV.65.65.09.(E).(Ex).1
55	Performance curves, DP10.50.09.(E).(Ex).3	59	Performance curves, EF30.50.06.(E).(Ex).3	66	Performance curves, SL1.50.65.09.(E).(Ex).3	71	Performance curves, SLV.65.65.09.(E).(Ex).3
56	Performance curves, DP10.50.15.(E).(Ex).3	60	Performance curves, EF30.50.09.(E).(Ex).1	67	Performance curves, SL1.50.65.11.(E).(Ex).1	72	Performance curves, SLV.65.65.11.(E).(Ex).1
57	DP10.65	61	Performance curves, EF30.50.09.(E).(Ex).3	68	Performance curves, SL1.50.65.11.(E).(Ex).3	76	Performance curves, SLV.65.65.11.(E).(Ex).3
		62	Performance curves, EF30.50.11.(E).(Ex).1	69	Performance curves, SL1.50.65.15.(E).(Ex).3	77	Performance curves, SLV.65.65.15.(E).(Ex).3
		63	Performance curves, EF30.50.11.(E).(Ex).3				
		64	Performance curves, EF30.50.15.(E).(Ex).3				

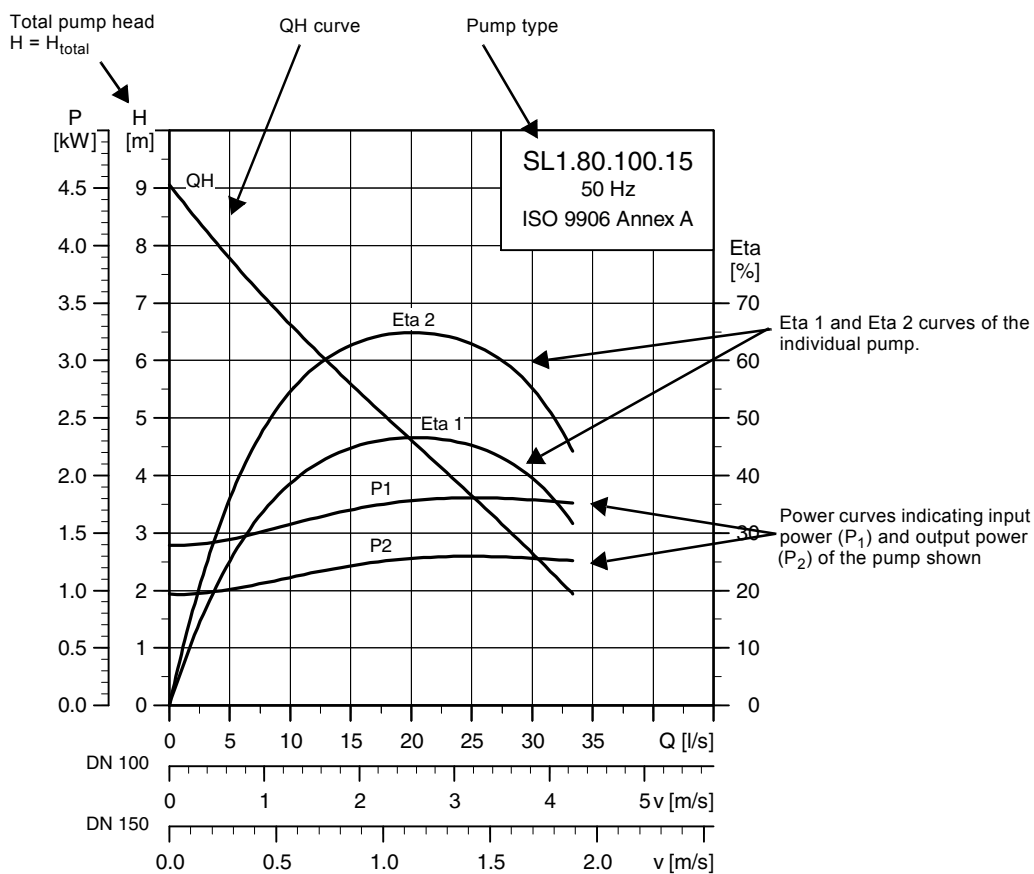

TM04 3460 4608

Curve conditions

The guidelines below apply to the curves on pages 54 to 77.

- Tolerances according to ISO 9906, Annex A.
 - The curves apply to the pumping of airless water at a temperature of +20 °C and a kinematic viscosity of 1 mm²/s (1 cSt).
 - The Eta curves show the efficiency of the pump.
 - Eta 1 is the overall efficiency of the pump (P_{hyd}/P_1).
 - Eta 2 is the hydraulic efficiency of the pump (P_{hyd}/P_2).
- P_2 : Pump input power.
 P_1 : Motor input power.
 P_{hyd} : Power applied by the pump to the liquid.
- In the case of other densities than 1000 kg/m³, the discharge pressure is proportional to the density.
 - When pumping liquids with a density higher than 1000 kg/m³, motors with correspondingly higher outputs must be used.

Calculation of total head

The total pump head consists of the height difference between the measuring points + the differential head + the dynamic head.

$$H_{\text{total}} = H_{\text{geo}} + H_{\text{stat}} + H_{\text{dyn}}$$

- H_{geo} : Height difference between measuring points.
 H_{stat} : Differential head across the pump.
 H_{dyn} : Calculated values based on the velocity of the pumped liquid on the suction and discharge sides of the pump.

Performance tests

The requested duty point of every pump is tested according to ISO 9906, Annex A, and without certification.

In the case of pumps ordered on the basis of impeller diameter only (no requested duty point), the pump will be tested at a duty point which is 2/3 of the maximum flow of the published performance curve which is related to the ordered impeller diameter (according to ISO 9906, Annex A).

If the customer requires either more points on the curve to be checked or certain minimum performances or certificates, individual measurements must be made, and a certificate can be ordered.

Certificates

Certificates have to be confirmed for every order and are available on request. See section *List of variants*, page 20.

Witness test

It is possible for the customer to witness the testing procedure according to ISO 9906.

The witness test is not a certificate and will not result in a written statement from Grundfos. The witness test itself is the only guarantee that everything is carried out as prescribed in the testing procedure.

If the customer wants to witness the test of the pump performance, this request must be stated on the order.

DP10.50

Performance curves, DP10.50.09.(E).(Ex).1

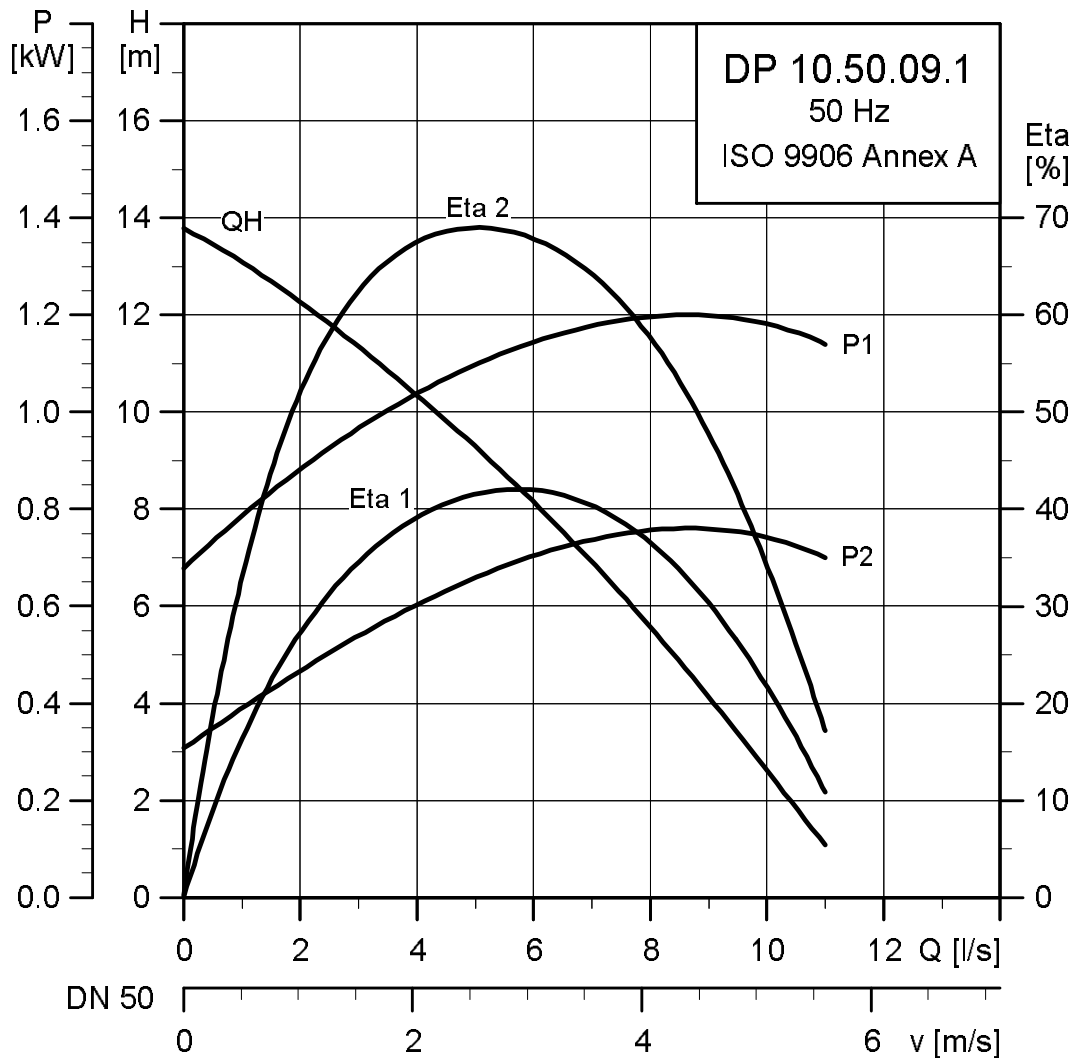

TM02 7463 1810

Electrical data

Voltage [V]	P1 [kW]	P2 [kW]	Number of poles	min ⁻¹	Starting method	Run capacitor [μF]	I _N		η _{motor} [%]				Cos φ		Moment of inertia [kgm ²]	Breakdown torque M _{max} [Nm]
							[A]	[A]	1/2	3/4	1/1	1/2	3/4	1/1		
1 x 230	1.3	0.9	2	2870	DOL	30	6.1	38	0.55	0.63	0.67	0.86	0.92	0.96	0.0033	7

Pump data

Impeller type	Max. solids size [mm]	Max. number of starts per hour	Max. installation depth [m]	Enclosure class	Insulation class	Max. liquid temperature [°C]	pH	Ex class
Semi-open	10	30	10	IP68	F	40	4-10	Ex d IIB T4/ Ex n IIB T4

Performance curves, DP10.50.09.(E).(Ex).3

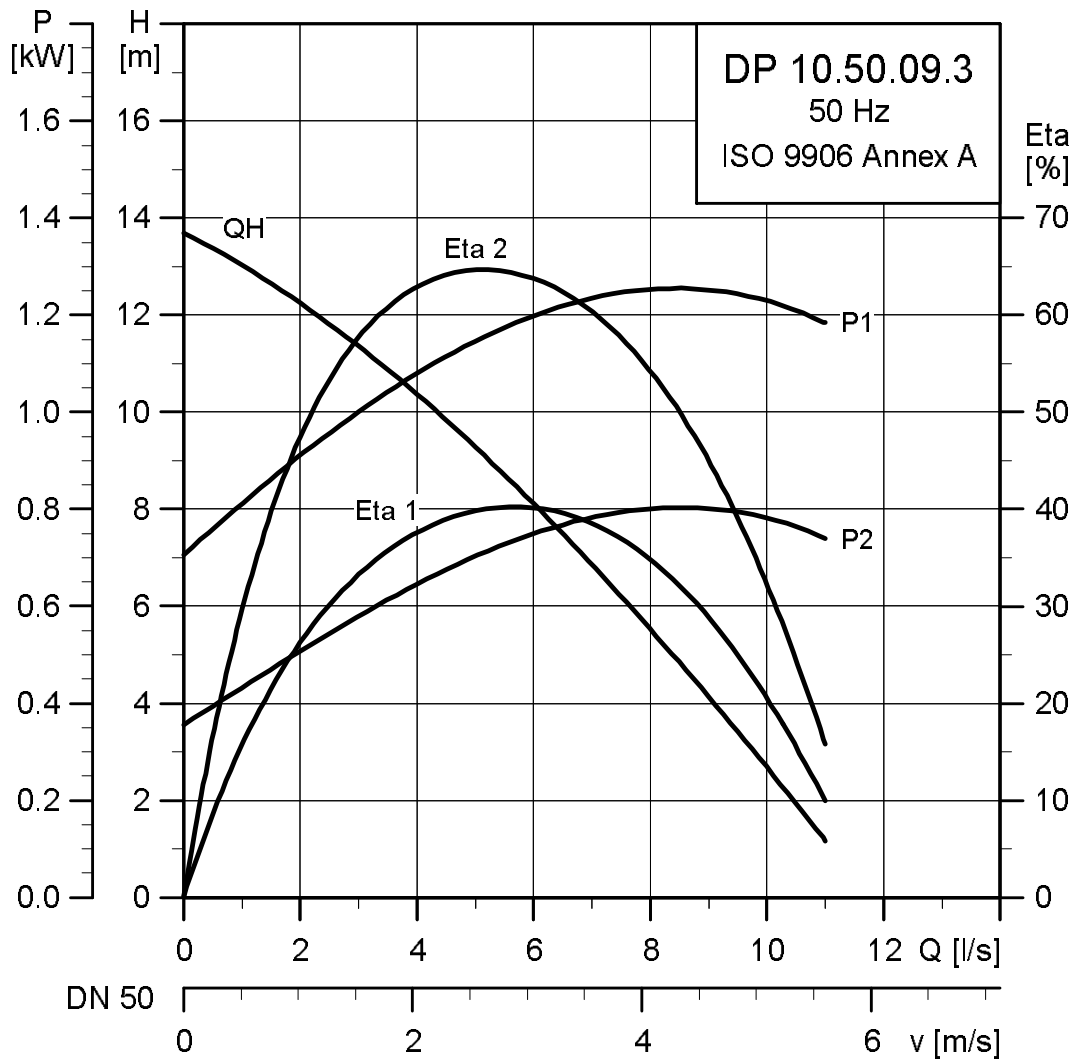

TM02 7462 1810

Electrical data

Voltage [V]	P1 [kW]	P2 [kW]	Number of poles	min ⁻¹	Starting method	I _N		η _{motor} [%]			Cos φ		Moment of inertia [kgm ²]	Breakdown torque M _{max.} [Nm]	
						[A]	[A]	1/2	3/4	1/1	1/2	3/4			1/1
3 x 400-415	1.38	0.9	2	2870	DOL	2.8	21	58	61	65	0.58	0.68	0.76	0.0033	12

Pump data

Impeller type	Max. solids size [mm]	Max. number of starts per hour	Max. installation depth [m]	Enclosure class	Insulation class	Max. liquid temperature [°C]	pH	Ex class
Semi-open	10	30	10	IP68	F	40	4-10	Ex d IIB T4/ Ex n IIB T4

Performance curves, DP10.50.15.(E).(Ex).3

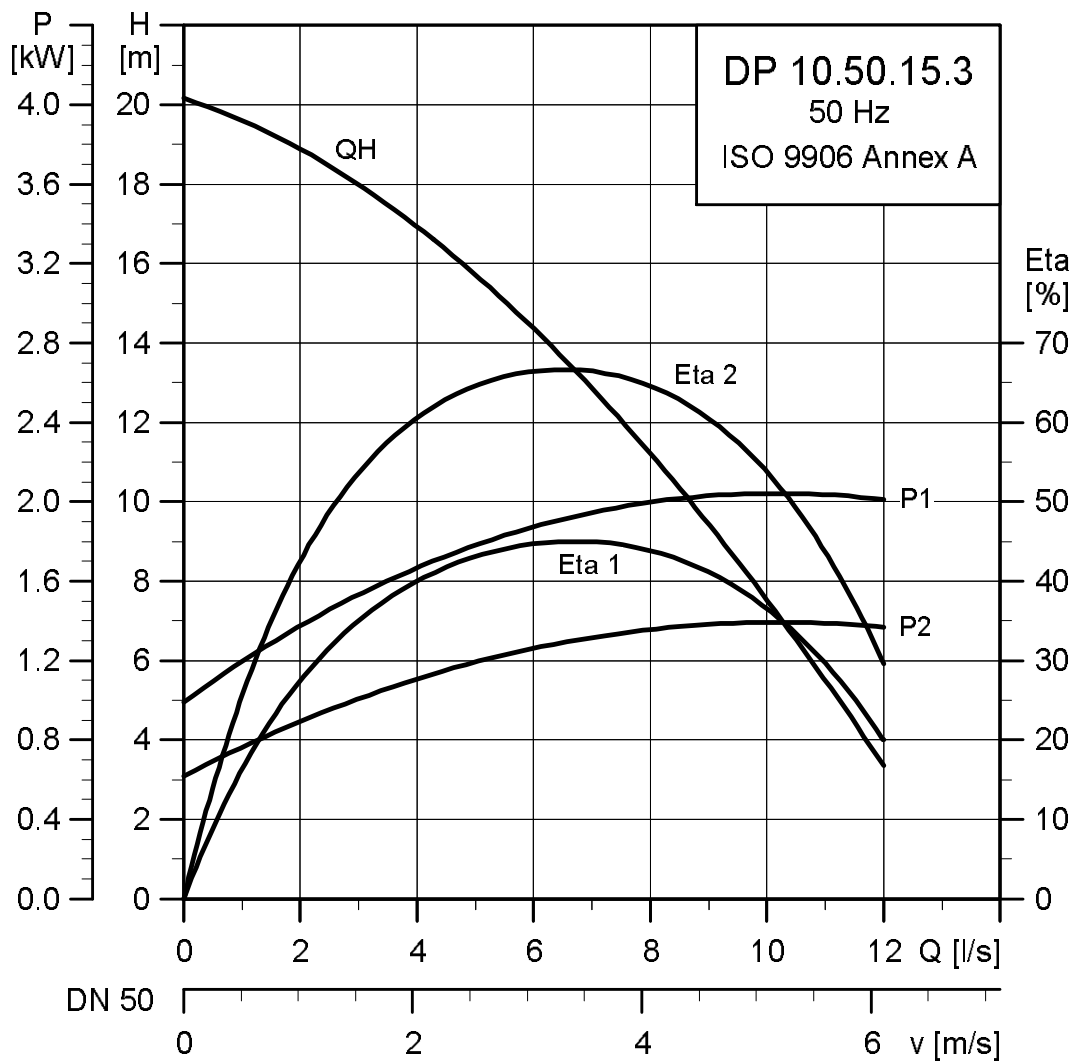

TM02 7461 1810

Electrical data

Voltage [V]	P1 [kW]	P2 [kW]	Number of poles	min ⁻¹	Starting method	I _N			I _{start}			η _{motor} [%]			Cos φ			Moment of inertia [kgm ²]	Breakdown torque M _{max.} [Nm]
						[A]	[A]	[A]	1/2	3/4	1/1	1/2	3/4	1/1	1/2	3/4	1/1		
3 x 400-415	2.2	1.5	2	2720	DOL	3.8	21		63	68	67	0.71	0.81	0.88	0.0036	12			

Pump data

Impeller type	Max. solids size [mm]	Max. number of starts per hour	Max. installation depth [m]	Enclosure class	Insulation class	Max. liquid temperature [°C]	pH	Ex class
Semi-open	10	30	10	IP68	F	40	4-10	Ex d IIB T4/ Ex n IIB T4

DP10.65

Performance curves, DP10.65.26.(E).(Ex).3

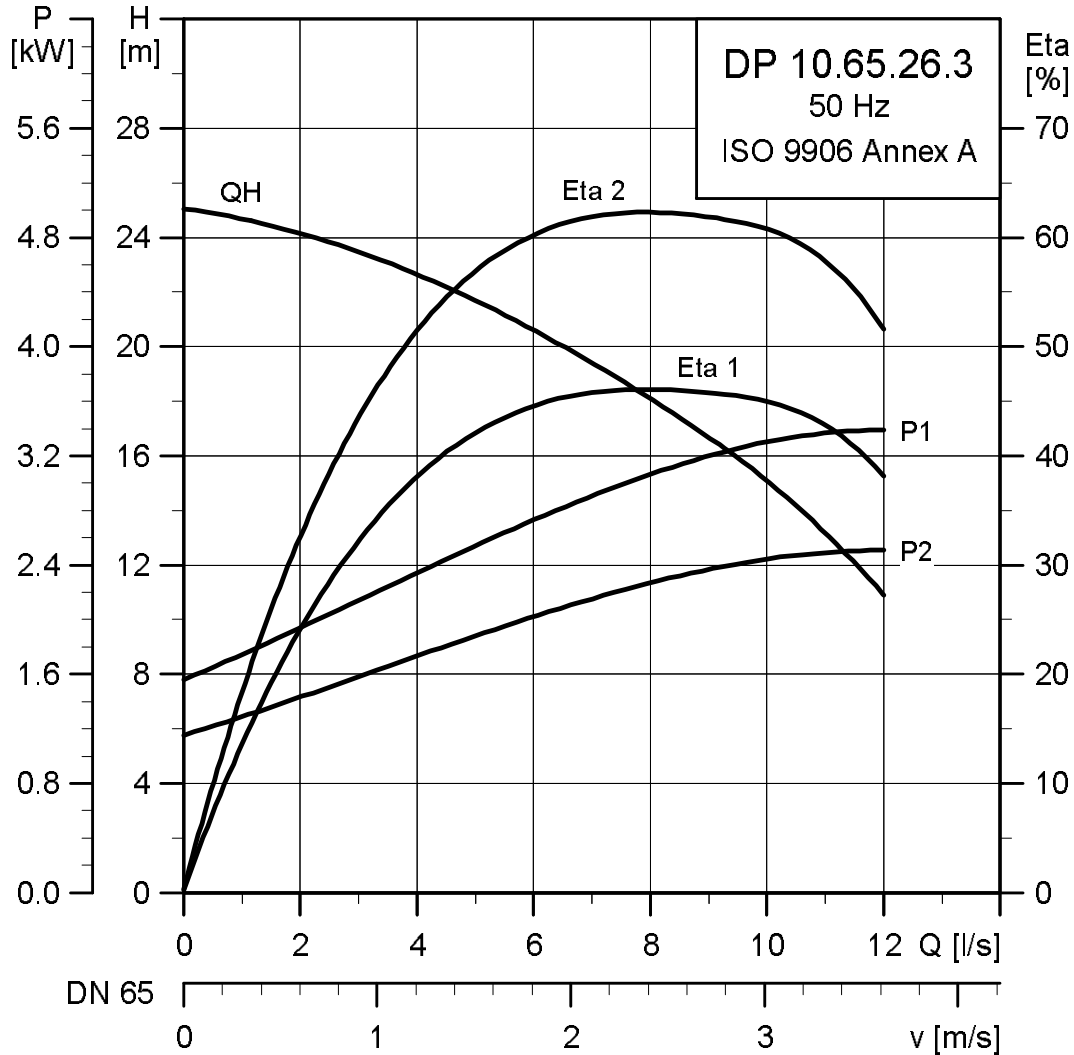

TM02 7464 1810

Electrical data

Voltage [V]	P1 [kW]	P2 [kW]	Number of poles	min ⁻¹	Starting method	I _N			I _{start}			η _{motor} [%]			Cos φ			Moment of inertia [kgm ²]	Breakdown torque M _{max.} [Nm]
						[A]	[A]	[A]	1/2	3/4	1/1	1/2	3/4	1/1	1/2	3/4	1/1		
3 x 400-415	3.5	2.6	2	2870	DOL	5.8	33	74	74	74	74	0.68	0.81	0.87	0.007	24			

Pump data

Impeller type	Max. solids size [mm]	Max. number of starts per hour	Max. installation depth [m]	Enclosure class	Insulation class	Max. liquid temperature [°C]	pH	Ex class
Semi-open	10	30	10	IP68	F	40	4-10	Ex d IIB T4/ Ex n IIB T4

EF30.50

Performance curves, EF30.50.06.(E).(Ex).1

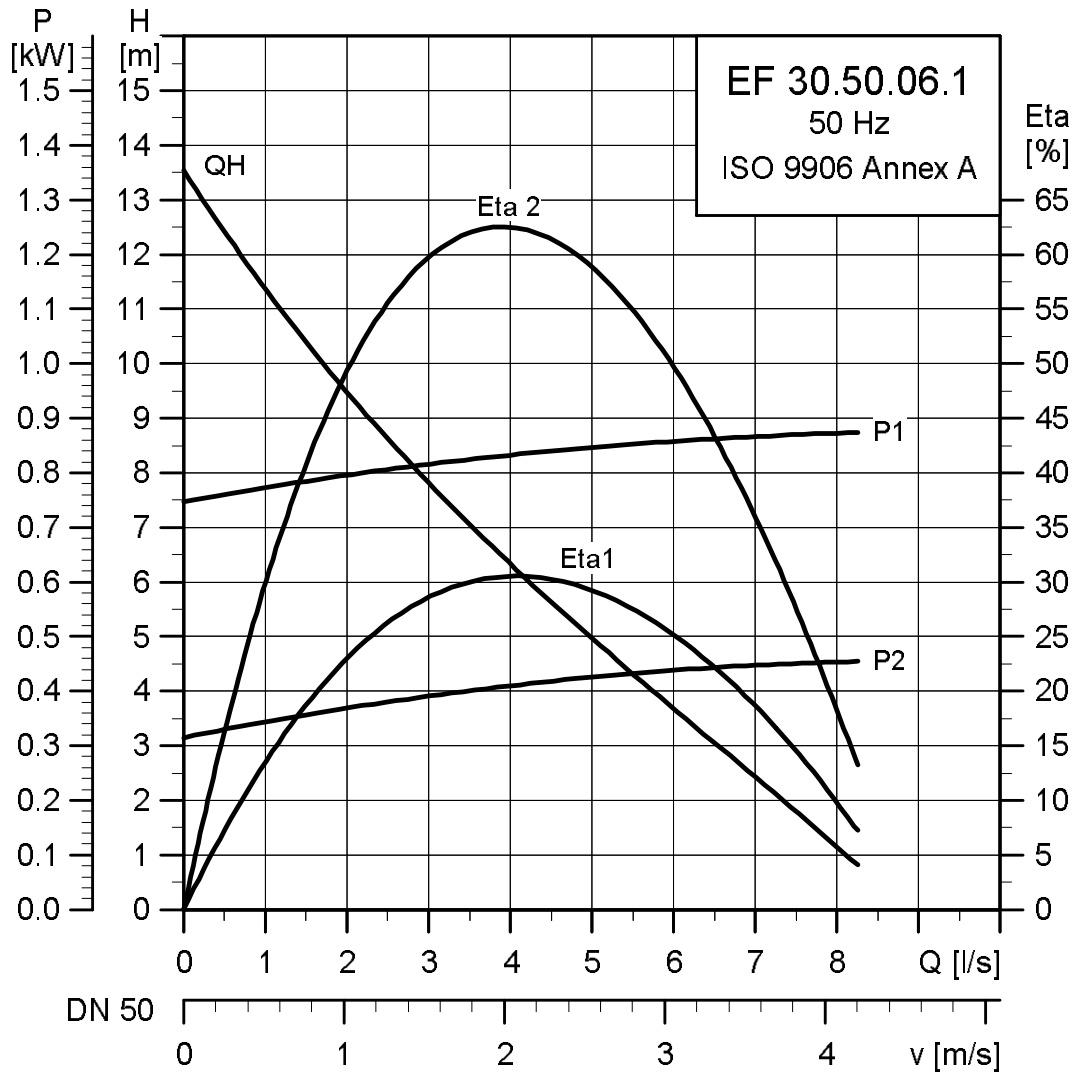

TM02 7469 1810

Electrical data

Voltage [V]	P1 [kW]	P2 [kW]	Number of poles	Max. speed min ⁻¹	Starting method	Run capacitor [μF]	I _N		I _{start}			η _{motor} [%]			Cos φ			Moment of inertia [kgm ²]	Breakdown torque M _{max.} [Nm]
							[A]	[A]	1/2	3/4	1/1	1/2	3/4	1/1	1/2	3/4	1/1		
1 x 230	0.98	0.6	2	2920	DOL	30	4.8	21	42	55	61	0.81	0.81	0.86	0.0035	7			

Pump data

Impeller type	Max. solids size [mm]	Max. number of starts per hour	Max. installation depth [m]	Enclosure class	Insulation class	Max. liquid temperature [°C]	pH	Ex class
Semi-open	30	30	10	IP68	F	40	4-10	Ex d IIB T4/ Ex n IIB T4

Performance curves, EF30.50.06.(E).(Ex).3

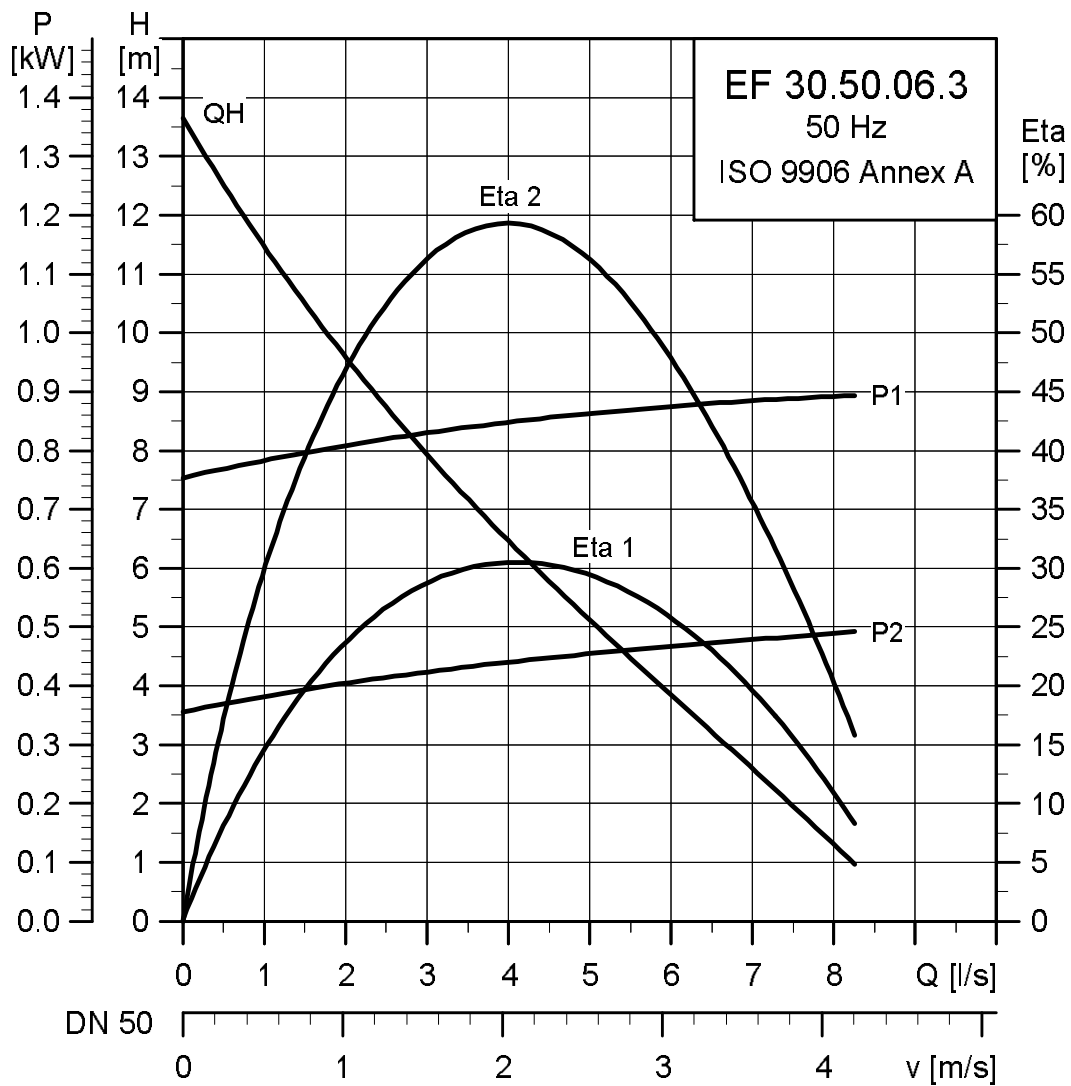

TM02 7468 1810

Electrical data

Voltage [V]	P1 [kW]	P2 [kW]	Number of poles	min ⁻¹	Starting method	I _N			η _{motor} [%]			Cos φ			Moment of inertia [kgm ²]	Breakdown torque M _{max} [Nm]
						I _{start} [A]	I _{1/2} [A]	I _{3/4} [A]	1/2	3/4	1/1	1/2	3/4	1/1		
3 x 400-415	1.0	0.6	2	2890	DOL	2.3	21	43	53	59	0.5	0.58	0.65	0.0035	12	

Pump data

Impeller type	Max. solids size [mm]	Max. number of starts per hour	Max. installation depth [m]	Enclosure class	Insulation class	Max. liquid temperature [°C]	pH	Ex class
Semi-open	30	30	10	IP68	F	40	4-10	Ex d IIB T4/ Ex n IIB T4

Performance curves, EF30.50.09.(E).(Ex).1

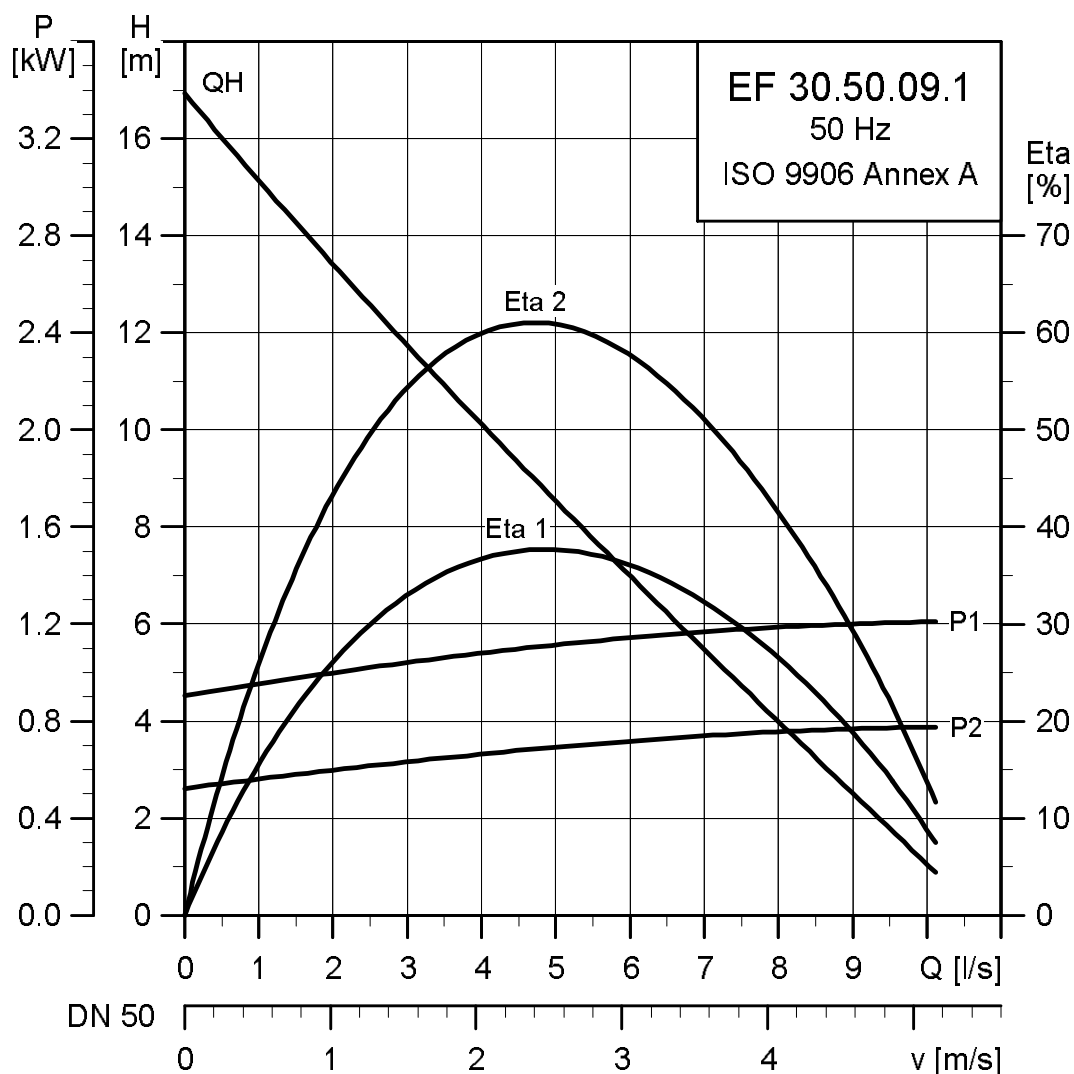

Electrical data

Voltage [V]	P1 [kW]	P2 [kW]	Number of poles	min ⁻¹	Starting method	Run capacitor [μF]	I _N		η _{motor} [%]			Cos φ			Moment of inertia [kgm ²]	Breakdown torque M _{max.} [Nm]
							[A]	[A]	1/2	3/4	1/1	1/2	3/4	1/1		
1 x 230	0.98	0.9	2	2920	DOL	30	4.8	21	42	55	61	0.81	0.81	0.86	0.0035	7

Pump data

Impeller type	Max. solids size [mm]	Max. number of starts per hour	Max. installation depth [m]	Enclosure class	Insulation class	Max. liquid temperature [°C]	pH	Ex class
Semi-open	30	30	10	IP68	F	40	4-10	Ex d IIB T4/ Ex n IIB T4

Performance curves, EF30.50.09.(E).(Ex).3

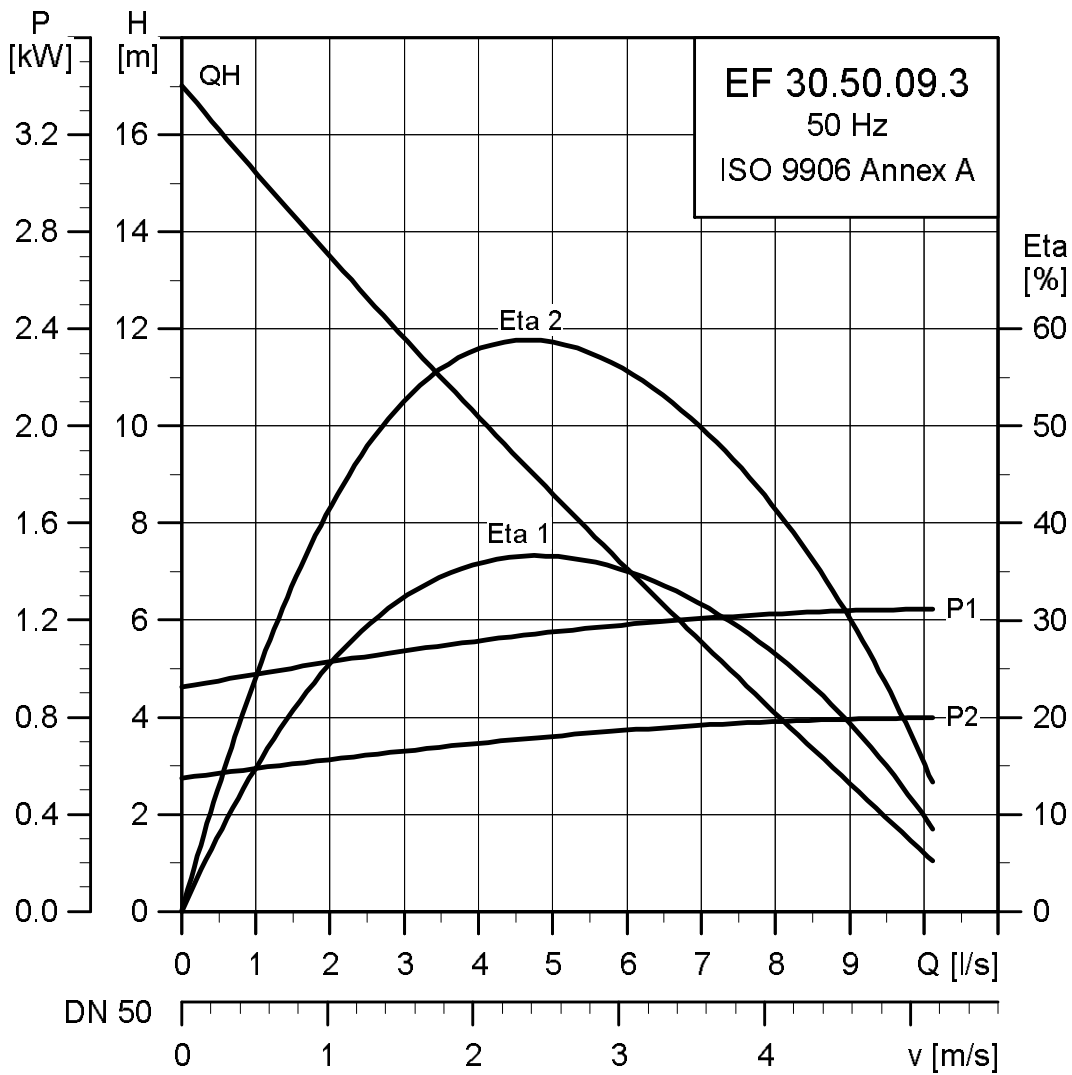

TM02 7480 1810

Electrical data

Voltage [V]	P1 [kW]	P2 [kW]	Number of poles	min ⁻¹	Starting method	I _N		η _{motor} [%]			Cos φ			Moment of inertia [kgm ²]	Breakdown torque M _{max} [Nm]
						[A]	[A]	1/2	3/4	1/1	1/2	3/4	1/1		
3 x 400-415	1.4	0.9	2	2870	DOL	2.8	21	58	61	65	0.58	0.68	0.76	0.0037	12

Pump data

Impeller type	Max. solids size [mm]	Max. number of starts per hour	Max. installation depth [m]	Enclosure class	Insulation class	Max. liquid temperature [°C]	pH	Ex class
Semi-open	30	30	10	IP68	F	40	4-10	Ex d IIB T4/ Ex n IIB T4

Performance curves, EF30.50.11.(E).(Ex).1

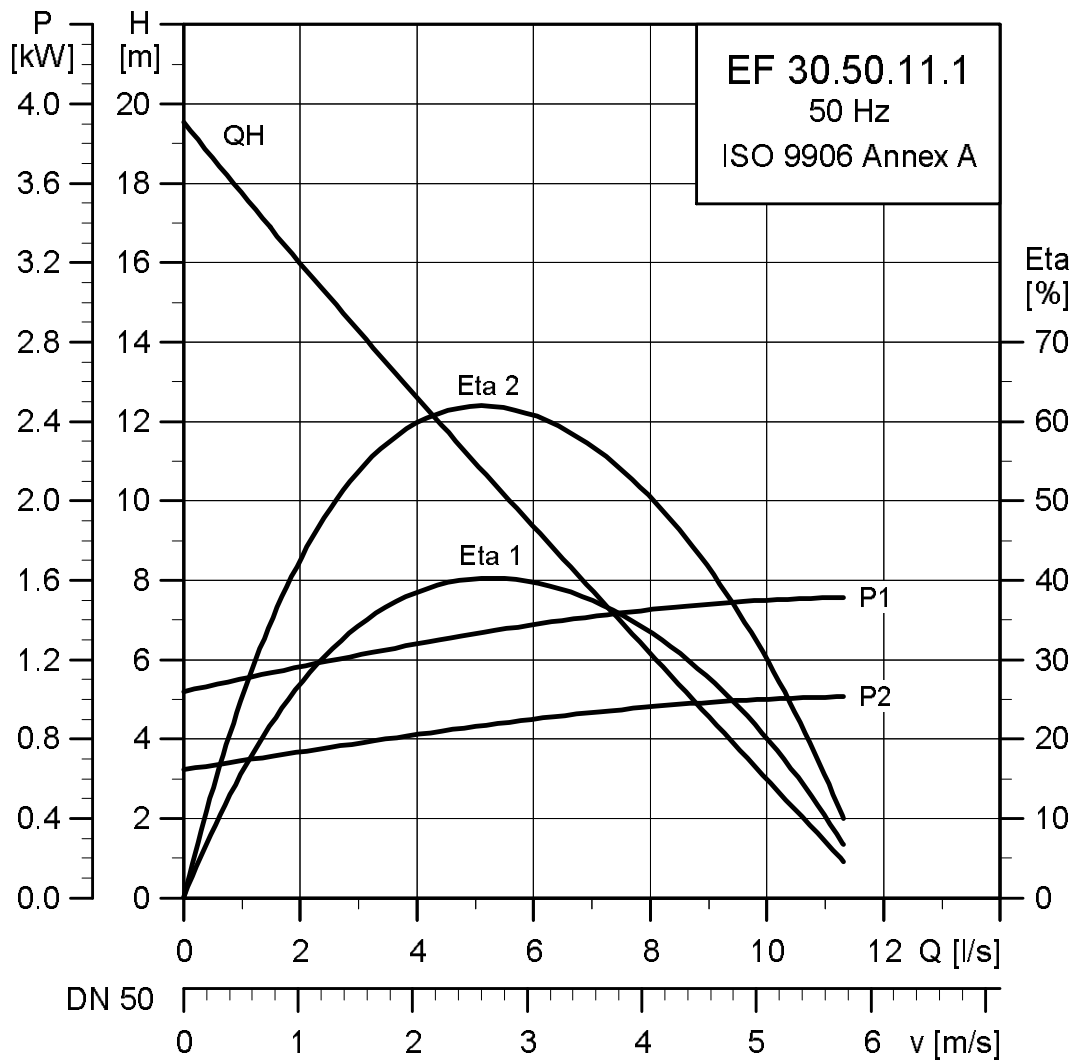

TM02 7467 1810

Electrical data

Voltage [V]	P1 [kW]	P2 [kW]	Number of poles	min ⁻¹	Starting method	Run capacitor [μF]	I _N		I _{start}			η _{motor} [%]			Cos φ			Moment of inertia [kgm ²]	Breakdown torque M _{max.} [Nm]
							[A]	[A]	1/2	3/4	1/1	1/2	3/4	1/1					
1 x 230	1.6	1.1	2	2830	DOL	30	7.4	38	60	66	67	0.89	0.96	0.97	0.0037	7			

Pump data

Impeller type	Max. solids size [mm]	Max. number of starts per hour	Max. installation depth [m]	Enclosure class	Insulation class	Max. liquid temperature [°C]	pH	Ex class
Semi-open	30	30	10	IP68	F	40	4-10	Ex d IIB T4/ Ex n IIB T4

Performance curves, EF30.50.11.(E).(Ex).3

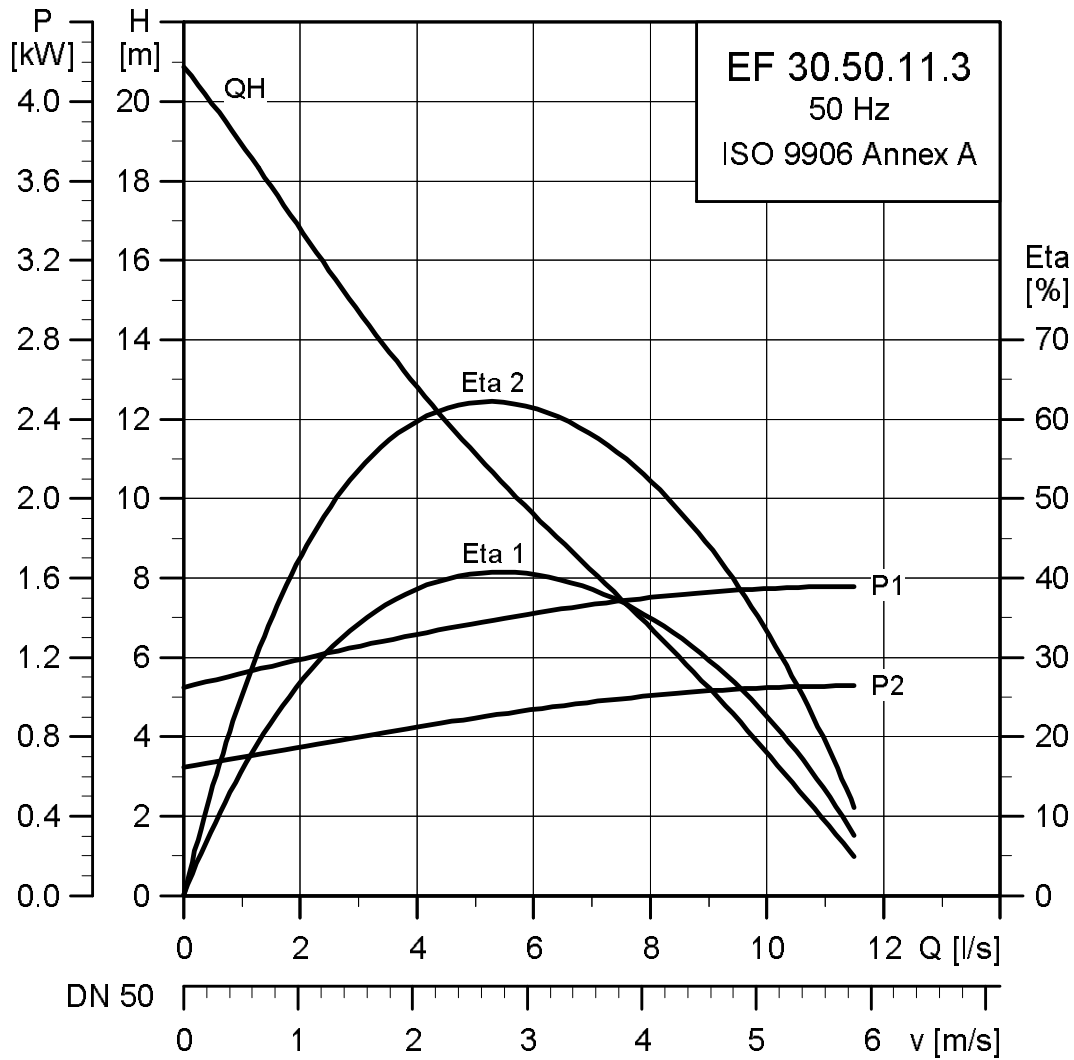

TM02 7466 1810

Electrical data

Voltage [V]	P1 [kW]	P2 [kW]	Number of poles	min ⁻¹	Starting method	I _N			I _{start}			η _{motor} [%]			Cos φ			Moment of inertia [kgm ²]	Breakdown torque M _{max.} [Nm]
						[A]	[A]	[A]	1/2	3/4	1/1	1/2	3/4	1/1	1/2	3/4	1/1		
3 x 400-415	1.6	1.1	2	2830	DOL	3.1	21		57	64	67	0.63	0.74	0.81	0.0037	12			

Pump data

Impeller type	Max. solids size [mm]	Max. number of starts per hour	Max. installation depth [m]	Enclosure class	Insulation class	Max. liquid temperature [°C]	pH	Ex class
Semi-open	30	30	10	IP68	F	40	4-10	Ex d IIB T4/ Ex n IIB T4

Performance curves, EF30.50.15.(E).(Ex).3

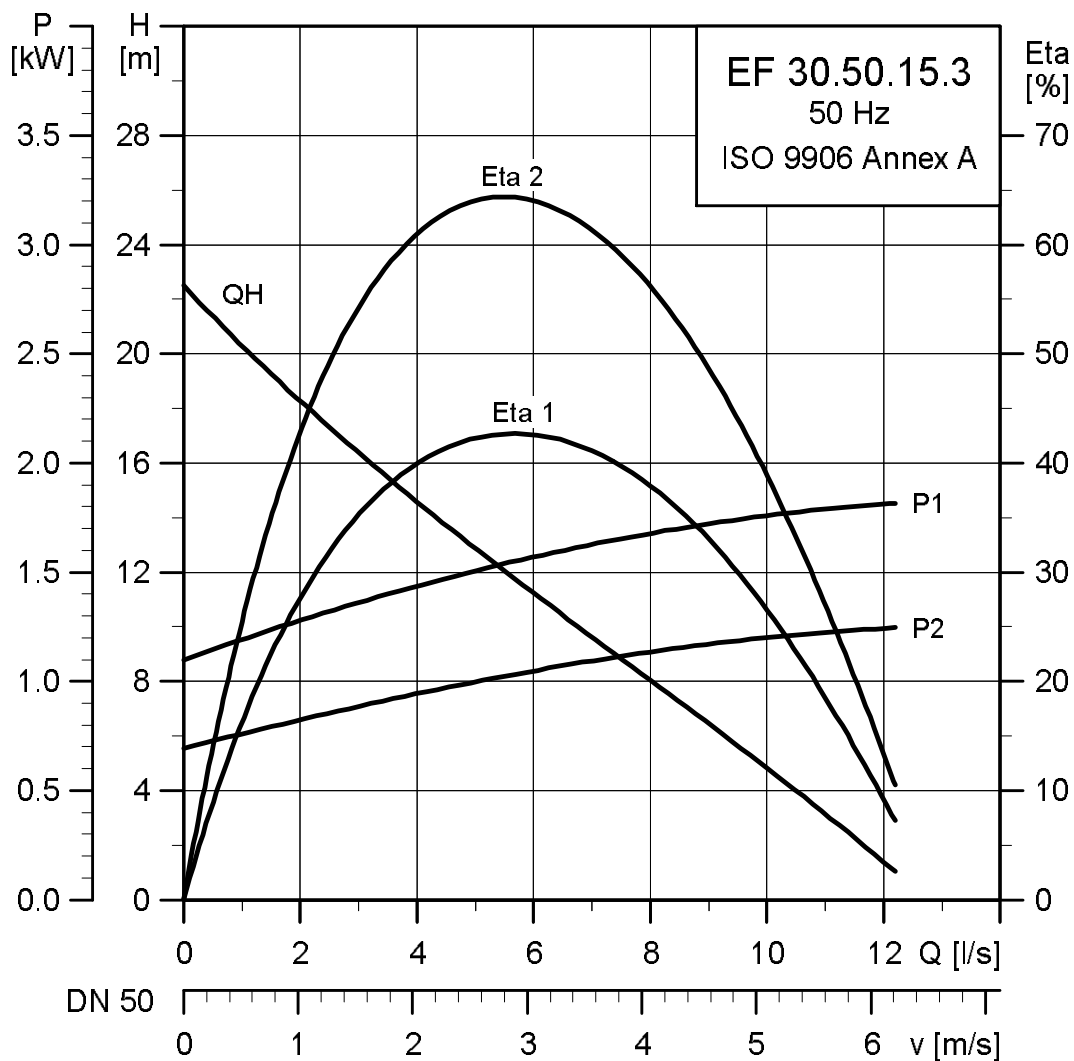

TM02 7465 1810

Electrical data

Voltage [V]	P1 [kW]	P2 [kW]	Number of poles	min^{-1}	Starting method	I_N			I_{start}			η_{motor} [%]			Cos ϕ			Moment of inertia [kgm ²]	Breakdown torque M_{max} [Nm]
						[A]	[A]	[A]	1/2	3/4	1/1	1/2	3/4	1/1	1/2	3/4	1/1		
3 x 400-415	2.2	1.5	2	2720	DOL	3.8	21		63	68	67	0.71	0.81	0.88	0.0039	12			

Pump data

Impeller type	Max. solids size [mm]	Max. number of starts per hour	Max. installation depth [m]	Enclosure class	Insulation class	Max. liquid temperature [°C]	pH	Ex class
Semi-open	30	30	10	IP68	F	40	4-10	Ex d IIB T4/ Ex n IIB T4

SL1.50.65

Performance curves, SL1.50.65.09.(E).(Ex).1

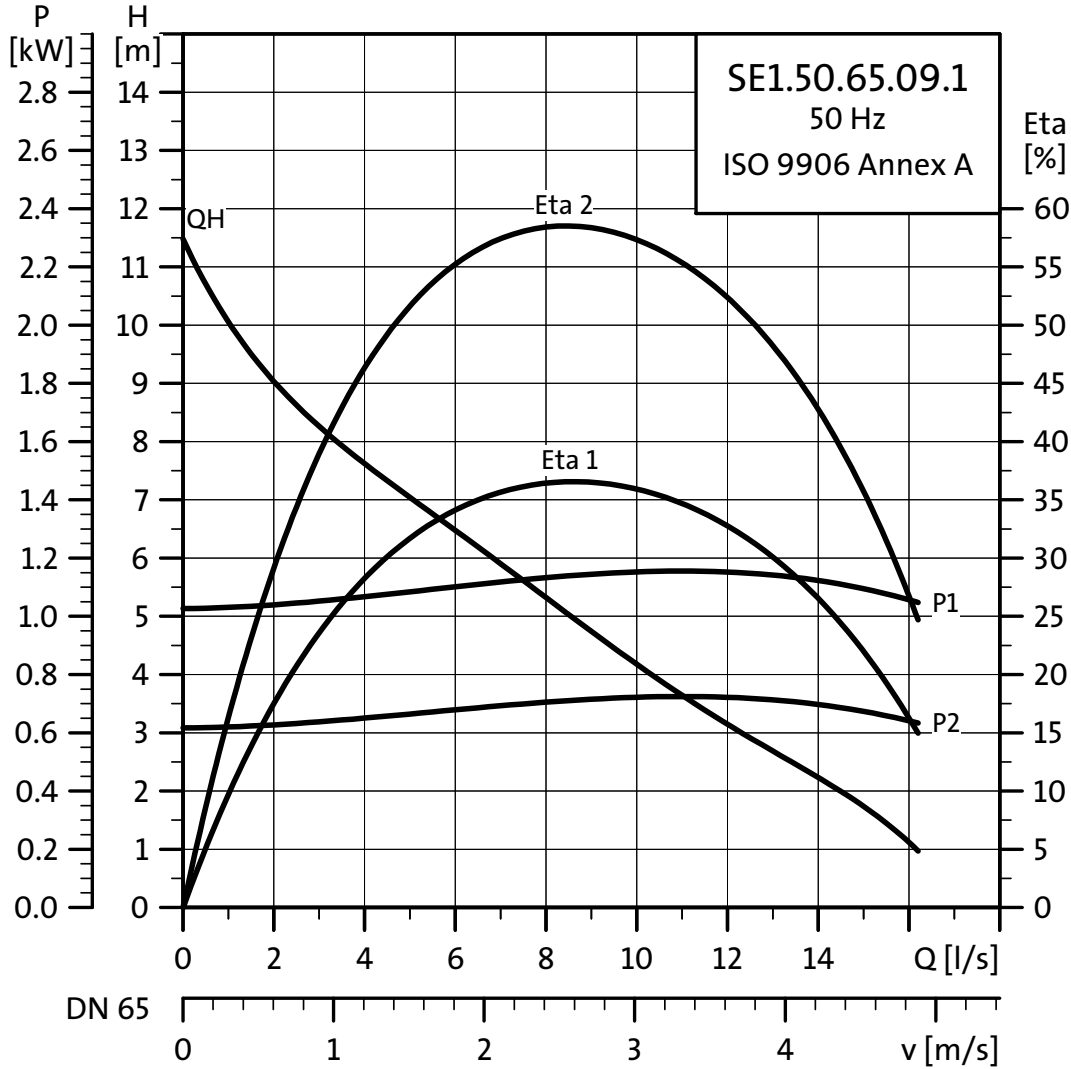

TM02 7574 1810

Electrical data

Voltage [V]	P1 [kW]	P2 [kW]	Number of poles	min ⁻¹	Starting method	Run capacitor [μF]	I _N		η _{motor} [%]			Cos φ			Moment of inertia [kgm ²]	Breakdown torque M _{max} [Nm]
							I _N [A]	I _{start} [A]	1/2	3/4	1/1	1/2	3/4	1/1		
1 x 230	1.3	0.9	2	2920	DOL	30	6.1	38	55	63	67	0.86	0.92	0.96	0.004	7

Pump data

Impeller type	Max. solids size [mm]	Max. number of starts per hour	Max. installation depth [m]	Enclosure class	Insulation class	Max. liquid temperature [°C]	pH	Ex class
Channel	65	30	10	IP68	F	40	4-10	Ex d IIB T4/ Ex n IIB T4

Performance curves, SL1.50.65.09.(E).(Ex).3

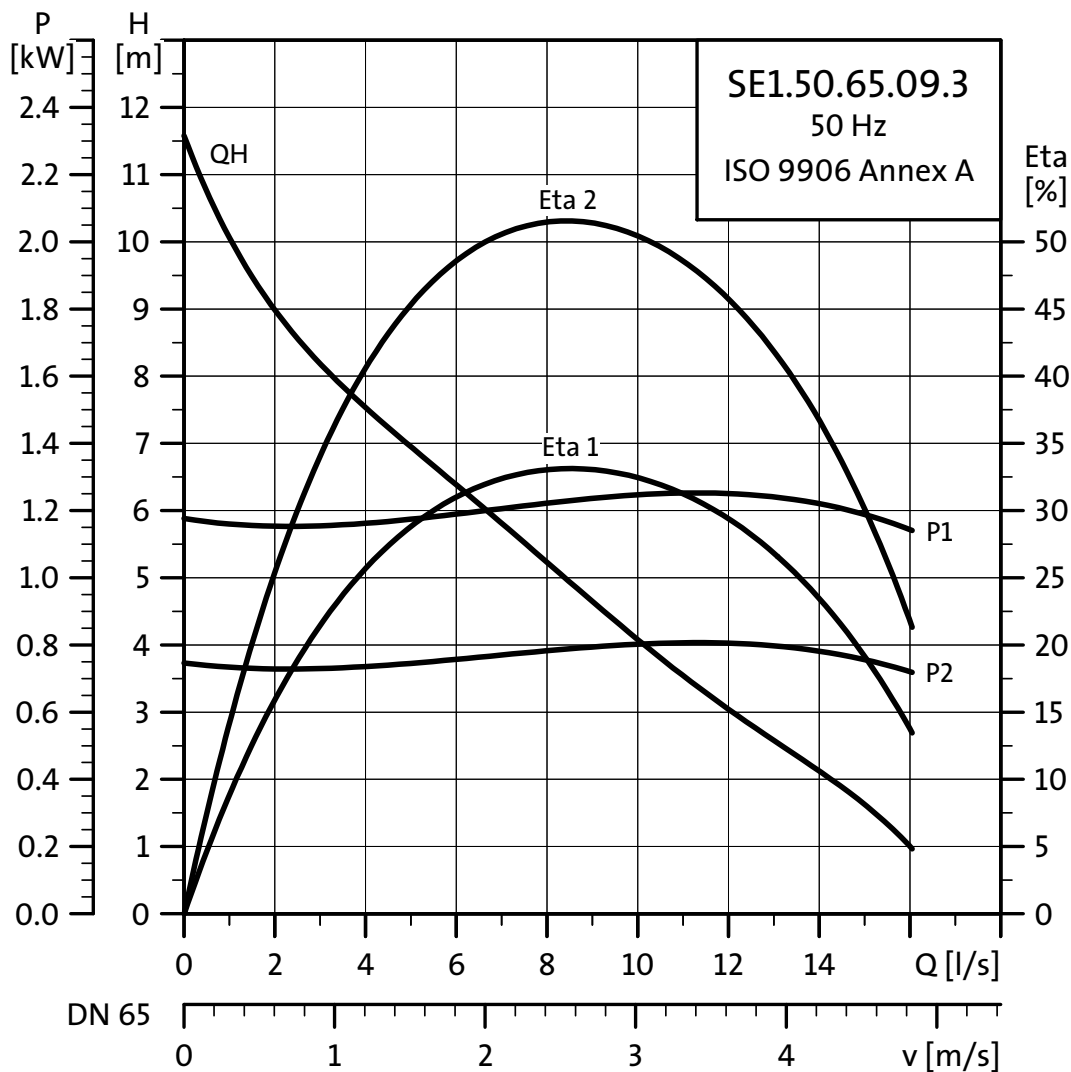

TM02 7484 1810

Electrical data

Voltage [V]	P1 [kW]	P2 [kW]	Number of poles	min ⁻¹	Starting method	I _N		η _{motor} [%]			Cos φ			Moment of inertia [kgm ²]	Breakdown torque M _{max.} [Nm]
						[A]	[A]	1/2	3/4	1/1	1/2	3/4	1/1		
3 x 230-240	1.4	0.9	2	2920	DOL	4.9	36	58	61	65	0.50	0.58	0.65	0.004	12
3 x 400-415	1.4	0.9	2	2920	DOL	2.8	21	58	61	65	0.58	0.68	0.76	0.004	12

Pump data

Impeller type	Max. solids size [mm]	Max. number of starts per hour	Max. installation depth [m]	Enclosure class	Insulation class	Max. liquid temperature [°C]	pH	Ex class
Channel	65	30	10	IP68	F	40	4-10	Ex d IIB T4/ Ex n IIB T4

Performance curves, SL1.50.65.11.(E).(Ex).1

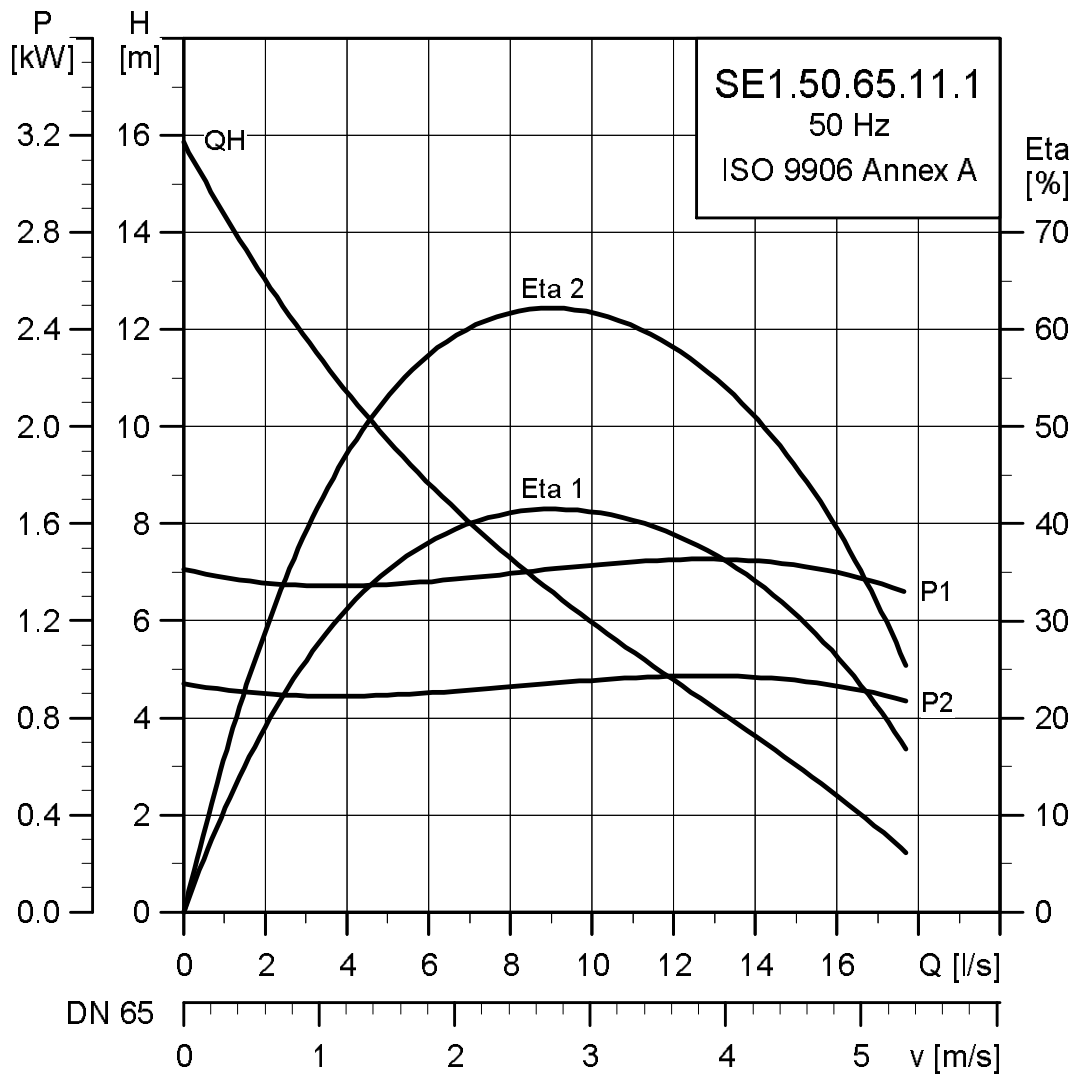

TM02 7774 1810

Electrical data

Voltage [V]	P1 [kW]	P2 [kW]	Number of poles	min ⁻¹	Starting method	Run capacitor [μF]	I _N		η _{motor} [%]			Cos φ			Moment of inertia [kgm ²]	Breakdown torque M _{max.} [Nm]
							I _N [A]	I _{start} [A]	1/2	3/4	1/1	1/2	3/4	1/1		
1 x 230	1.3	0.9	2	2920	DOL	30	6.1	38	55	63	67	0.86	0.92	0.96	0.004	7

Pump data

Impeller type	Max. solids size [mm]	Max. number of starts per hour	Max. installation depth [m]	Enclosure class	Insulation class	Max. liquid temperature [°C]	pH	Ex class
Channel	65	30	10	IP68	F	40	4-10	Ex d IIB T4/ Ex n IIB T4

Performance curves, SL1.50.65.11.(E).(Ex).3

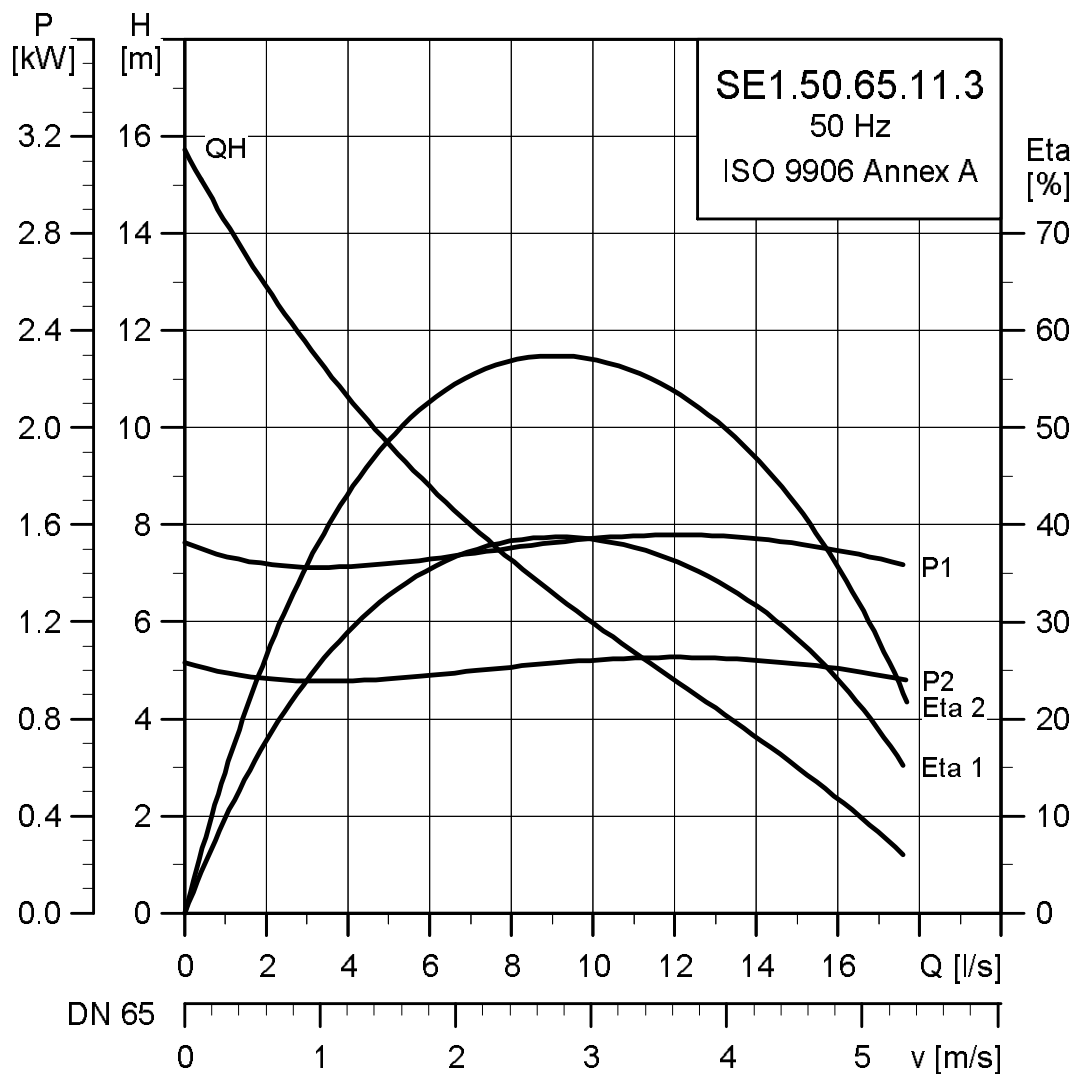

TM02 7474 1810

Electrical data

Voltage [V]	P1 [kW]	P2 [kW]	Number of poles	min ⁻¹	Starting method	I _N		I _{start}			η _{motor} [%]			Cos φ			Moment of inertia [kgm ²]	Breakdown torque M _{max.} [Nm]
						[A]	[A]	1/2	3/4	1/1	1/2	3/4	1/1					
3 x 230-240	1.6	1.1	2	2830	DOL	5.2	36	57	64	67	0.63	0.74	0.81	0.0043	12			
3 x 400-415	1.6	1.1	2	2830	DOL	3.1	21	57	64	67	0.63	0.74	0.81	0.0043	12			

Pump data

Impeller type	Max. solids size [mm]	Max. number of starts per hour	Max. installation depth [m]	Enclosure class	Insulation class	Max. liquid temperature [°C]	pH	Ex class
Channel	65	30	10	IP68	F	40	4-10	Ex d IIB T4/ Ex n IIB T4

Performance curves, SL1.50.65.15.(E).(Ex).3

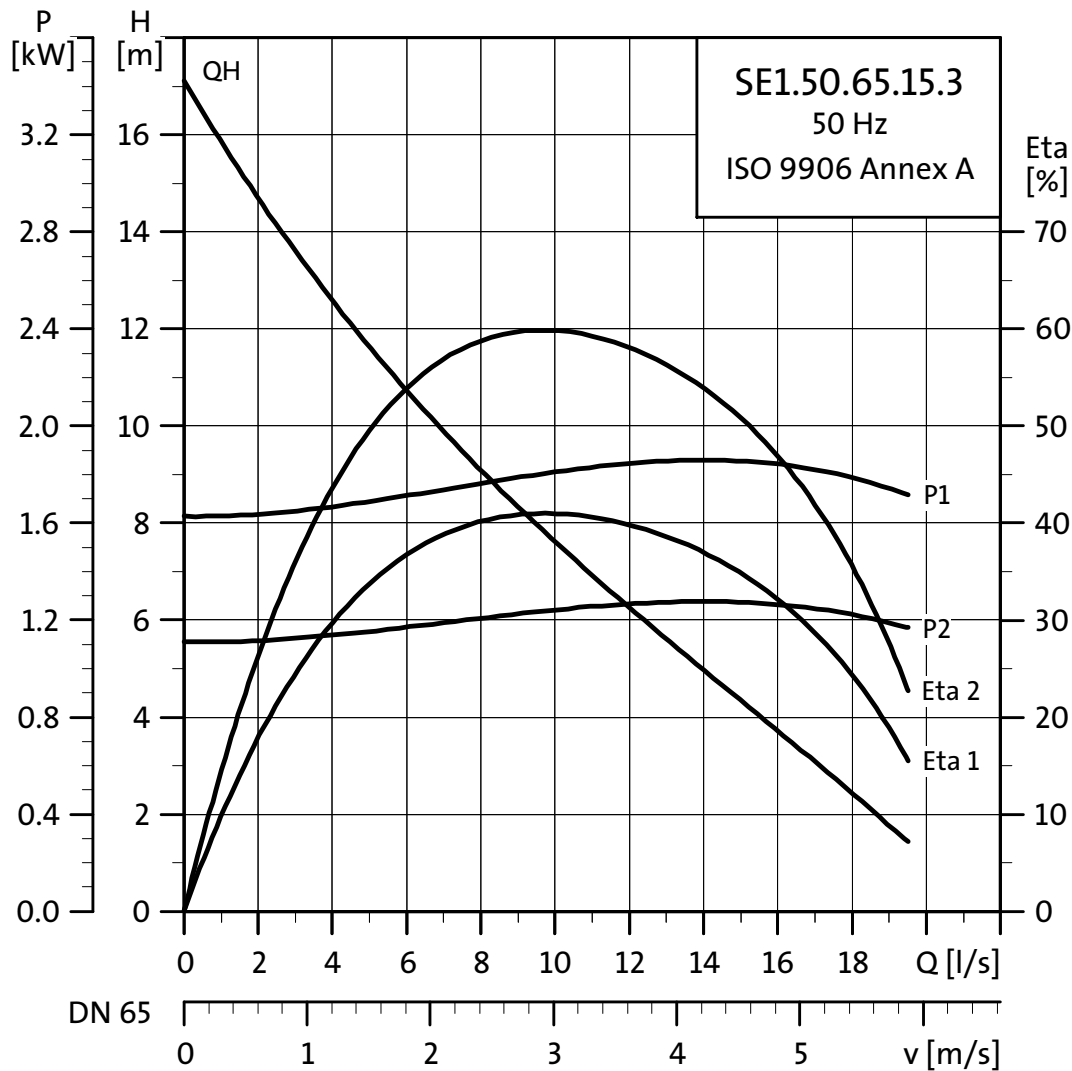

TM02 7473 1810

Electrical data

Voltage [V]	P1 [kW]	P2 [kW]	Number of poles	min ⁻¹	Starting method	I _N		η _{motor} [%]			Cos φ			Moment of inertia [kgm ²]	Breakdown torque M _{max.} [Nm]
						[A]	[A]	1/2	3/4	1/1	1/2	3/4	1/1		
3 x 230-240	2.2	1.5	2	2720	DOL	6.6	36	67	68	63	0.88	0.81	0.71	0.004	12
3 x 400-415	2.2	1.5	2	2720	DOL	3.8	21	67	68	63	0.88	0.81	0.71	0.004	12

Pump data

Impeller type	Max. solids size [mm]	Max. number of starts per hour	Max. installation depth [m]	Enclosure class	Insulation class	Max. liquid temperature [°C]	pH	Ex class
Channel	65	30	10	IP68	F	40	4-10	Ex d IIB T4/ Ex n IIB T4

SLV.65.65

Performance curves, SLV.65.65.09.(E).(Ex).1

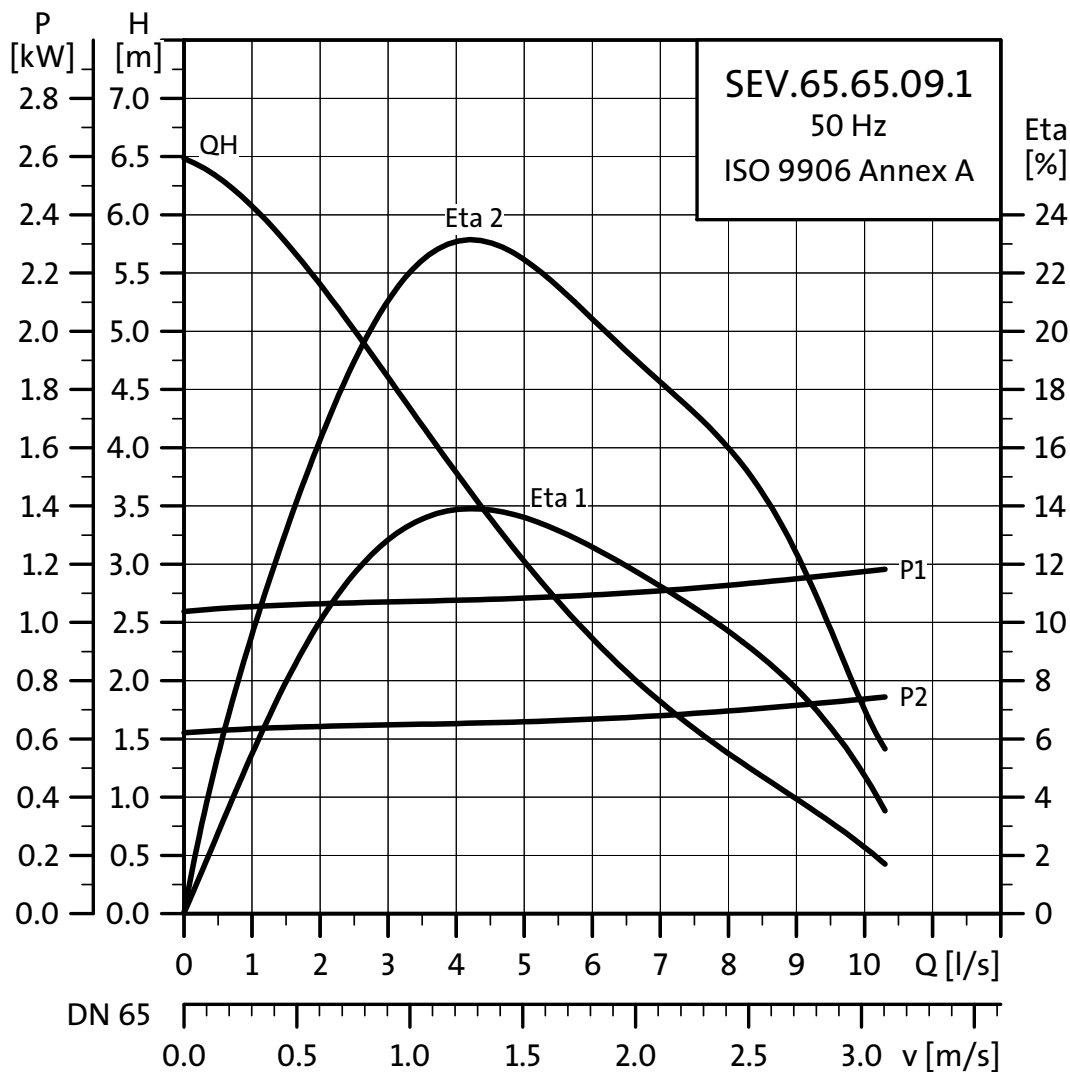

TM02 7483 1810

Electrical data

Voltage [V]	P1 [kW]	P2 [kW]	Number of poles	min ⁻¹	Starting method	Run capacitor [μF]	I _N			I _{start}			η _{motor} [%]			Cos φ		Moment of inertia [kgm ²]	Breakdown torque M _{max} [Nm]
							[A]	[A]	[A]	1/2	3/4	1/1	1/2	3/4	1/1				
1 x 230	1.3	0.9	2	2920	DOL	30	6.1	38	55	63	67	0.86	0.92	0.96	0.004	7			

Pump data

Impeller type	Max. solids size [mm]	Max. number of starts per hour	Max. installation depth [m]	Enclosure class	Insulation class	Max. liquid temperature [°C]	pH	Ex class
Channel	65	30	10	IP68	F	40	4-10	Ex d IIB T4/ Ex n IIB T4

Performance curves, SLV.65.65.09.(E).(Ex).3

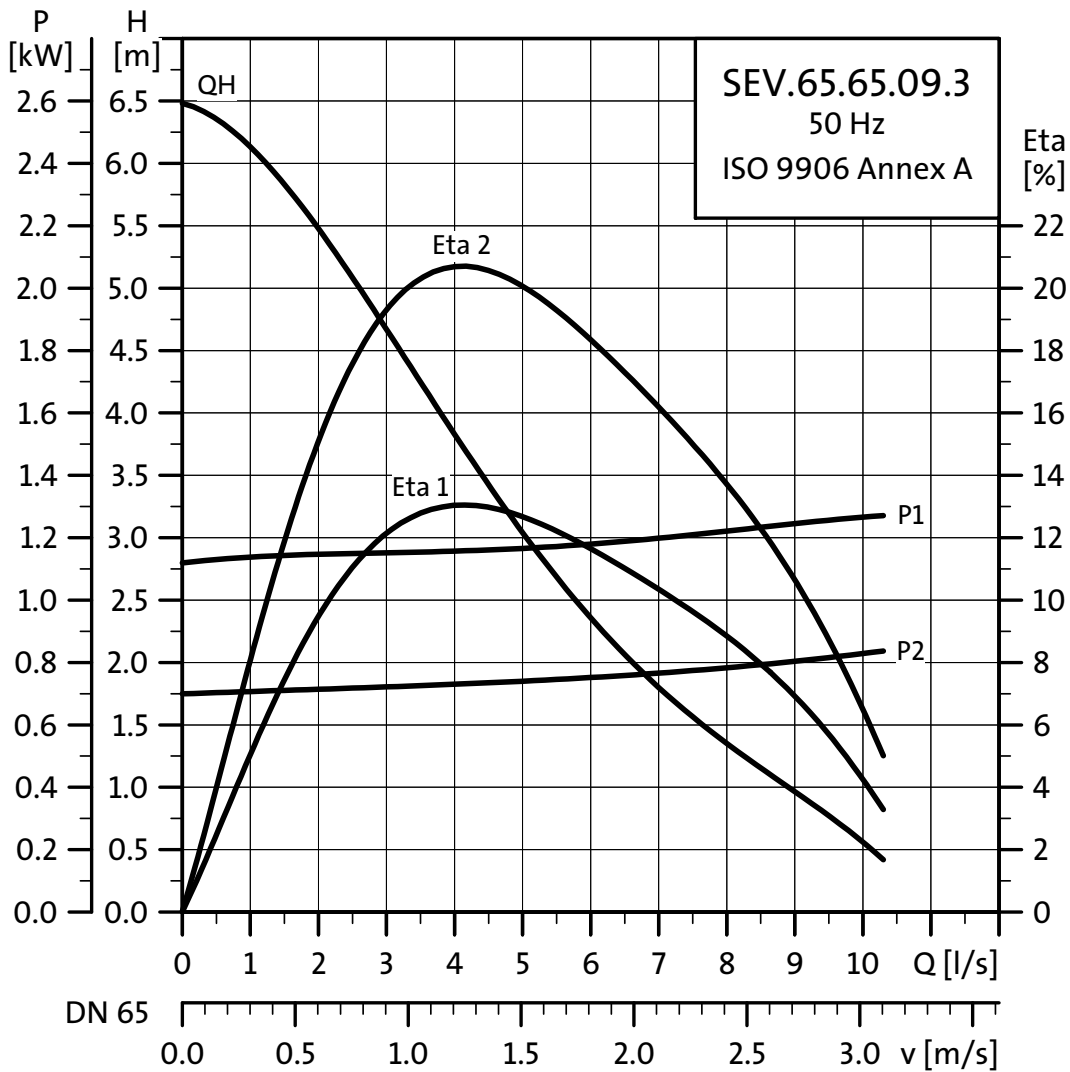

TM02 7482 1810

Electrical data

Voltage [V]	P1 [kW]	P2 [kW]	Number of poles	min ⁻¹	Starting method	I _N		η _{motor} [%]			Cos φ			Moment of inertia [kgm ²]	Breakdown torque M _{max.} [Nm]
						[A]	[A]	1/2	3/4	1/1	1/2	3/4	1/1		
3 x 230-240	1.4	0.9	2	2920	DOL	4.9	36	58	61	65	0.50	0.58	0.65	0.004	12
3 x 400-415	1.4	0.9	2	2920	DOL	2.8	21	58	61	65	0.58	0.68	0.76	0.004	12

Pump data

Impeller type	Max. solids size [mm]	Max. number of starts per hour	Max. installation depth [m]	Enclosure class	Insulation class	Max. liquid temperature [°C]	pH	Ex class
Channel	65	30	10	IP68	F	40	4-10	Ex d IIB T4/ Ex n IIB T4

Performance curves, SLV.65.65.11.(E).(Ex).1

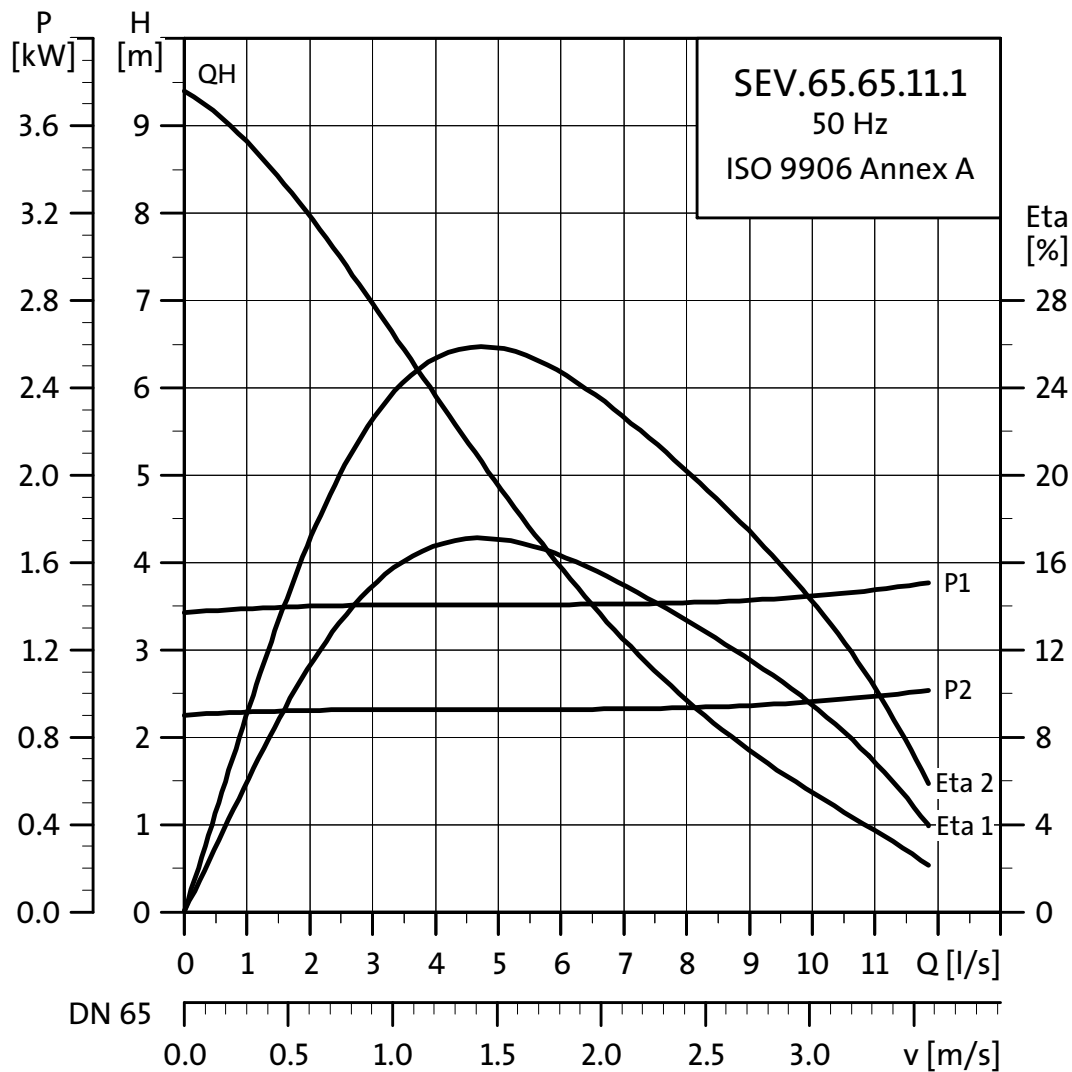

TM02 7472 1810

Electrical data

Voltage [V]	P1 [kW]	P2 [kW]	Number of poles	min ⁻¹	Starting method	Run capacitor [μF]	I _N [A]	I _{start} [A]	η _{motor} [%]			Cos φ			Moment of inertia [kgm ²]	Breakdown torque M _{max} [Nm]
									1/2	3/4	1/1	1/2	3/4	1/1		
1 x 230	1.3	0.9	2	2920	DOL	30	6.1	38	55	63	67	0.86	0.92	0.96	0.004	7

Pump data

Impeller type	Max. solids size [mm]	Max. number of starts per hour	Max. installation depth [m]	Enclosure class	Insulation class	Max. liquid temperature [°C]	pH	Ex class
Channel	65	30	10	IP68	F	40	4-10	Ex d IIB T4/ Ex n IIB T4

Performance curves, SLV.65.65.09.(E).(Ex).1

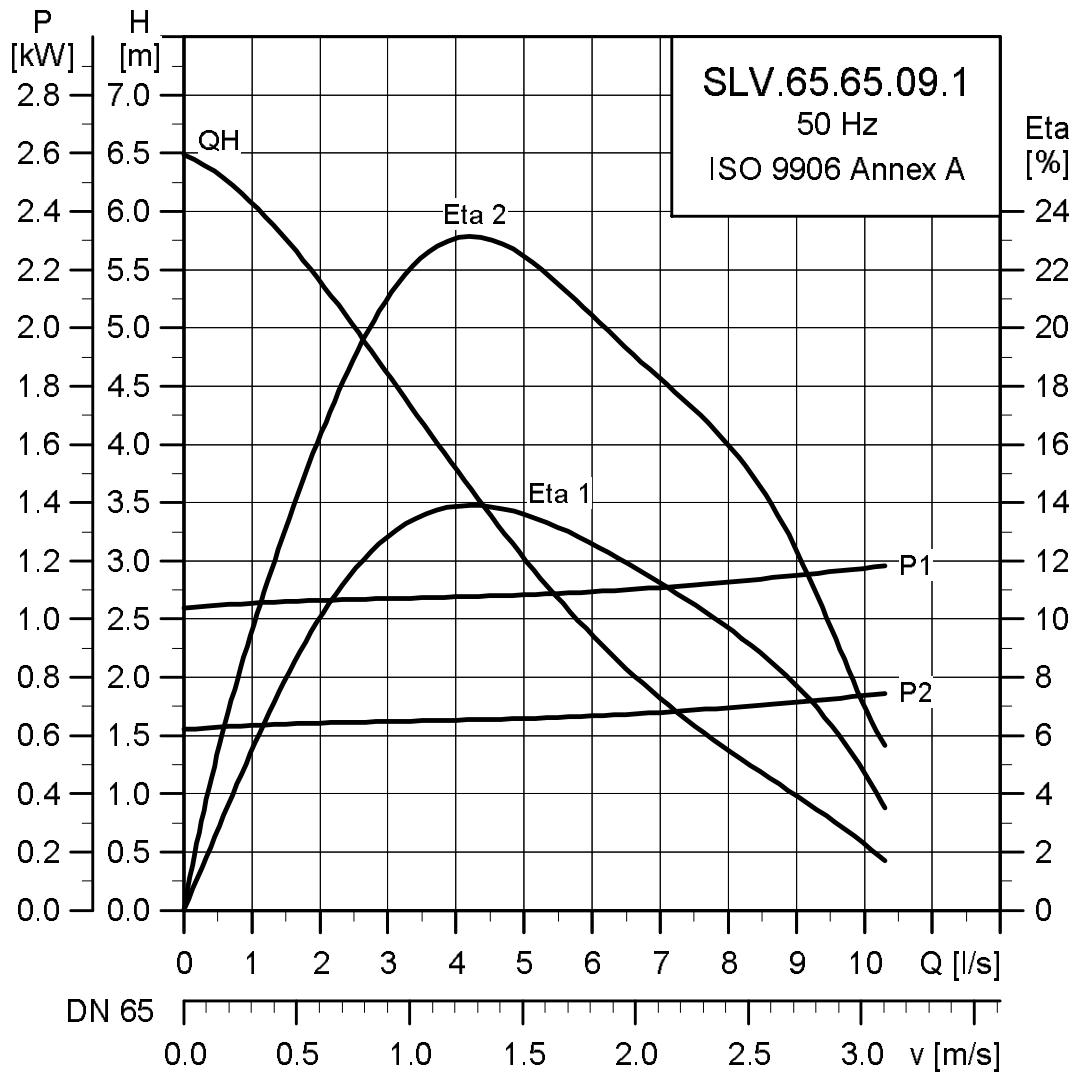

TMD4 7189 1810

Electrical data

Voltage [V]	P1 [kW]	P2 [kW]	Number of poles	min ⁻¹	Starting method	Run capacitor [μF]	I _N		η _{motor} [%]			Cos φ			Moment of inertia [kgm ²]	Breakdown torque M _{max} [Nm]
							[A]	[A]	1/2	3/4	1/1	1/2	3/4	1/1		
1 x 230	1.3	0.9	2	2920	DOL	30	6.1	38	55	63	67	0.86	0.92	0.96	0.004	7

Pump data

Impeller type	Max. solids size [mm]	Max. number of starts per hour	Max. installation depth [m]	Enclosure class	Insulation class	Max. liquid temperature [°C]	pH	Ex class
Channel	65	30	10	IP68	F	40	4-10	Ex d IIB T4/ Ex n IIB T4

Performance curves, SLV.65.65.09.(E).(Ex).3

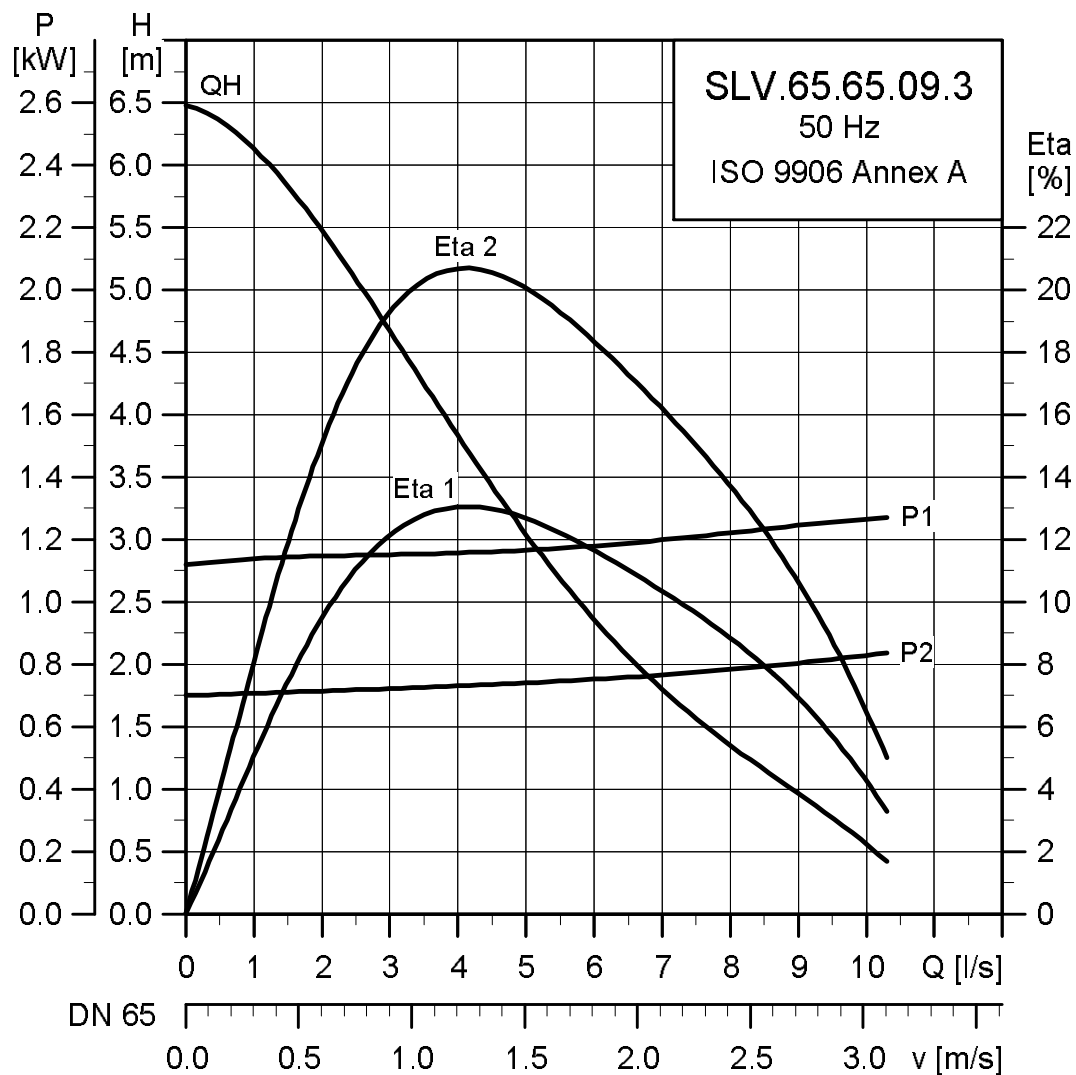

TM04 7190 1810

Electrical data

Voltage [V]	P1 [kW]	P2 [kW]	Number of poles	min ⁻¹	Starting method	I _N		η _{motor} [%]			Cos φ			Moment of inertia [kgm ²]	Breakdown torque M _{max.} [Nm]
						[A]	[A]	1/2	3/4	1/1	1/2	3/4	1/1		
3 x 230-240	1.4	0.9	2	2920	DOL	4.9	36	58	61	65	0.50	0.58	0.65	0.004	12
3 x 400-415	1.4	0.9	2	2920	DOL	2.8	21	58	61	65	0.58	0.68	0.76	0.004	12

Pump data

Impeller type	Max. solids size [mm]	Max. number of starts per hour	Max. installation depth [m]	Enclosure class	Insulation class	Max. liquid temperature [°C]	pH	Ex class
Channel	65	30	10	IP68	F	40	4-10	Ex d IIB T4/ Ex n IIB T4

Performance curves, SLV.65.65.11.(E).(Ex).1

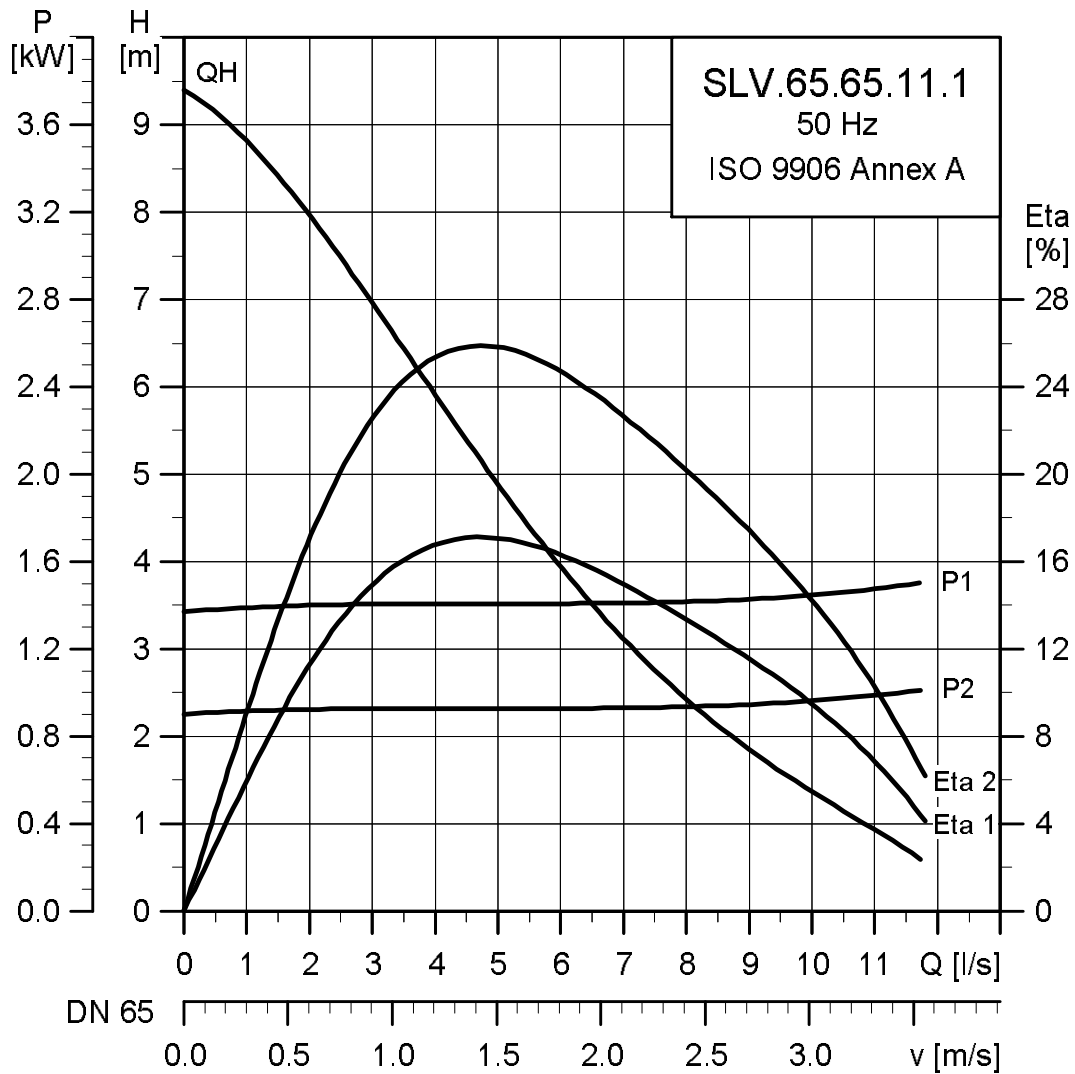

TM04 7191 1810

Electrical data

Voltage [V]	P1 [kW]	P2 [kW]	Number of poles	min ⁻¹	Starting method	Run capacitor [μF]	I _N			I _{start}			η _{motor} [%]			Cos φ			Moment of inertia [kgm ²]	Breakdown torque M _{max.} [Nm]
							[A]	[A]	[A]	1/2	3/4	1/1	1/2	3/4	1/1	1/2	3/4	1/1		
1 x 230	1.3	0.9	2	2920	DOL	30	6.1	38	55	63	67	0.86	0.92	0.96	0.004	7				

Pump data

Impeller type	Max. solids size [mm]	Max. number of starts per hour	Max. installation depth [m]	Enclosure class	Insulation class	Max. liquid temperature [°C]	pH	Ex class
Channel	65	30	10	IP68	F	40	4-10	Ex d IIB T4/ Ex n IIB T4

Performance curves, SLV.65.65.11.(E).(Ex).3

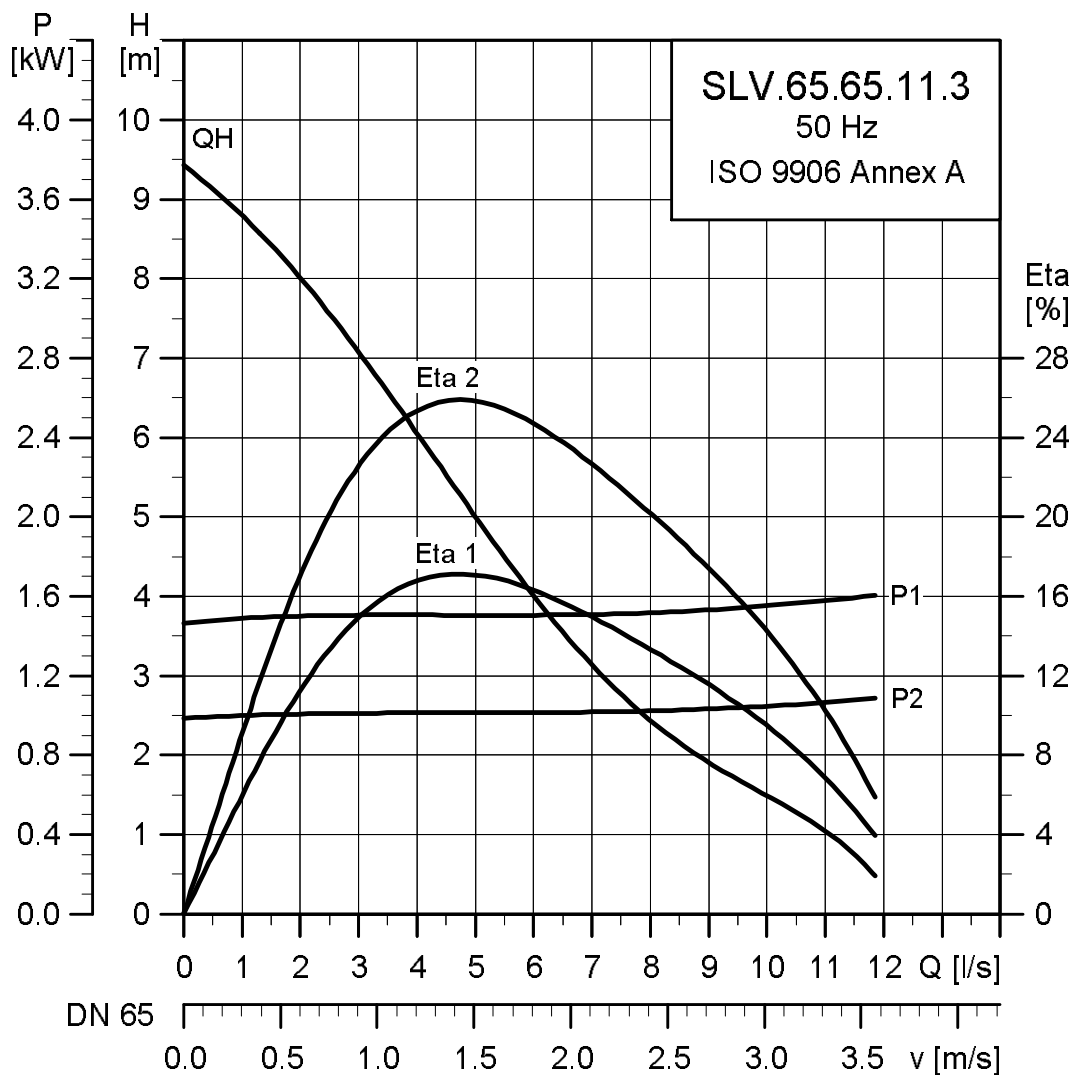

TM04 7192 1810

Electrical data

Voltage [V]	P1 [kW]	P2 [kW]	Number of poles	min ⁻¹	Starting method	I _N			I _{start}			η _{motor} [%]			Cos φ			Moment of inertia [kgm ²]	Breakdown torque M _{max.} [Nm]
						[A]	[A]	[A]	1/2	3/4	1/1	1/2	3/4	1/1	1/2	3/4	1/1		
3 x 230-240	1.4	0.9	2	2920	DOL	4.9	36	58	61	65	0.50	0.58	0.65	0.004	12				
3 x 400-415	1.4	0.9	2	2920	DOL	2.8	21	58	61	65	0.58	0.68	0.76	0.004	12				

Pump data

Impeller type	Max. solids size [mm]	Max. number of starts per hour	Max. installation depth [m]	Enclosure class	Insulation class	Max. liquid temperature [°C]	pH	Ex class
Channel	65	30	10	IP68	F	40	4-10	Ex d IIB T4/ Ex n IIB T4

Performance curves, SLV.65.65.15.(E).(Ex).3

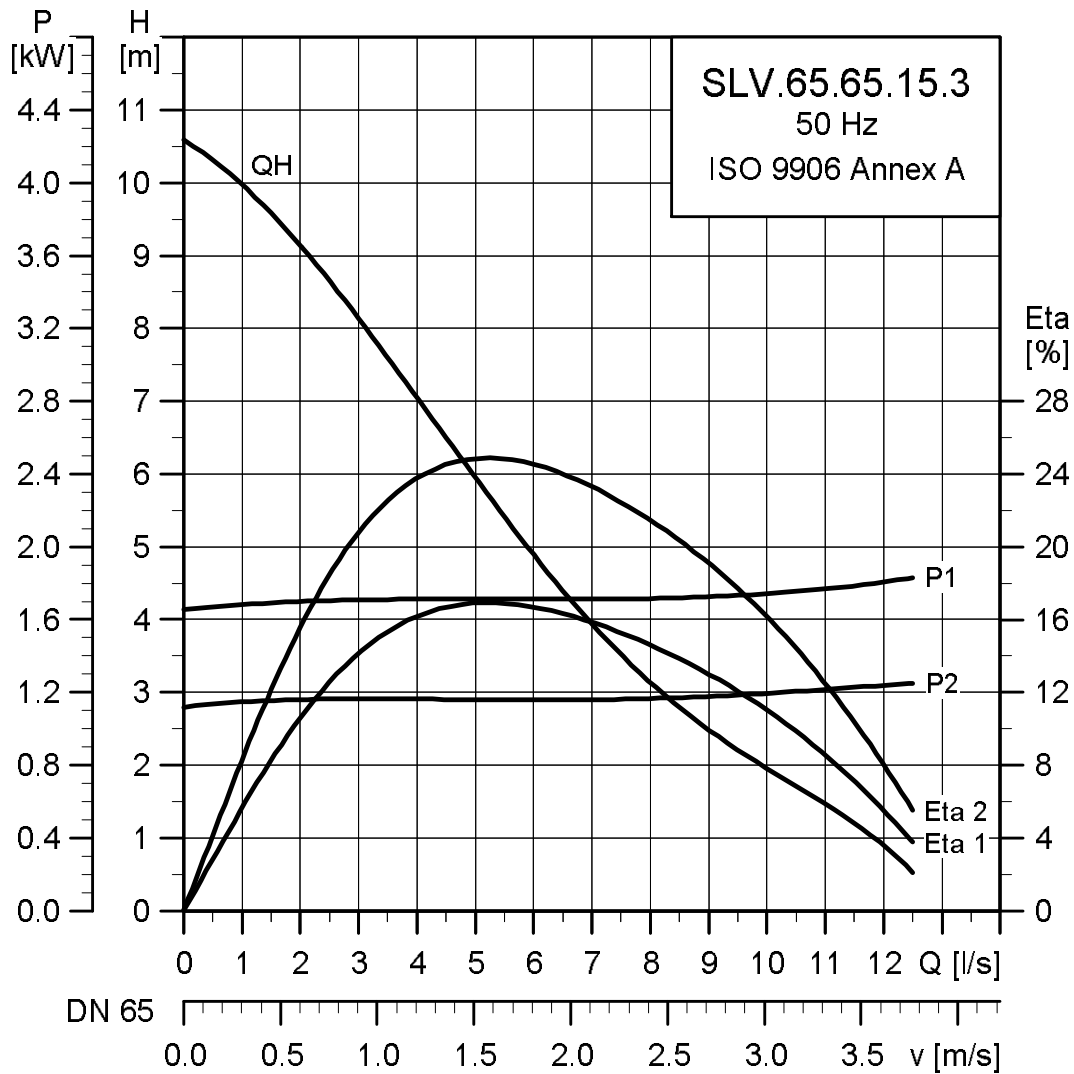

TM04 7193 1810

Electrical data

Voltage [V]	P1 [kW]	P2 [kW]	Number of poles	min ⁻¹	Starting method	I _N [A]	I _{start} [A]	η _{motor} [%]			Cos φ			Moment of inertia [kgm ²]	Breakdown torque M _{max.} [Nm]
								1/2	3/4	1/1	1/2	3/4	1/1		
3 x 230-240	1.4	0.9	2	2920	DOL	4.9	36	58	61	65	0.50	0.58	0.65	0.004	12
3 x 400-415	1.4	0.9	2	2920	DOL	2.8	21	58	61	65	0.58	0.68	0.76	0.004	12

Pump data

Impeller type	Max. solids size [mm]	Max. number of starts per hour	Max. installation depth [m]	Enclosure class	Insulation class	Max. liquid temperature [°C]	pH	Ex class
Channel	65	30	10	IP68	F	40	4-10	Ex d IIB T4/ Ex n IIB T4

DP and EF standard and AUTO_{ADAPT} pumps

DP10.50.0.9 - 1.5

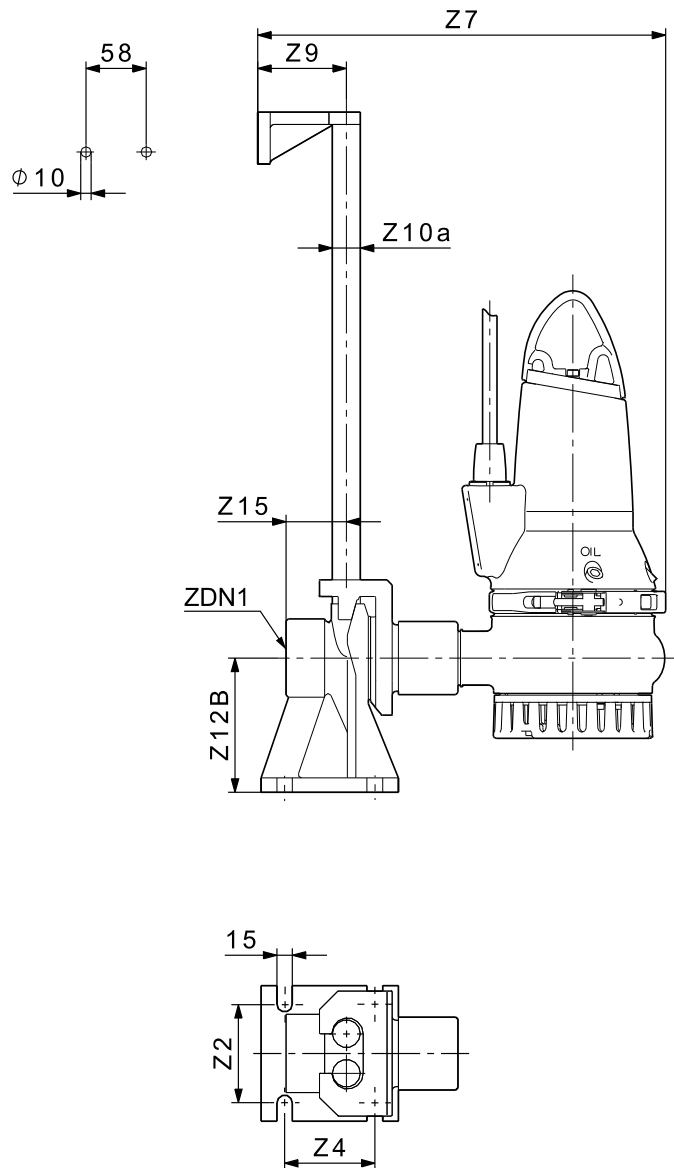

TM04 5073 1310

Fig. 32 One-pump installation on auto-coupling

Power [kW]	Z2	Z4	Z7	Z9	Z10a	Z12B	Z15	ZDN1
0.9 - 1.5	95	87	427	85	3/4"	129	58	Rp 2

DP10.50.0.9 - 1.5 AUTO_{ADAPT}

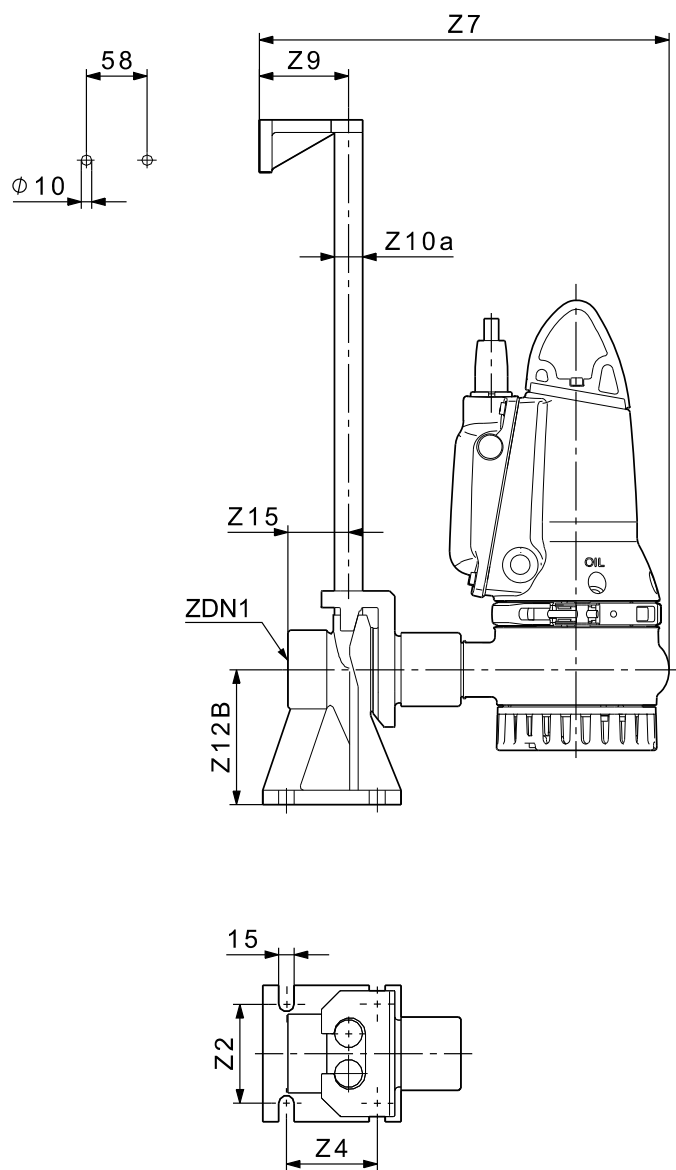

TM04 5560 1310

Fig. 33 One-pump installation on auto-coupling

Power [kW]	Z2	Z4	Z7	Z9	Z10a	Z12B	Z15	ZDN1
0.9 - 1.5	95	87	427	85	3/4"	129	58	Rp 2

DP10.65.26

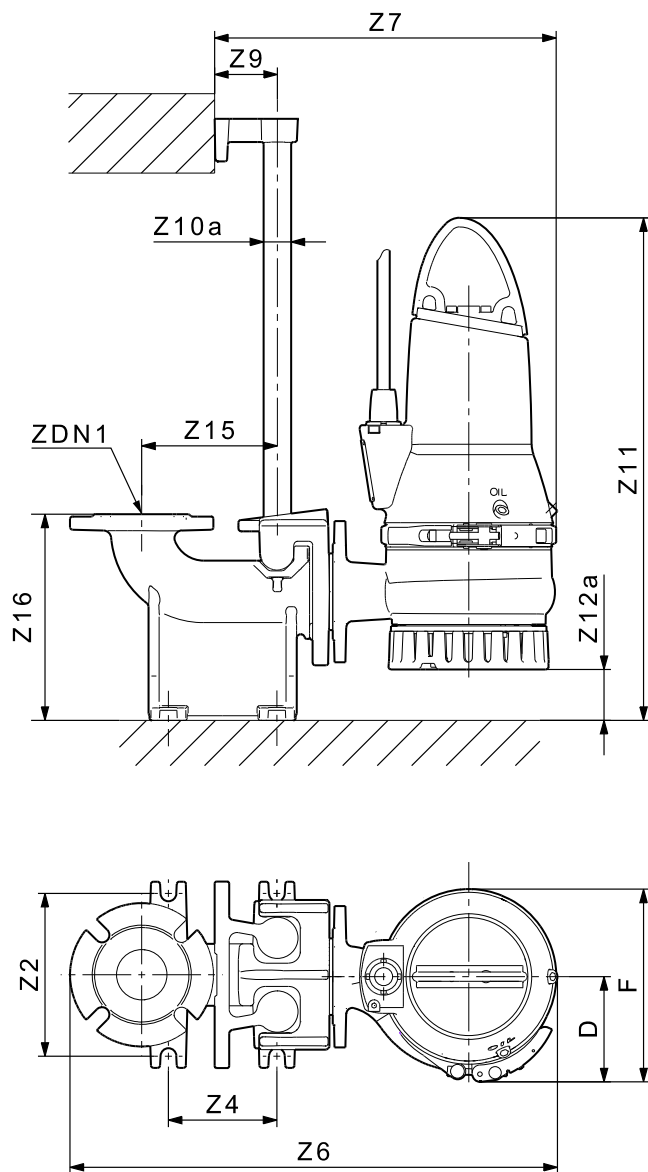

TM02 7346 1310

Fig. 34 One-pump installation on auto-coupling

Power [kW]	D	F	Z2	Z4	Z6	Z7	Z9	Z10a	Z11	Z12a	Z15	Z16	ZDN1
2.6	137	252	210	140	623	436	81	1 1/2"	656	64	175	266	DN 65

DP10.65.26 AUTO_{ADAPT}

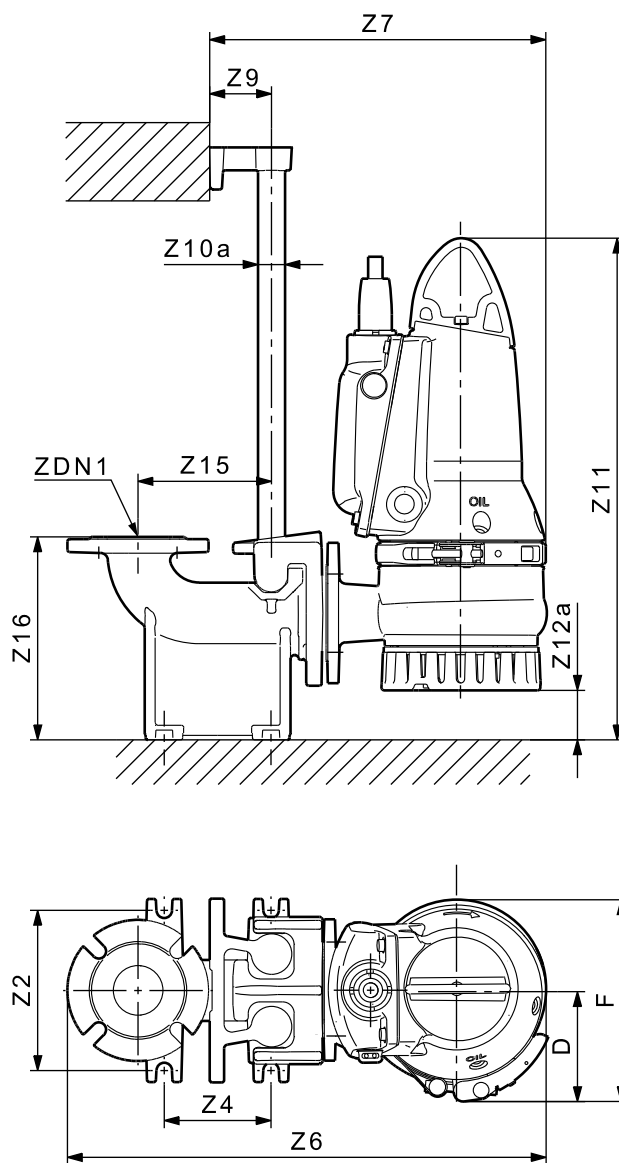

TM04 4864 1310

Fig. 35 One-pump installation on auto-coupling

Power [kW]	D	F	Z2	Z4	Z6	Z7	Z9	Z10a	Z11	Z12a	Z15	Z16	ZDN1
2.6	137	252	210	140	623	436	81	1 1/2"	656	64	175	266	DN 65

DP10.50, EF30.50

DP10.50

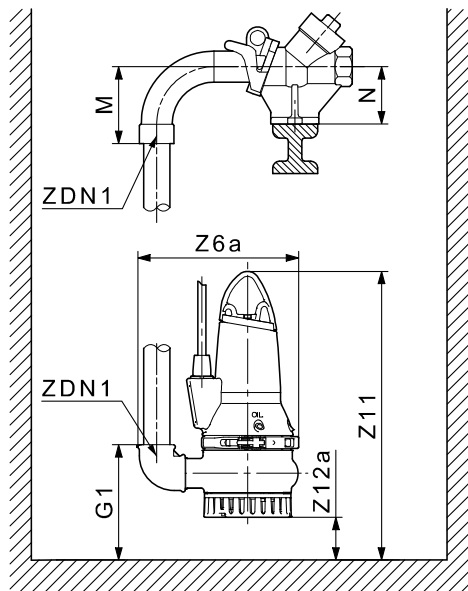

EF30.50

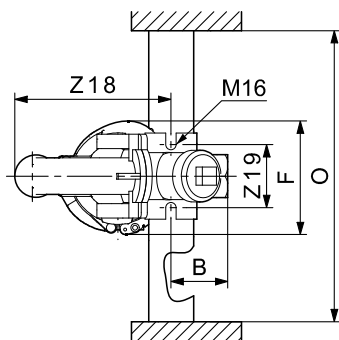
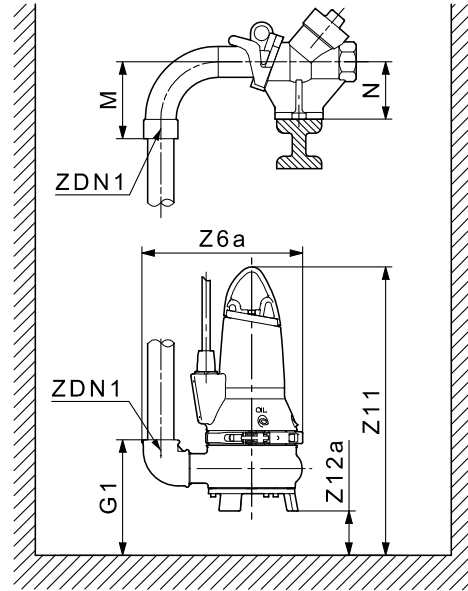

TM04 5076 1310

Fig. 36 One-pump installation on hookup auto-coupling

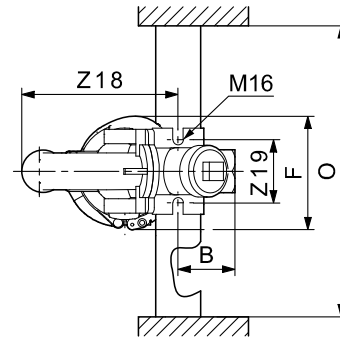

TM04 5077 1310

Fig. 37 One-pump installation on hookup auto-coupling

Power [kW]	B	F	G1	Z6a	M	N	O	Z11	Z12a	Z18	Z19	ZDN1
DP 0.6, 0.9 and 1.5	75	218	160	325	140	100	600	523	30	286	110	Rp 2
EF 0.6, 0.9 and 1.5	75	218	163	325	140	100	600	520	30	286	110	DN 65

DP10.50 AUTO_{ADAPT}, EF30.50 AUTO_{ADAPT}

DP10.50

EF30.50

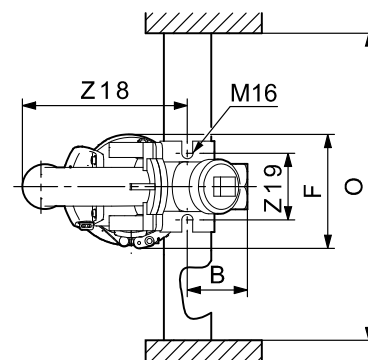
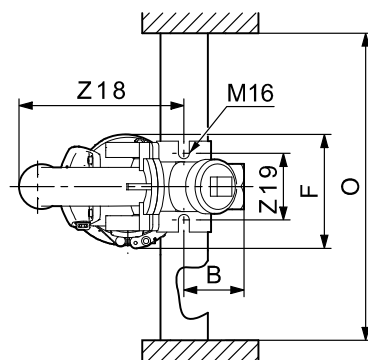
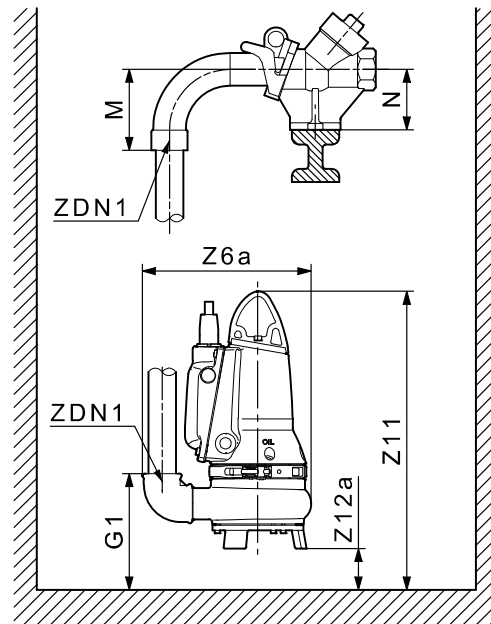
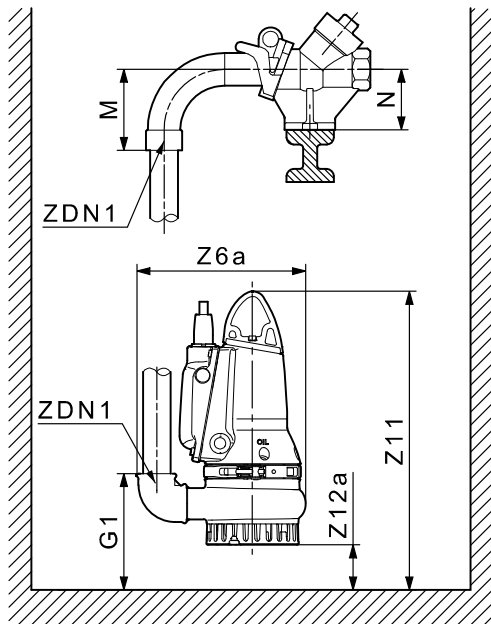

TM04 4865 1310

Fig. 38 One-pump installation on hookup auto-coupling

Power [kW]	B	F	G1	Z6a	M	N	O	Z11	Z12a	Z18	ZDN1	Z19
DP 0.6, 0.9 and 1.5	75	218	160	325	140	100	600	523	30	286	Rp 2	110
EF 0.6, 0.9 and 1.5	75	218	163	325	140	100	600	520	30	286	Rp 2	110

DP10.50, DP10.65

DP10.50

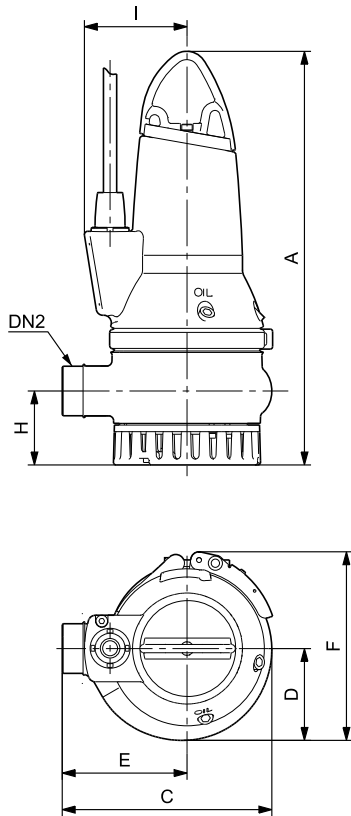

Fig. 39 Free-standing installation

TM02 7231 1310

DP10.65

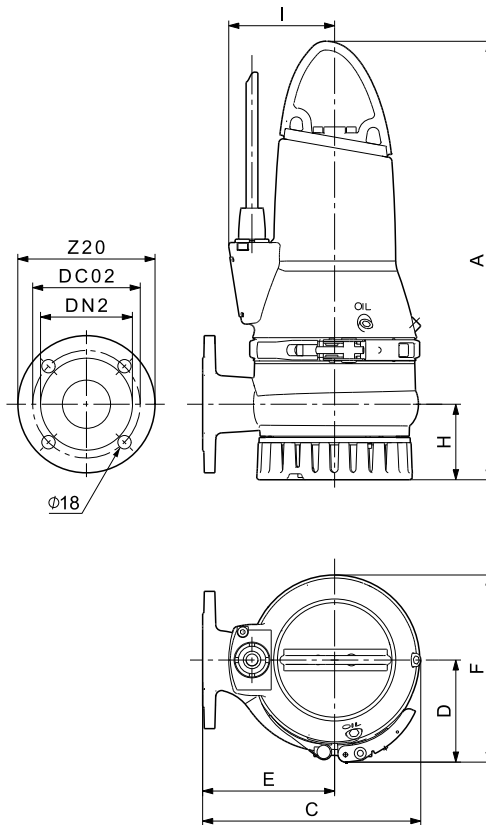
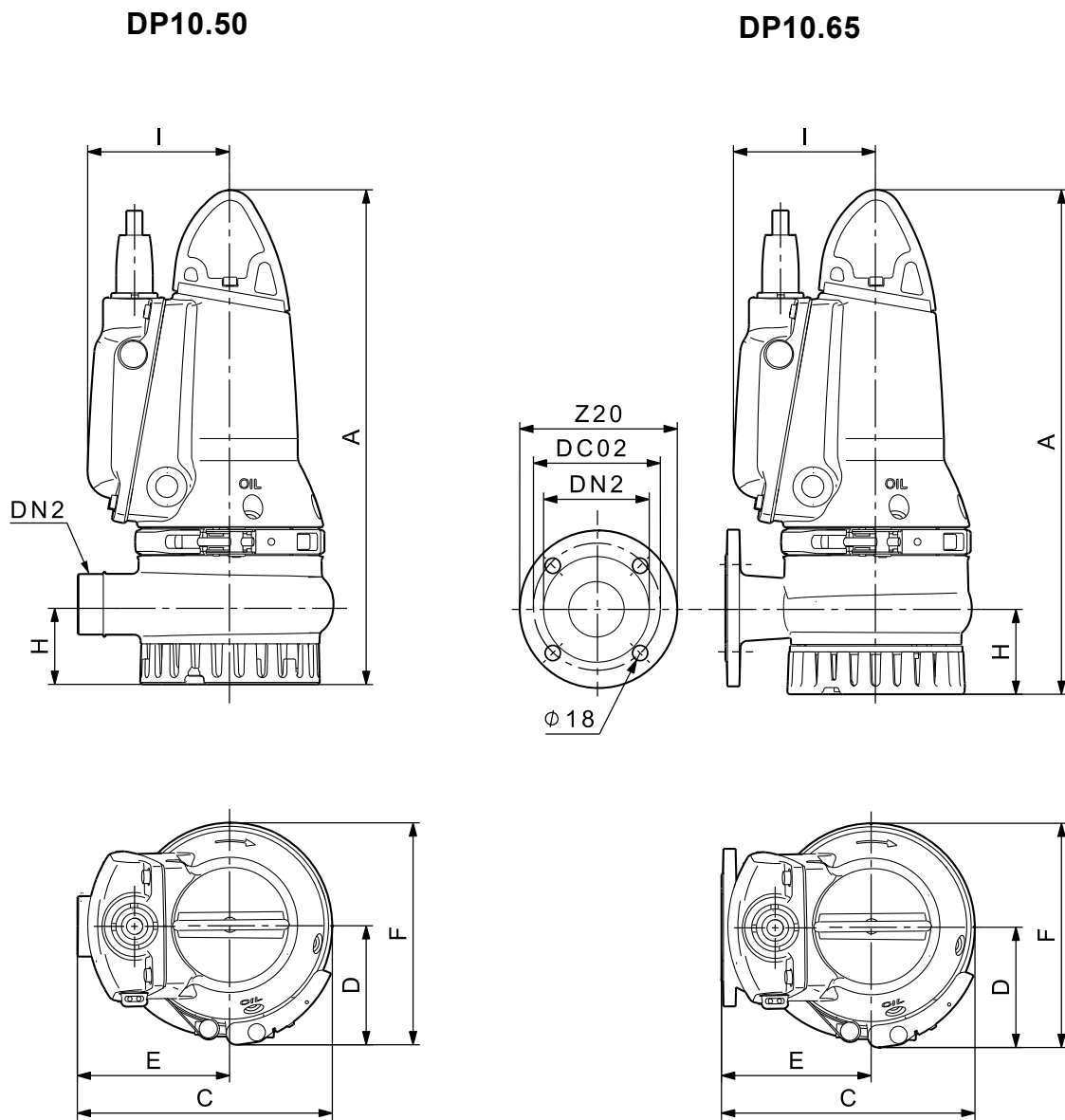

Fig. 40 Free-standing installation

TM02 7224 1310

Power [kW]	A	C	D	E	F	H	Ø L	Ø M	DN2
0.6, 0.9 and 1.5	493	252	117	150	218	87	-	-	R 2
2.6	592	294	137	180	252	102	143	185	DN 65

DP10.50 AUTO_{ADAPT}, DP10.65 AUTO_{ADAPT}



TM04 4866 1310

Fig. 41 Free-standing installation

Power [kW]	A	C	D	E	F	H	DC02	Z20	DN2	I
0.6, 0.9 and 1.5	493	252	117	150	218	87	-	-	R 2	141
2.6	592	294	137	180	252	102	143	185	DN 65	166

EF30.50

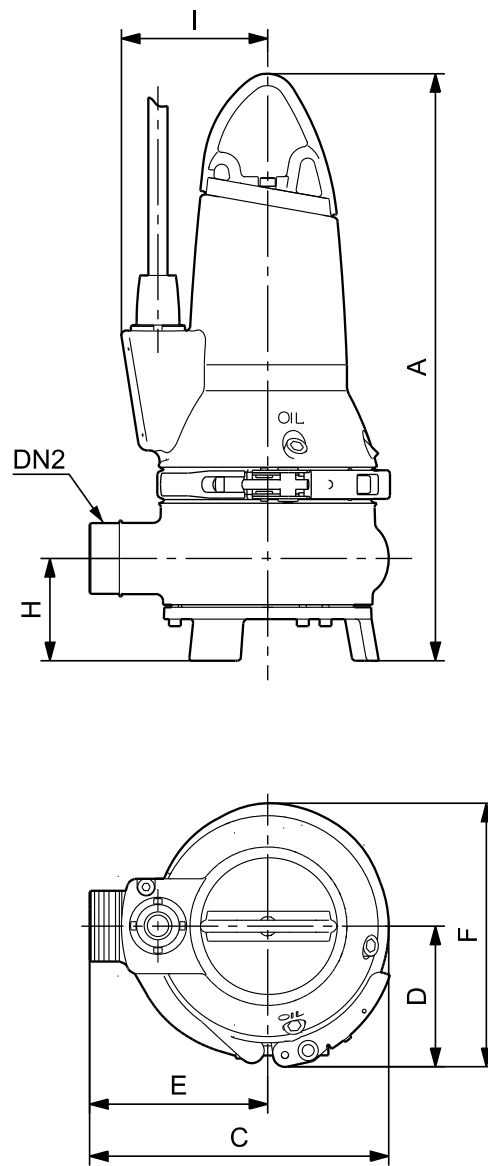
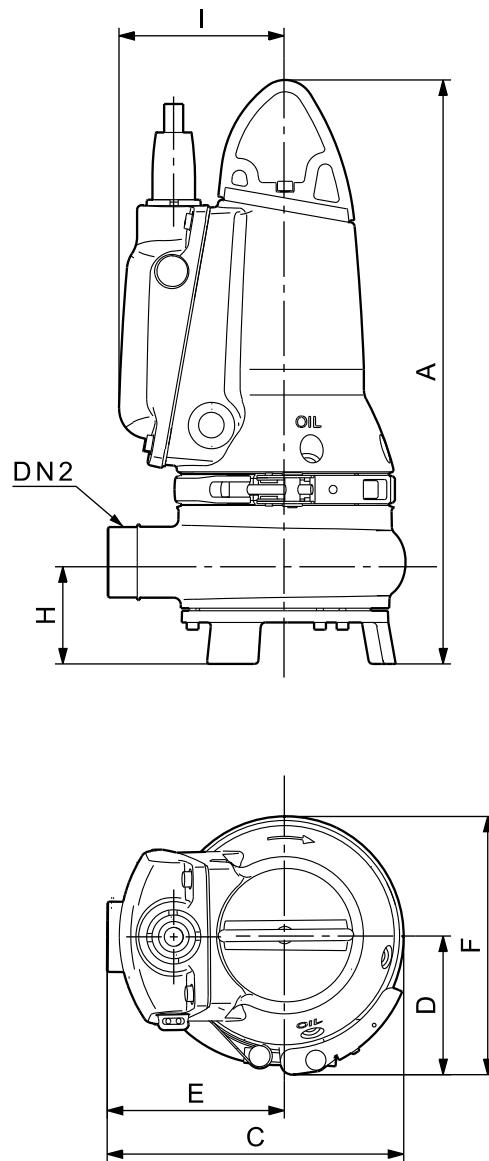

Fig. 42 Free-standing installation

Power [kW]	A	C	D	E	F	H	DN2
0.6, 0.9 and 1.5	494	252	117	102	218	84	R 2

TM04 5074 1310

EF30.50 AUTO_{ADAPT}



TM04 4867 1310

Fig. 43 Free-standing installation

Power [kW]	A	C	D	E	F	H	I	DN2
0.6, 0.9 and 1.5	490	252	117	150	218	84	141	R 2

SL1 and SLV standard and AUTO_{ADAPT} pumps

SL1.50, SLV.65

SL1.50

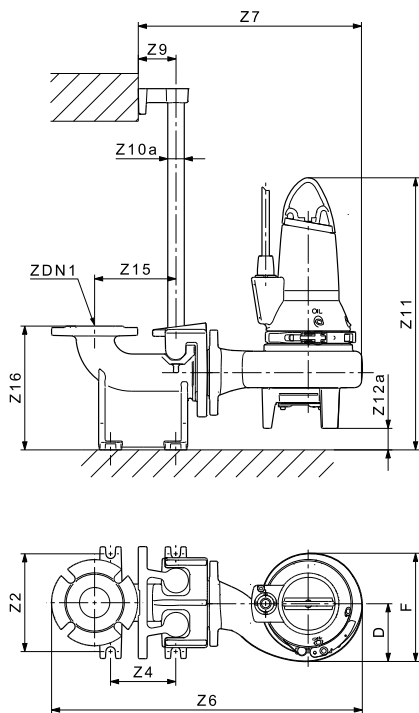

Fig. 44 One-pump installation on auto-coupling

SLV.65

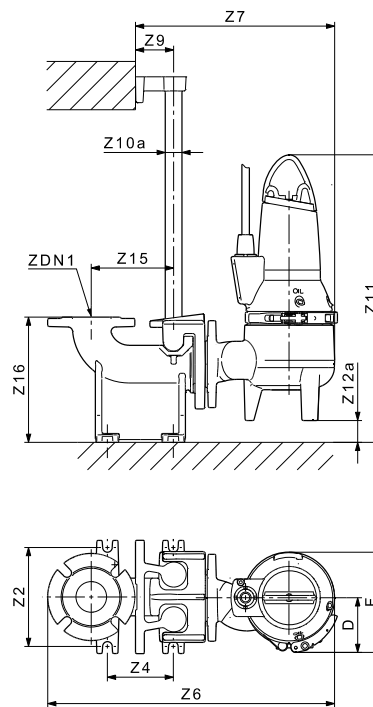

Fig. 45 One-pump installation on auto-coupling

Pump type	Power [kW]	D	F	Z2	Z4	Z6	Z7	Z9	Z10a	Z11	Z12a	Z15	Z16	ZDN1
SL1	0.9, 1.1 and 1.5	126	236	210	140	661	474	81	1 1/2"	588	43	175	266	DN 65
SLV	0.9, 1.1 and 1.5	119	216	210	140	598	412	81	1 1/2"	610	45	175	266	DN 65

Dimensions

SL1, SLV, DP, EF pumps

SL1.50 AUTO_{ADAPT}, SLV.65 AUTO_{ADAPT}

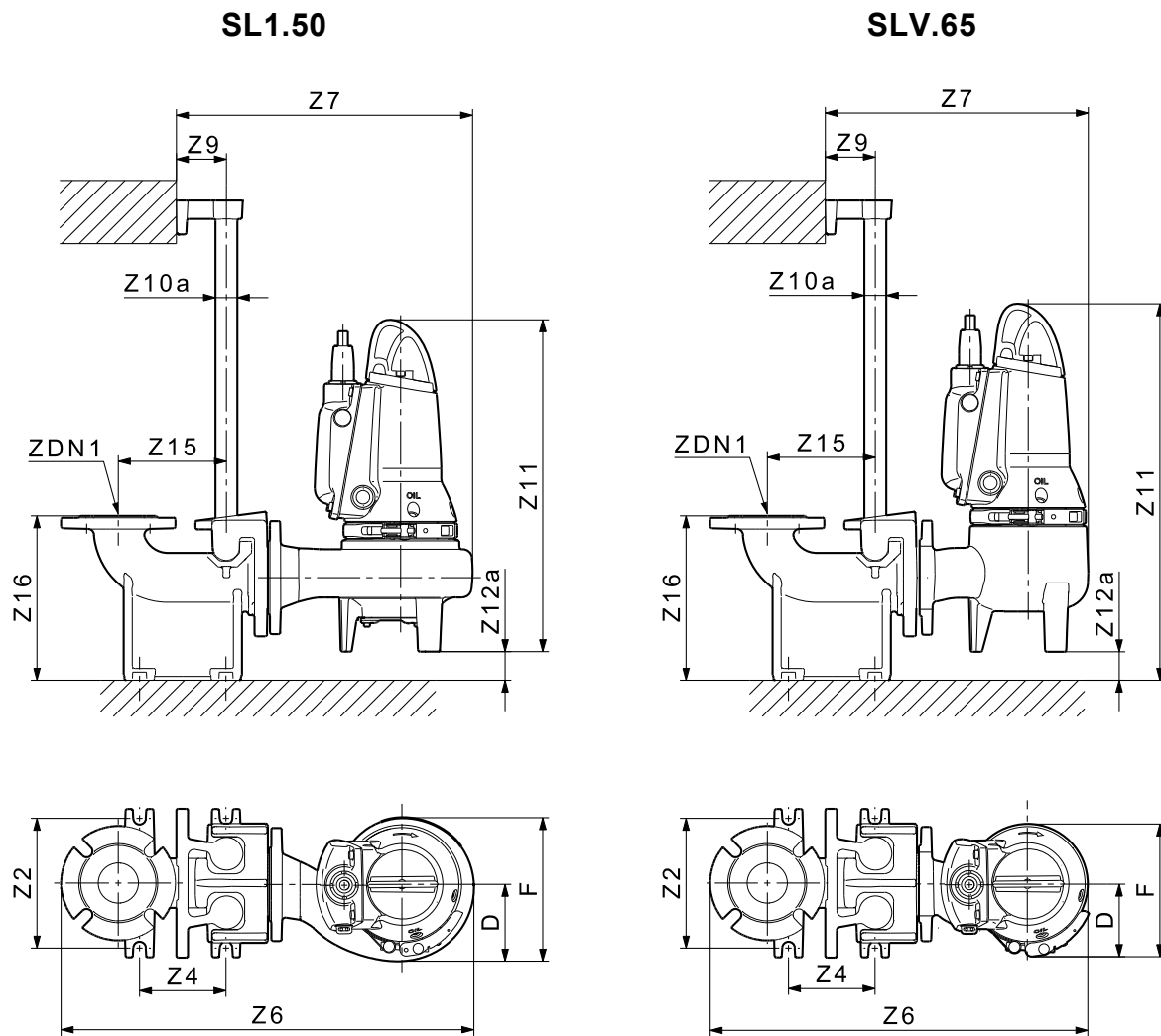

TM04 4797 1310

Fig. 46 One-pump installation on auto-coupling

Pump type	Power [kW]	D	F	Z2	Z4	Z6	Z7	Z9	Z10a	Z11	Z12a	Z15	Z16	ZDN1
SL1	0.9, 1.1 and 1.5	126	236	210	140	661	474	81	1 1/2"	588	43	175	266	DN 65
SLV	0.9, 1.1 and 1.5	119	216	210	140	598	412	81	1 1/2"	610	45	175	266	DN 65

Dimensions

SL1, SLV, DP, EF pumps

SL1.50, SLV.65

SL1.50

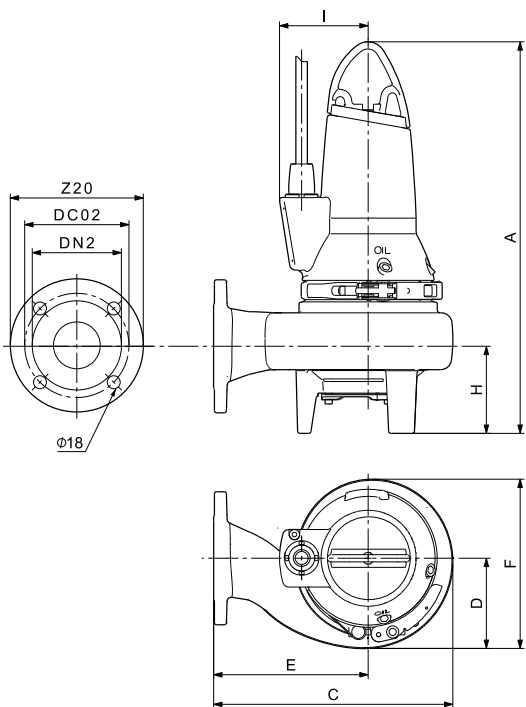

Fig. 47 Free-standing installation

SLV.65

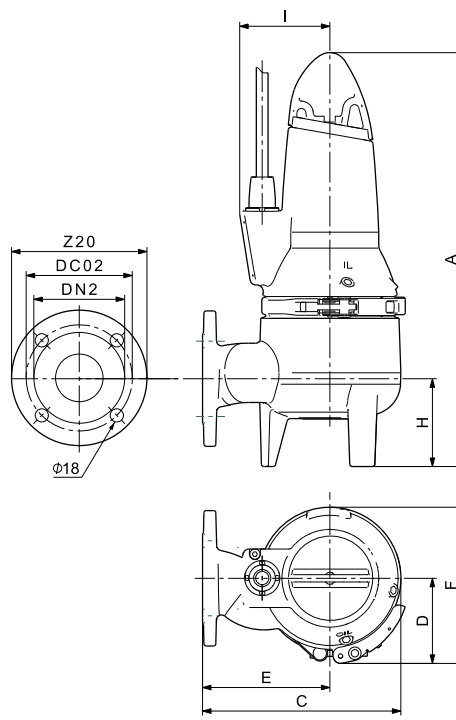
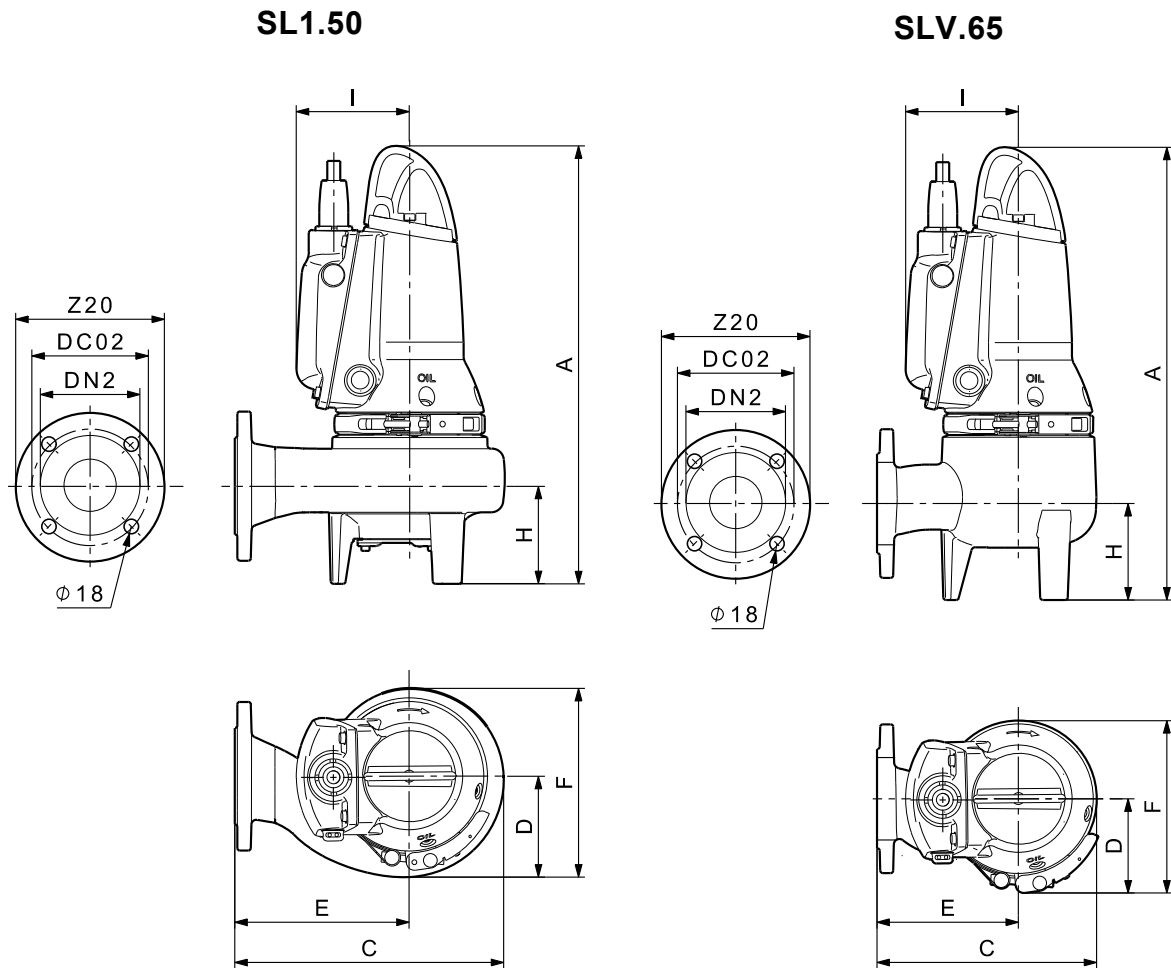

Fig. 48 Free-standing installation

Pump type	Power [kW]	A	C	D	E	F	H	I	DC02	Z20	DN2
SL1	0.6, 0.9, 1.1 and 1.5	544	333	126	217	242	121	123	145	185	DN 65
SLV	0.6, 0.9, 1.1 and 1.5	565	271	97	176	213	120	123	145	185	DN 65

SL1.50 AUTO_{ADAPT}, SLV.65 AUTO_{ADAPT}





TM04 4798 1310



Fig. 49 Free-standing installation

Pump type	Power [kW]	A	C	D	E	F	H	I	DC02	Z20	DN2
SL1	0.6, 0.9, 1.1 and 1.5	544	333	126	217	242	121	123	143	185	DN 65
SLV	0.6, 0.9, 1.1 and 1.5	565	271	97	176	213	120	123	143	185	DN 65

Installation systems

No	Product	Description	Dimensions	SL 1.50.65	SLV.65.65	DP10.50	DP10.65	EF30.50	Product number
1		TM04 6632 0910 Complete auto-coupling system, including guide claw, base plate and upper guide rail holder. Cast iron, epoxy-coated.	Rp 2			•		•	96429519
			DN 65	•	•		•		96090992
2		TM04 4490 1409 Complete auto-coupling system, including guide claw, base plate and upper guide rail holder. Cast iron, epoxy-coated.	DN 80 / DN 65	•	•		•		96102238
3		TM04 6053 4809 Hook-up auto-coupling.	2"			•		•	96004445

Other accessories

No	Product	Description	Dimensions [m]	SL 1.50.65	SLV.65.65	DP10.50	DP10.65	EF30.50	Product number		
4		TM01 7173 1409 Galvanised-steel lifting chain with lifting link and safety hook. With certificates.	4	•	•	•	•	•	96735550		
			6	•	•	•	•	•	96735553		
			8	•	•	•	•	•	96735554		
			10	•	•	•	•	•	96735556		
			12	•	•	•	•	•	96735557		
			4	TM01 7173 1409 Stainless-steel lifting chain with lifting link and safety hook. With certificates.	4	•	•	•	•	•	96735559
					6	•	•	•	•	•	96735564
					8	•	•	•	•	•	96735566
					10	•	•	•	•	•	96735567
					12	•	•	•	•	•	96735569
			5		TM04 7452 2010 Grundfos Powerline PC Tool Link USB communication unit .			All AUTO _{ADAPT} pumps			97655366

DP, EF, SL1 and SLV pumps

Level controllers

Grundfos offers a wide range of pump controllers to keep a watchful eye on liquid levels in the wastewater collecting tank, ensuring correct operation and protection of the pumps.

Controller ranges:

- Dedicated Controls, DC and DCD control cabinets
- LC and LCD level controllers
- CU 100 control box.

The DC, LC and CU 100 are designed for one-pump installations, and the DCD and LCD are designed for two-pump installations.

Dedicated Controls

Grundfos Dedicated Controls is a control system that can control and monitor one or two Grundfos wastewater pumps and a mixer or a flush valve.

Dedicated Controls is used in installations requiring advanced control and data communication.

Main components of the Dedicated Controls system:

- CU 361 control unit
- IO 351B module (general I/O module).

Dedicated Controls is available either as separate components or as control cabinets, i.e. DC and DCD.

The control system can be operated by the following:

- float switches
- a level sensor
- a level sensor and safety float switches.

The control cabinet is available for the following pump sizes and starting methods:

- pumps up to and including 9 kW, direct-on-line starting
- pumps up to and including 30 kW, star-delta starting
- pumps up to and including 30 kW, soft starter.

The separate control unit and modules can be built for practically any size of system.



GrA6270

Fig. 50 Dedicated Controls control cabinet

The DC and DCD control cabinets can be fitted with various units:

- The CU 361 control unit, which is the 'brain' of the Dedicated Controls system, is fitted in the cabinet front. The CU 361 can be fitted with one of the Grundfos CIM communication modules mentioned below, depending on the monitoring needs or the SCADA system:
 - The CIM 200 is a communication module used for the Modbus RTU fieldbus protocol.
 - The CIM 250 is a communication module used for GSM/GPRS communication. The CIM 250 establishes communication between the CU 361 and a SCADA system, thereby allowing the application to be monitored and controlled remotely. This module also offers SMS messaging, for example status and alarm messages.
 - The CIM 270 is a communication module for the Grundfos Remote Management system (GRM). The CIM 270 establishes communication between the CU 361 and the GRM, thereby allowing the application to be monitored and controlled remotely.
- The IO 351B module, which is a general I/O module. The IO 351B communicates with the CU 361 via GENibus.
- The MP 204 motor protector (optional), which provides many electrical status values, for example voltage, current, power, insulation resistance and energy. The MP 204 offers better protection of the pumps than a conventional motor protection device.
- The CUE/VFD (optional), which is either a Grundfos variable-frequency converter or a general variable-frequency converter, also offers better pump protection and a more steady flow through the pit pipes, so the pumps are treated well and the energy consumption is kept at a minimum.

For further information, see the data booklet or installation and operating instructions for Dedicated Controls on www.Grundfos.com (WebCAPS).

LC and LCD

The Grundfos LC and LCD ranges of level controllers comprise three series with a total of six variants:

- LC and LCD 107 operated by air bells
- LC and LCD 108 operated by float switches
- LC and LCD 110 operated by electrodes.

All controllers are ideally suited for applications requiring up to 11 kW motors for direct-on-line starting. The LC and LCD can also be supplied with an integrated star-delta starter for applications requiring larger motors up to and including 30 kW.

Features and benefits

- Control of one pump (LC) or two pumps (LCD).
- Automatic alternating operation of two pumps (LCD).
- Automatic test run (prevents shaft seals from becoming jammed in the event of long periods of inactivity).
- Water hammer protection.
- Starting delay after power supply failure.
- Automatic alarm resetting, if required.
- Automatic restarting, if required.
- Alarm outputs as NO and NC.



TM04 2360 2408

Fig. 51 LCD 110 for two-pump installations

When an SMS module (optional) is fitted in an LC or LCD controller, it acts as a time recorder for the pumps, and when programmed (using an ordinary mobile phone with text messaging facility), it can send text messages containing "high-level alarm", "general alarm", information about operation and the number of times the pump has started. The SMS module is also available with battery and can thus send text messages that will inform you of power failure and when the power has been restored.

For further information, see the data booklet or installation and operating instructions for the LC and LCD controllers on www.Grundfos.com (WebCAPS).

CU 100

The CU 100 control box is designed for the starting, operation and protection of small wastewater pumps.

The control box is available in several variants which can be used for the following:

- single-phase pumps (up to and including 9 A)
 - three-phase pumps (up to and including 5 A)
- and
- start/stop by means of a float switch
 - manual start/stop.

During manual operation, the pump is started and stopped with the on/off switch.

During automatic operation, the float switch will start and stop the pump.

For further information, see the installation and operating instructions for the CU 100 on www.Grundfos.com (WebCAPS).



TM02 6459 0703

Fig. 52 CU 100

DP, EF, SL1 and SLV AUTO_{ADAPT} pumps

Grundfos CIU unit

The Grundfos CIU unit (CIU = Communication Interface Unit) is used as a communication interface between a Grundfos product and a main network.

The CIU unit is used as an interface for following:

- Configuration of pump parameters required for water level control.
- Online monitoring of pit and pump values.
- Manual water level control (forced start/stop).
- Obtaining of measured and logged data that is valuable for pump service and pit optimisation.

The CIU unit is designed for use together with Grundfos DP, EF, SL1 and SLV AUTO_{ADAPT} pumps.

Communication can be established with the Grundfos R100 remote control or by using the main network interface of the CIU unit.

Available CIU units:

- CIU 902 unit (without CIM module)
- CIU 202 Modbus unit
- CIU 252 GSM/GPRS unit
- CIU 272 GRM unit (Grundfos Remote Management).

The CIU unit incorporates one or two modules:

- Multi-purpose IO module with I/O functionality, IR communication interface and powerline communication.
- CIM 2XX module (optional).

For further information about the CIM module fitted, see installation and operating instructions for the relevant CIM module.

If a CIM module is fitted in the CIU unit, the sensors connected to the digital input of the IO module can be remotely monitored from a centrally located SCADA system.

Grundfos R100 remote control

The Grundfos R100 remote control is designed for wireless IR communication with Grundfos products.

The R100 can communicate with the DP, EF, SL1 and SLV AUTO_{ADAPT} pumps via a CIU unit.

The R100 is to be regarded as an ordinary service and measuring tool and is therefore designed to withstand wear and stress from everyday use.

Name	DC	DCD	LC	LCD	CU 100	AUTO _{ADAPT}	CIU
Application							
One pump	•	•	•	•	•	•	•
Two pumps		•		•		•	•
Mixer	•	•					
Battery back-up	•	•					
Level sensor							
Float switches	•	•	•	•	•		• ⁷⁾
Electrodes			•	•			• ⁷⁾
Air bells			•	•			• ⁷⁾
Pressure sensor	•	•				• ³⁾	• ⁷⁾
Ultrasonic sensor	•	•					• ⁷⁾
Analog level sensor with safety float switches	•	•					• ⁷⁾
Starting method							
Direct-on-line starting (DOL)	•	•	•	•	•	•	•
Star-delta starting	•	•	•	•			
Soft starter	•	•					
Basic functions							
Start and stop of pump(s)	•	•	•	•	•	•	•
Pump alternation		•		•		•	•
High-level alarm	•	•	•	•		•	•
Dry-running level alarm	•	•	•	•		•	•
Flow measurement (calculated or via flow sensor)	•	•					
Pump statistics	•	•				• ⁴⁾	•
Conflicting levels alarm	•	•					
Advanced functions							
Start and stop delays	•	•	•	•		•	•
Motor temperature sensor	•	•	•	•		• ⁴⁾	•
Test run/anti-seizing	•	•	•	•		•	•
Daily emptying (emptying the pit once a day)	•	•					•
Water-in-oil sensor input	•	•					
Communication							
SMS messaging	• ²⁾	• ²⁾	• ¹⁾	• ¹⁾			• ²⁾
SCADA communication (GSM/GPRS)	• ²⁾	• ²⁾					• ⁵⁾
User interface							
Level indication	•	•	•	•			• ⁶⁾
Graphical display	•	•					• ⁶⁾
PC Tool WW Controls	•	•				•	

¹⁾ If an SMS module is fitted.

²⁾ If a CIM 250 GSM/GPRS module is fitted in the CU 361.

³⁾ Built-in pressure sensor and dry-running sensor.

⁴⁾ Built-in, but a Grundfos CIU unit is required to get access to data or setting of parameters.

⁵⁾ Modbus, GSM, GPRS, SMS and GRM options.

⁶⁾ When using a Grundfos R100 remote control.

⁷⁾ Inputs for external sensors (NO or NC).

WebCAPS

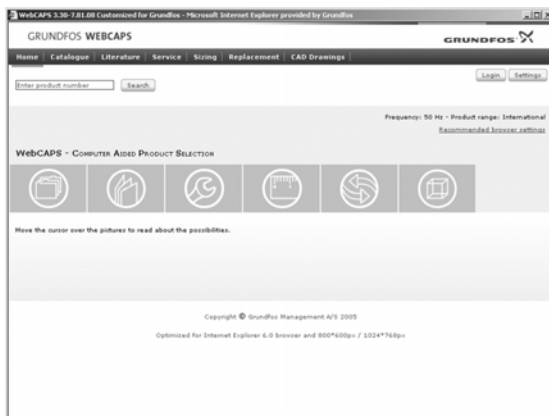

WebCAPS is a **Web-based Computer Aided Product Selection** program available on www.grundfos.com.

WebCAPS contains detailed information on more than 185,000 Grundfos products in more than 20 languages.

In WebCAPS, all information is divided into six sections:

- Catalogue
- Literature
- Service
- Sizing
- Replacement
- CAD drawings.

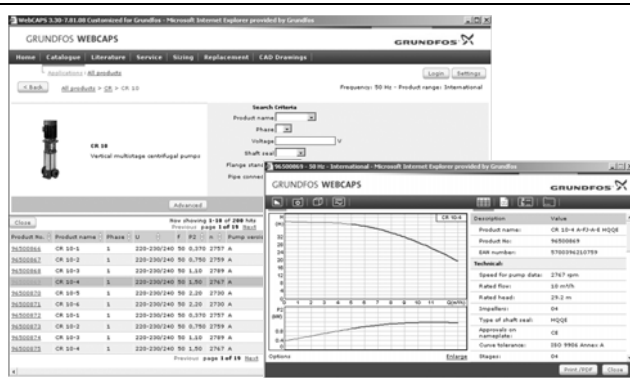

Catalogue

This section is based on fields of application and pump types, and contains

- technical data
- curves (QH, Eta, P1, P2, etc.) which can be adapted to the density and viscosity of the pumped liquid and show the number of pumps in operation
- product photos
- dimensional drawings
- wiring diagrams
- quotation texts, etc.

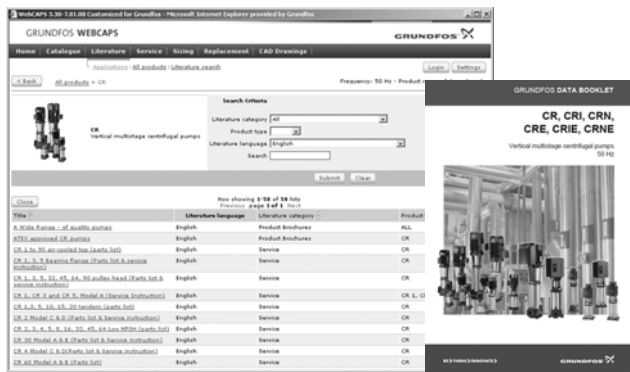

Literature

In this section you can access all the latest documents of a given pump, such as

- data booklets
- installation and operating instructions
- service documentation, such as Service kit catalogue and Service kit instructions
- quick guides
- product brochures.

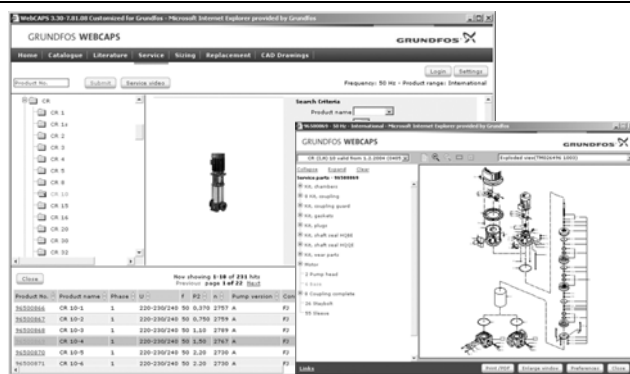

Service

This section contains an easy-to-use interactive service catalogue. Here you can find and identify service parts of both existing and discontinued Grundfos pumps.

Furthermore, this section contains service videos showing you how to replace service parts.

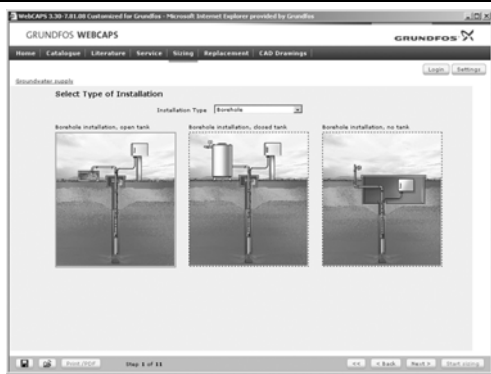

Sizing

This section is based on different fields of application and installation examples, and gives easy step-by-step instructions in how to

- select the most suitable and efficient pump for your installation
- carry out advanced calculations based on energy consumption, payback periods, load profiles, life cycle costs, etc.
- analyse your selected pump via the built-in life cycle cost tool
- determine the flow velocity in wastewater applications, etc.



Replacement

In this section you find a guide to selecting and comparing replacement data of an installed pump in order to replace the pump with a more efficient Grundfos pump. The section contains replacement data of a wide range of pumps produced by other manufacturers than Grundfos.

Based on an easy step-by-step guide, you can compare Grundfos pumps with the one you have installed on your site. When you have specified the installed pump, the guide will suggest a number of Grundfos pumps which can improve both comfort and efficiency.

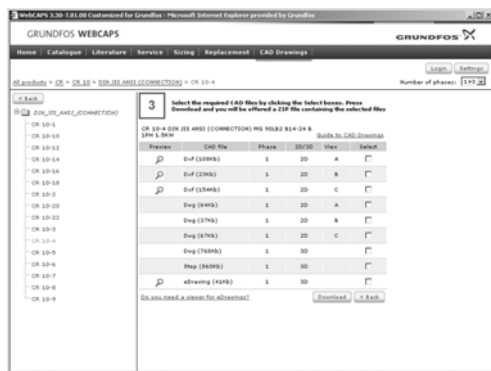

CAD drawings

In this section it is possible to download two-dimensional (2D) and three-dimensional (3D) CAD drawings of most Grundfos pumps.

These formats are available in WebCAPS:

- 2-dimensional drawings:
- .dxf, wireframe drawings
 - .dwg, wireframe drawings.
- 3-dimensional drawings:
- .dwg, wireframe drawings (without surfaces)
 - .stp, solid drawings (with surfaces)
 - .eprt, E-drawings.

WinCAPS



Fig. 53 WinCAPS CD-ROM

WinCAPS is a **Windows-based Computer Aided Product Selection** program containing detailed information on more than 185,000 Grundfos products in more than 20 languages.

The program contains the same features and functions as WebCAPS, but is an ideal solution if no Internet connection is available.

WinCAPS is available on CD-ROM and updated once a year.

Subject to alterations.

97655139 0710
Repl. 97655139 0510

GB

ECM: 1063197

The name Grundfos, the Grundfos logo, and the payoff Be-Think-Innovate are registered trademarks owned by Grundfos Management A/S or Grundfos A/S, Denmark. All rights reserved worldwide.